

Do you see what I see? - Understanding the challenges of colour-blindness in online learning

Colin Egan, Amanda Jefferies, Edmund Dipple and David Smith
School of Computer Science, University of Hertfordshire, Hatfield UK.

c.egan@herts.ac.uk

a.l.jefferies@herts.ac.uk

Abstract

In this paper we introduce the 'Hertfordshire Colour-blind Emulator' (HCBE) software application. Currently, our aim is to raise awareness of the challenges that the colour-blind encounter on their learning journey. HCBE emulates four major types of colour-blindness: protanopia, deuteranopia, tritanopia and monochromacy. HCBE accepts an image file and outputs that image in the way that a colour-blind learner would see the original inputted image. For any inputted images there are four options for outputted images, one for each colour-blind type.

Colour-blindness is often considered to be a mild disability where, on the whole, a colour-blind learner has developed his/her own "coping mechanisms" to avoid, but not to eliminate, problems in their learning. The problems faced by some colour-blind users of online games have recently been highlighted in the research, this paper identifies some of the issues for students in their learning. The Equality Act 2010 places the responsibility of making reasonable adjustments to aid the disabled on the educational practitioner by providing legal rights for disabled people, irrespective of the severity of the disability.

We show that colour-blind learners do have problems interpreting information when that information is presented as images. In particular with increasing reliance on using VLEs (Virtual Learning Environments) as a repository for study materials then it is possible that the challenges which colour-blind users suffer will be exacerbated. Estimates of the frequency of colour-blindness show that there are approximately 8% males and about 0.4% females who are colour-blind. It is also our experience that few practitioners are aware of the problems that colour-blindness can cause and even fewer practitioners that make any reasonable adjustment as required by the UK's Equality Act 2010.

Keywords

colour-blind, e-learning, online learning, disability, accessibility, Equality Act 2010

1. Introduction

Approximately 8% of males and 0.4% of females in the adult population are typically affected by colour-blindness (BUPA, 2011). In Further and Higher Education where class sizes of 200 (and larger) are not unusual, this means that in a class size of about 200 learners there could be up to 16 colour-blind male learners and maybe 1 female learner. As educational practitioners we are typically using VLEs (Virtual Learning Environments) more and more in the daily delivery of our teaching materials. Students who suffer from the various forms of colour-blindness may experience problems when using computers, for example the use of a VLE may cause a colour-blind learner difficulties with reading text and viewing or interpreting images (including graphs). The focus of this study is to improve the learning experiences of colour-blind learners.

Colour-blindness is normally hereditary and includes a range of conditions where those conditions are characterised by an inability to see certain colours in the normal spectrum, currently there is no known cure. There are four major types of colour-blindness: protanopia, deuteranopia, tritanopia and monochromacy. Most people are aware of the red-green issues for colour-blind users, but this is only a more common form of the spectrum of effects. It is generally considered to be a mild disability. However, in the UK, the Equality Act (2010) (which replaces the Disability Discrimination Acts (1995) and (2005) provides legal rights for all disabled people irrespective of the severity of the disability. As educational practitioners it is now our responsibility to comply with the Equality Act 2010 and to provide reasonable adjustments to our educational materials so that colour-blind learners can be provided with the same opportunity to learn as those who not colour-blind.

In this paper, we introduce the use of a colour-blind software emulator, the Hertfordshire Colour-blind Emulator (HCBE) which displays coloured images in the same way that colour-blind users would see them. The aim of HCBE is to raise awareness of some of the problems that the colour-blind encounter on their learning journey and to identify how we as practitioners can help such learners by improving their educational journey. The software allows the passing of an image into the HCBE application and then the HCBE outputs coloured images which indicate how a colour-blind learner would see the same image. We then ask the practitioner a simple question “Do the new images convey the same message to a colour-blind learner as it would to non colour-blind learners?” Where the answer is yes, then the practitioner does not need to make any changes as the requirements of the learner and the Equality Act have both been satisfied. In the alternate case, then the image should be amended to make reasonable adjustment to the needs of the colour-blind learner and to comply with the Equality Act. The solution may in fact be to redesign the image with a simple separation of colours or to effect a simple change of colour schema. Recent research into online gaming has already highlighted the problems that colour-blind gamers have in differentiating quickly enough between for example friends and foes in some of the more popular wargames (BBC, 2011)

2. Colour-blindness

Colour-blindness has been defined as “a range of conditions that are characterised by an inability to see certain colours” (BUPA, 2011). However, colour-blindness can be manifested in many different ways but there is four most prominent types, which we consider in our study, protanopia, deuteranopia, tritanopia and monochromacy. To understand how colour-blindness affects how a person perceives colour, it is important to understand the biology of how the human eye normally perceives colour. A human retina is comprised of rod and cone cells. Rod cells become active in low light conditions, and determine the brightness of the image that the brain receives. It is the cone cells that are affected by colour blindness. The “normal” eye contains 3 variants of cone cells: L, M and S. The L-cone detects long wavelength light (yellow-red), the M-cone detects medium wavelengths (green) and the S-cone detect short wavelength light (Blue) (de Paula,2006)). The human brain will determine the colour of an image based on the ratio between the signals from L, M and S. Colour-blindness occurs when one or more of these cone cells types are either damaged or absent (colour-blindness.com, 2011).

The outcome of personal discussions with a number of colour-blind learners has revealed that many learners have developed their own “coping mechanisms” over their learning journey from the early days of their schooling. “Coping mechanism” may help to reduce the impact of their disability, but it must be emphasised that such they only reduce and do not eliminate the problems of teaching to the colour-blind learners. It also highlights that, on the whole, practitioners are not currently making reasonable adjustments with their teaching material to cater for colour-blind learners.

2.1 Protanopia

Protanopia is manifested as red-green colour-blindness, which is caused by a complete lack of retinal photoreceptor cells. It has been estimated that approximately 1% of males are affected by this condition (Cassin, 1990). Figures 1 a) and b), show a pie-chart that compares normal vision with protanopian colour-blindness.

Figure 1b) shows a distinct difference to Figure 1a), where for example in red in Figure 1a) appears as black in Figure 1b), orange in Figure 1a) appears as a green hue in Figure 1b) and so on. If this pie-chart had been presented as educational material then it is clear that the protanopian colour-blind person would have difficulty interpreting the data. Furthermore, if the orange and green in Figure 1a) had been aligned adjacently then the protanopic colour-blind learner would not have been able to make any differentiation between the two colours. This can also be seen with the blue, and violet of Figure 1a) and also the indigo and red of Figure 1a). On close examination it can be seen that the red and green are indistinguishable, and in this example the effect seems to spill over to encompassing yellow as well.

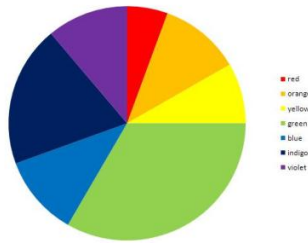

Figure 1a) normal vision

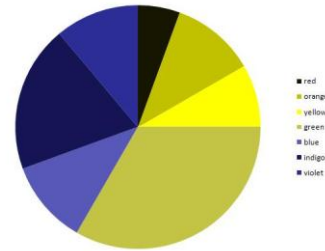

Figure 1b) protanopia

2.2 Deuteranopia

Deuteranopia is similar to protoanopia, in that red and green are almost indistinguishable. However, the cause of the condition is slightly different, in that it is the green receptors in the eye that are missing [6]. For all intents and purposes the effect is the same as protanopia, although the contrast between blue and purple seems to be affected to a greater degree by deuteranopia. Figure 2a) is the same pie-chart as Figure 1a), but Figure 2b) is the same pie-chart but it represents deuteranopia.

Similarly to Figures 1a) and b) Figure 2a) shows a distinct difference from Figure 2b). Following the same example, red in Figure 2a) appears as black in Figure 2b), the orange in Figure 2a) appears as a green hue in Figure 2b) and so on. As with Figure 1, if this pie-chart had been presented as educational material then it is clear that the deuteranopic colour-blind person would have difficulty interpreting the data.

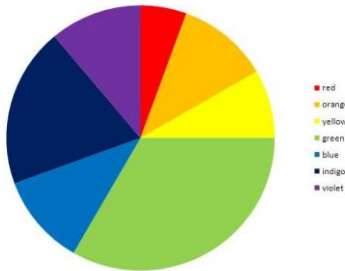

Figure 2a) normal vision

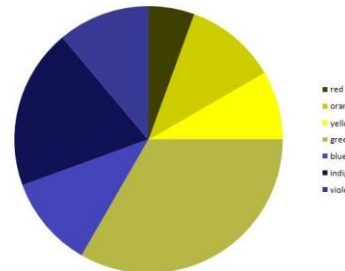

Figure 2b) deuteranopia

Furthermore if the orange and green in Figure 2a) had been aligned adjacently then the deuteranopic colour-blind learner would not have been able to make any differentiation between the two colours. This can also be seen with the blue, and violet of Figure 2a) and also the indigo and red of Figure 2a). Again, on close examination it can be seen that that for the colour-blind learners red and green are indistinguishable.

2.3 Tritanopia

Tritanopia colour-blindness is manifested with a blue-yellow variation due to the lack of blue photoreceptors. It is not present as frequently as protanopia and deuteranopia [6]. As seen above, Figure 3a) is the same pie-chart as Figures 1a) and Figure 2a), but Figure 3b) shows the same coloured pie-chart as those suffering from tritanopia would see it.

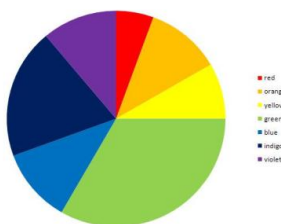

Figure 3a) normal vision

Figure 3b) tritanopia

There are clear differences between normal vision, protanopia vision, deuteranopia vision and tritanopia vision. Those suffering from tritanopia can distinguish red as shown in Figure 3a) and 3b), whereas those suffering from protanopia or deuteranopia cannot. However, there are distinct differences between orange, yellow, green, blue, indigo and violet. On close observation of Figure 3a) and Figure 3b) it can be seen that blue and green are hard to distinguish, as are purple and red/orange. Again, as with protanopia and deuteranopia, if this pie-chart had been presented to a tritanopia colour-blind person there would have been great difficulty in interpreting the presented data.

2.3 Monochromacy

Monochromacy is the complete loss of colour, where colours are visible as shades of grey. Monochromacy is frequently termed as “total colour-blindness” (Color-blindness.com,2010). Monochromacy is caused by either defected cones or absence of cones. As discussed above, Figure 4a) is the same pie-chart as Figure 1a), Figure 2a) and Figure 3a), but Figure 4b) shows the same pie-chart for those suffering from monochromacy.



Figure 4a) normal vision

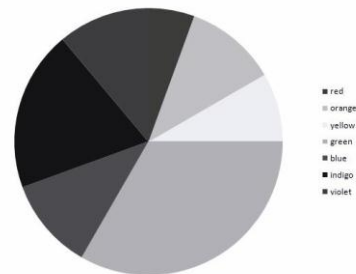

Figure 4b) monochromacy

Comparing normal vision with monochromacy vision clearly shows distinct differences to all of the other variants of colour-blindness. In this case red, orange and green are indistinguishable as are blue and violet. Only indigo appears distinguishable, but as black. Such a pie-chart would cause a monochromatic learner a great deal of difficulty interpreting the data.

3 Emulating Colour-blindness and HCBE

In this section we discuss how the academic with no colour loss can experience the same view as the colour-blind user. The simplest method of simulating colour-blindness is by offsetting colours. For example, in the case of deuteranopia (red-green colour-blindness), in a standard RGB (red/green/blue) colour value, the red part of the colour could be reduced to 0. However, this method should not be taken as an accurate portrayal of what a colour-blind person actually sees, since the cones in the human eye do not map directly to the 3 components of an RGB value. As such, this method is not a proper representation of colour-blindness.

Alternatively, direct colour mapping can be used where a palette of colours can be referenced directly against an identically sized palette. However, careful mappings are required to ensure that there are no errors. A different palette is required for each type of colour-blindness.

A better method is to use linear algorithms where the resultant colour change is computed. Ideally the result of using direct colour mapping and the usage of linear algorithms should be identical. The colour values perceived by the eye are mapped out by the LMS (long/medium/short) photoreceptor

activations in the visible spectrum, but these photoreceptor cells do not directly correspond to standard RGB values. Capilla et al (2004) produced a conversion matrix that converts an RGB value into an LMS value. In HCBE, we use a matrix based on Capilla's idea where one of the cone values is modified, depending on which type of colour-blindness is being emulated. Afterwards, HCBE converts the LMS value back into an RGB value, as shown in Figure 5. The resultant RGB is then outputted.

$$\begin{pmatrix} L \\ M \\ S \end{pmatrix} = (RGB_to_LMS) \begin{pmatrix} R \\ G \\ B \end{pmatrix}$$

$$\Rightarrow \begin{pmatrix} L \\ M \\ S \end{pmatrix} = \begin{pmatrix} 17.8824 & 43.5161 & 4.11935 \\ 3.45565 & 27.1554 & 3.86714 \\ 0.0299566 & 0.184309 & 1.46709 \end{pmatrix} \begin{pmatrix} R \\ G \\ B \end{pmatrix}$$

$L = 17.8824R + 43.5161G + 4.11935B$
$M = 3.45565R + 27.1554G + 3.86714B$
$S = 0.0299566R + 0.184309G + 1.46709B$

Figure 5 HCBE's matrix algorithm for RGB conversion to LMS and then LMS conversion back to RGB

In order to simulate damaged cones or lack of cones, the exact values of all three cones must be obtained. This can be achieved by using a transformation matrix, such as that proposed by Viénot et al, (1999) as shown in Figure 6. Viénot's transformation matrix can also be shown as a linear equation.

$$\begin{pmatrix} L \\ M \\ S \end{pmatrix} = (RGB_to_LMS) \begin{pmatrix} R \\ G \\ B \end{pmatrix}$$

$$\Rightarrow \begin{pmatrix} L \\ M \\ S \end{pmatrix} = \begin{pmatrix} 17.8824 & 43.5161 & 4.11935 \\ 3.45565 & 27.1554 & 3.86714 \\ 0.0299566 & 0.184309 & 1.46709 \end{pmatrix} \begin{pmatrix} R \\ G \\ B \end{pmatrix}$$

$L = 17.8824R + 43.5161G + 4.11935B$
$M = 3.45565R + 27.1554G + 3.86714B$
$S = 0.0299566R + 0.184309G + 1.46709B$

Figure 6 HCBE's (Viénot's) transformation matrix algorithm for conversion of RGB to LMS

After modification of either the L, M or S photoreceptor cell value, which depends on the type of colour

blindness, the LMS colour value must then be converted back into RGB to be recognised on the output display. This is achieved by using the inverse matrix as shown in Figure 7.

To emulate Protoanopia, the L photoreceptor cell values require modification. To emulate Deuteranopia the M photoreceptor cell value requires modification and to emulate Tritanopia S photoreceptor cell value requires modification.

$$\begin{pmatrix} R \\ G \\ B \end{pmatrix} = (RGB_to_LMS)^{-1} \begin{pmatrix} L \\ M \\ S \end{pmatrix}$$

$$\begin{pmatrix} R \\ G \\ B \end{pmatrix} = \begin{pmatrix} 0.080944 & -0.130504 & 0.116721 \\ -0.0102485 & 0.0540194 & -0.113615 \\ -0.000365294 & -0.00412163 & 0.693513 \end{pmatrix} \begin{pmatrix} L \\ M \\ S \end{pmatrix}$$

$R = 0.080944L - 0.130504M + 0.116721S$ $G = -0.0102485L + 0.0540194M - 0.113615S$ $B = -0.000365294L - 0.00412163 + 0.693513S$

Figure 7 HCBE's reverse transformation matrix algorithm for conversion of LMS to RGB

4. Teaching with HCBE

In this section we present an example of the use of a circuit diagram and how this may be seen by different types of colour-blind users. Figures 8a) 8b) 8c) 8d) and 8e) show a typical circuit block diagram example used in the teaching of Computer Engineering. The diagram has been generated in LogicWorks (2010), which is a commonly used interactive tool for the teaching and learning of digital logic. For this study, it is not necessary to have any knowledge or understanding of Computer Engineering. In this circuit diagram (Quick, 2010) the input signal is obtained from the left hand side with 1 being an asserted signal and 0 being a de-asserted signal. In this example, both input signals are asserted as 1 in the boxes. The signals are then transmitted along the (normal vision) red lines and they then become inputs into various digital logic components (actual details of these components are not necessary for this study). The output signals are generated and reflected in the boxes on the right hand side. In this example, all of the output signals are de-asserted and are shown in the boxes as 0.

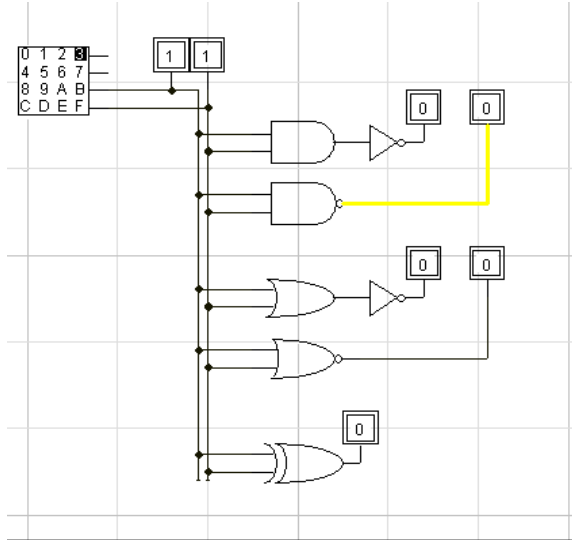
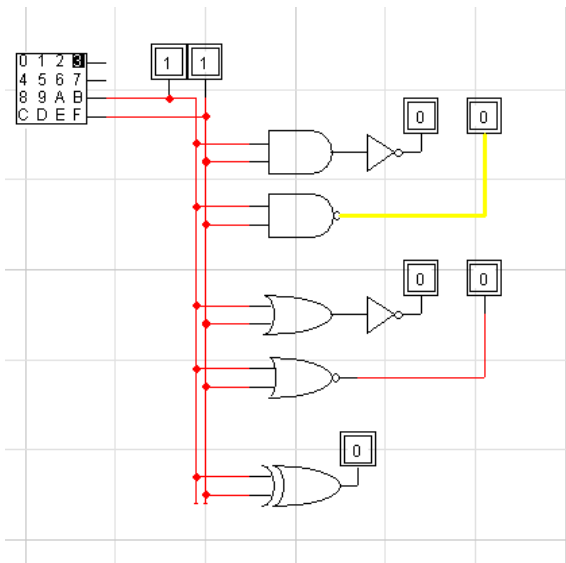
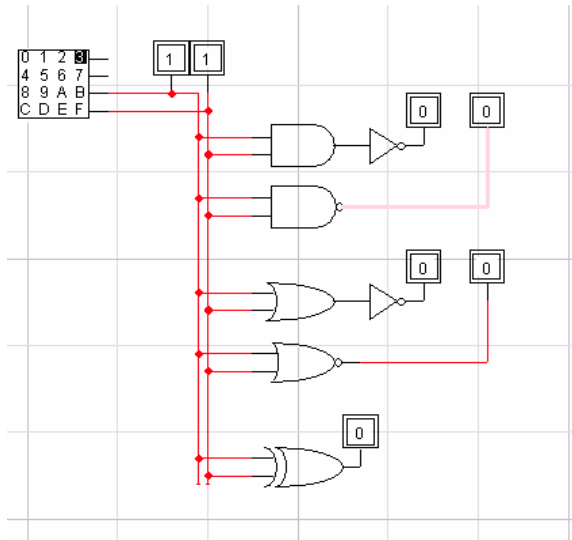
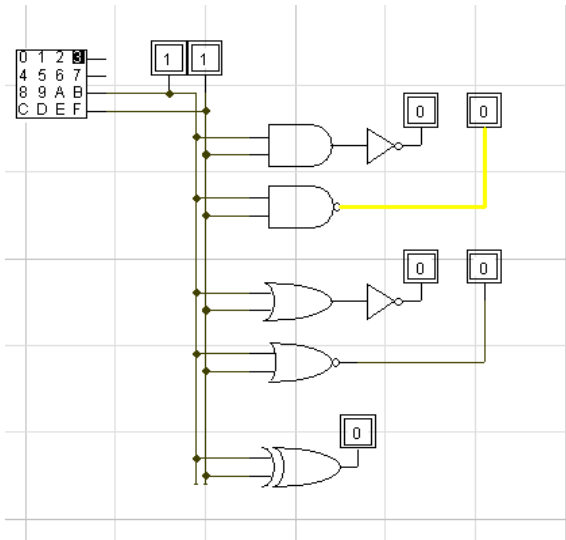
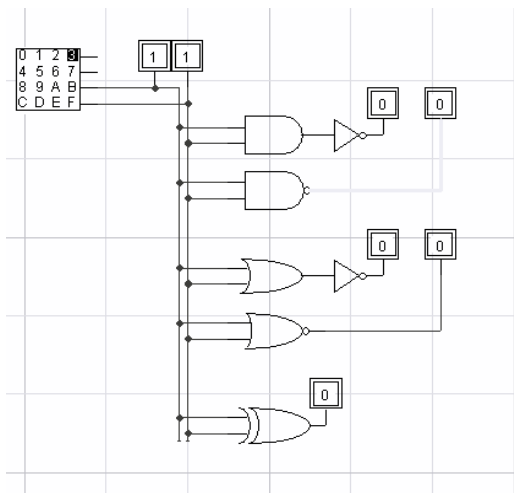

Figure 8a): Normal vision LogicWorks circuit diagram 8b): Protanopia LogicWorks circuit diagram



8c): Deuteranopia LogicWorks circuit diagram

8d): Tritanopia LogicWorks circuit diagram



8e): Monochromacy LogicWorks circuit diagram

By comparison of all the circuit diagrams in 8b), 8c) and 8d), it is evident that colour-blind learners would have difficulty in interpreting this circuit diagram. For example, comparing Figure 8a) with Figure 8b) a learner suffering from protanopia, would not be able to see the input signals as they appear black and grey. Also, there would be difficulty in seeing at least one of the output signals. Also, comparing Figure 8a) with Figure 8b) a learner suffering from deuteranopia would have similar problems. Now by comparing Figure 8a) with Figure 8c) a learner suffering from tritanopia would be able to see the input signals but would have difficulty with the output signals. Finally, comparing Figure 8a) with Figure 8d) a learner suffering from monochromacy would be unable to detect both input and output signals. Furthermore, the LogicWorks background grid-lines can also make the circuit diagram difficult to be viewed by a colour-blind learner.

5. Some example solutions

The Equality Act 2010 clearly indicates that the responsibility of making reasonable adjustments lies with the practitioner, and yet in reality few (if any) adjustments are typically being made to help colour-blind learners. Once awareness has been raised there are some quick and simple solutions to enhance the learning experience of the colour-blind. From the pie-charts shown as Figures 1 – 4, a simple separation of individual colours, which may appear merged for a colour-blind learner, may be sufficient to potentially solve the problem. Alternatively, the use of shading such as stripes and/or dashes may be a potential solution. In other cases such as the circuit diagram shown as Figure 8, the use of thicker/thinner lines, dashed lines or bolding lines may potentially solve the problem. We consider that with thought and creativity the practitioner should be able to improve the learning experience of a colour-blind learner without impacting on the experiences of the non colour-blind user.

4 Discussion and plans for further work

From this study we conclude that colour-blind learners do have considerable difficulties in interpreting what those without colour-blindness see as simple and/or detailed information and this has been borne out by *inter alia* recent research into colour-blind gamers. From our discussions with colour-blind users they have raised particular areas where their learning has suffered, with one older user recalling being dismissed from her school chemistry class because she said that a 'solution was the wrong colour.' Frequent anecdotes from other users relayed to the research team have recalled problems with coloured wiring, as depicted in the example from the teaching of circuit diagrams given above.

Currently, many colour-blind learners develop their own method(s) to overcome their disability. Even though colour-blindness is considered to be a mild disability, the Equality Act 2010 clearly places the responsibility of reasonable adjustments onto the practitioner. In our experience, currently reasonable adjustments are rarely made to aid the colour-blind learner. In this paper, we have raised awareness of the detrimental impact that teaching materials can have on the colour-blind learners. We have also emphasised that the responsibility of making reasonable adjustments lies with the practitioner and not with the learner. Furthermore, we have shown that reasonable adjustments can be made with some consideration and deliberation of the teaching material.

HCBE is in the early stages of development and implementation. Currently HCBE only return images in the way that a colour-blind learner would see the original inputted image. We, therefore, propose to enhance HCBE to provide example potential solutions to aid the practitioner to make the necessary reasonable adjustments of their teaching material for the colour-blind learners. Consequently, the practitioner should be able to enhance the learning experience of the colour-blind learners and comply with the Equality Act. However, HCBE creating potential solutions will be a non-trivial task. This is because the solutions HCBE will provide will be generic potential solutions to specific and detailed teaching material. As HCBE is a software tool, it will have no knowledge or any understanding of the teaching material. Hence, the ultimate responsibility continues to remain with the practitioner and HCBE's solutions will serve to identify the problem and support the decision-making of future suggestions for improving practice.

Acknowledgements

The authors acknowledge with gratitude the support of the University of Hertfordshire's Proof of Concept fund for their provision of a generous funding grant to support the HCBE research. We are also grateful to all those users who have shared their experiences freely to help us understand more about the difficulties colour-blind users may have with online learning materials.

References

- BBC, (2011) <http://www.bbc.co.uk/news/technology-13054691> (accessed June 16th 2011)
- BUPA. (2008). *Colour blindness*. [Online] (Updated March 2008) Available at: http://hcd2.bupa.co.uk/fact_sheets/html/colour_blindness.html [Accessed 30 May 2011].
- Capilla, P., Luque M J and D´rez-Ajenjo M J., *Looking for the dichromatic version of a colour vision model* Jnl.of Optics A: Pure and Applied Optics. 6, pp. 906 – 919, 2004.
- Cassin, B. and Solomon, S.,(1990.) *Dictionary of Eye Terminology*. Gainesville, Florida: Triad Publishing Company,
- Colour-Blindness.com. (2010). *How Color Blindness Works*. [Online] (Updated 22nd February 2010) Available at: <http://www.colour-blindness.com/general/how-it-works-science/> [Accessed 30 May 2011].
- De Paula J B., *Converting RGB Images to LMS Cone Activations* TR-06-49 The University of Texas, Austin, USA. October 2006.
- Disability Discrimination Act (1995). Available at: <http://www.legislation.gov.uk/ukpga/1995/50/contents> [Accessed 30 May 2011].
- Disability Discrimination Act (2005). Available at <http://www.legislation.gov.uk/ukpga/2005/13/contents> [Accessed 30 May 2011].
- Equality Act (2010). Available at: http://www.equalities.gov.uk/equality_act_2010.aspx [Accessed 30 May 2011].
- LogicWorks, Available at:<http://www.capilano.com/> [Accessed 30 May 2011]
- Quick P., (2010) *Computer Systems Architecture*, Teaching Material for Level 4 BSc Computer Science module 4COM0051. School of Computer Science, University of Hertfordshire. UK. Semester B Academic Year 2010/11
- Viénot F, Brettel H, Mollon J., (1999) *Digital Video Colourmaps for Checking the Legibility of Displays by Dichromats*. Color and Research Application, Vol., Issue 4, pp. 243 – 252, August 1999.