

INTRODUCTION



1.1 Cannabis

The hemp plant *Cannabis sativa* L., (Cannabaceae), native to Central Asia (probably north Afghanistan) has been used for medicinal purposes for millennia across many cultures. The first evidence of its therapeutic properties dates back to a description of the drug in a Chinese compendium of medicines at the time of the Chinese emperor Shen Nung dated 2737 B.C. In the 19th century the drugs were widely prescribed in the Western world for the treatment of cough, fatigue, rheumatism, asthma, delirium tremens, migraine headache, constipation and dysmenorrhea (Grinspoon, 1969).

In addition to its great therapeutic potential, cannabis is known by numerous names such as marijuana, weed, blow, gear, grass and is the most commonly used illicit drugs among recreational substance abusers throughout the world. In many countries statistics quote that more than 50 % of young people have used it at least once (Iversen, 2005).

The possession of cannabis was first banned in 1915, in California. Although cannabis became illegal in the USA, it was in the British pharmacopoeia and was occasionally used until 1971 when its use was outlawed in Misuse of Drugs Act (Baker et al., 2003).

The most probable reason for the abuse is the action of the main psychoactive component of marijuana, (-)- Δ^9 -tetrahydrocannabinol (Δ^9 -THC), on the central nervous system (CNS), affecting cognition, memory and mood.

After long-term cannabis use, mostly at high intake levels there is some evidence about it causing psychosocial harm to the user (lower educational achievement,

psychiatric illnesses- schizophrenia, depression, anxiety) but by comparison with other 'recreational' drugs, cannabis is a relatively safe drug (Iversen, 2005).

In 1997, two referenda in Arizona and California and, later, others in eight additional states were aimed at providing legal status to marijuana cigarettes for medical purposes (Goutopoulos and Makriyannis, 2002). However, social attitudes and political conditions maintain that cannabis is an illegal drug. This fact has deeply influenced the public perception of the role of cannabis as medicine. Many scientific discoveries rekindled interest in the role of cannabinoids (including nonpsychotropic plant and synthetic cannabinoids, as well as cannabis extracts) in therapeutics. More clinical studies are required in order to evaluate the risks and benefits of these applications (Di Marzo and De Petrocellis, 2006; Ware, 2008). Higher caution should be taken in clinical trials of smoked marijuana and they should be limited to short-term use or even excluded as a potential therapy. Several lines of evidence support this statement, including the presence of known carcinogens and co-carcinogens in marijuana smoke, and also results from cellular, tissue animal, and human studies suggesting an association between marijuana smoking and cancer (Kalant, 2001; Mehra et al., 2006; Kalant, 2008). Up to now only two licensed single-compound cannabimimetic pharmaceuticals, Marinol[®] [Dronabinol, (Δ^9 -THC) from Roxane Laboratories (Columbus, OH, USA)] and Cesamet[®] [Nabilone (synthetic analog of Δ^9 -THC) developed at Eli Lilly (Indianapolis, IN, USA)] are on the market (Goutopoulos and Makriyannis, 2002).

Dronabinol is used as appetite stimulant in acquired immunodeficiency syndrome (AIDS) patients and nabilone as an anti-emetic drug against nausea and vomiting caused by cancer chemotherapy (Di Marzo and De Petrocellis, 2006).

Nowadays many pharmaceutical companies are concerned with the multiple cannabinoid-based medicines that may provide better therapeutic success and be better tolerated than the currently available single synthetic cannabinoid medicines that have psychotropic and cardiovascular side effects, such as memory impairment, anxiety, depression, tachycardia etc. The result of this interest is Sativex[®] (GW Pharmaceutical plc, UK), a product containing equal proportions of Δ^9 -THC and cannabidiol (CBD) which is prescribed for the treatment of neuropathic pain in multiple sclerosis. This oro-mucosal spray form of the drug has been available in Canada from 2005 and is currently under regulatory review in the European Union as a treatment against spasticity in patients with multiple sclerosis (Wright, 2007).

Recently rimonabant [a CB₁ antagonist (SR 141716A) developed by Sanofi, France] successfully completed Phase III studies with overweight patients (Van Gaal et al., 2005) and is anticipated to treat cardiometabolic risk factors associated with insulin resistance and abdominal obesity (Van Gaal et al., 2005; Wright et al., 2008). Rimonabant is considered as an ‘‘antimarijuana’’-like agent possessing the opposite of the appetite-stimulating, antinausea, and euphoric effects of Δ^9 -THC. It is currently approved for use in Europe but not in the United States. The reason for the disapproval was the psychiatric adverse effect profile (primarily depression and anxiety) of the drug (Rumsfeld and Nallamotheu, 2008). In addition, clinical trials evaluating rimonabant for smoking cessation treatment were inconclusive (Nides, 2008; Rumsfeld and Nallamotheu, 2008).

Preparations under investigation include the cannabis extract Canador[®] (containing dronabinol and other cannabinoids in a ratio of 2 to 1), ajulemic acid (a synthetic derivative of tetrahydrocannabinolic acid) and cannabior (a synthetic selective CB₂ agonist) (Grotenhermen, 2006).

In the last decade cannabinoid research has achieved significant progress, especially with the discovery of the endocannabinoid system. Particularly interesting will be compounds that interfere with the endocannabinoid metabolism that may be more useful than compounds acting directly upon the cannabinoid receptors. Therefore the future of cannabinoid research is certainly very exciting and full of promise (Pertwee, 2005a; Pertwee, 2008).

1.2 The endocannabinoid system

Although the principal active constituents in marijuana, Δ^9 -THC and CBD had been isolated in 1964 and 1963 respectively by Gaoni and Mechoulam, the mechanism of action of these compounds was not known until the 1990s when the cloning of the first cannabinoid receptor, CB₁ paved the way for a series of important discoveries which unveiled a new, important biological system in humans and other mammals, the endocannabinoid system (Pertwee, 2006a).

As an ubiquitous and complex signalling system, it consists of at least two receptors, CB₁ (Matsuda et al., 1990) and CB₂ (Munro et al., 1993), each with different localizations and functions; a family of endogenous ligands, endocannabinoids (derivatives of arachidonic acid conjugated with ethanolamine or glycerol) and specific molecular machinery for the synthesis, transport, and inactivation of these ligands, all providing potential therapeutic targets in the fields of pain, obesity, drug abuse, stroke, hypertension, asthma, cancer and many others (Makriyannis et al., 2005; Straiker and Mackie, 2006).

1.2.1 Cannabinoid receptors

The cannabinoid receptor family currently includes two receptor types. The CB₁ receptor was first cloned from the rat brain (Matsuda et al., 1990) and subsequently characterized as a pre- or postsynaptically localized receptor in the central and peripheral nervous system. A splice variant of the CB₁ receptor (CB_{1A}) has also been reported with low expression in rodents but does not appear to be expressed in humans (Shire et al., 1995). In 1993 in Munro's laboratories the CB₂ receptor was identified in the periphery by sequence homology (Munro et al., 1993) with predominance on cells of the immune system (Galiègue et al., 1995; Pertwee, 1997; Pertwee, 2001; Lutz, 2002; Pertwee and Ross, 2002) but they are also sparsely expressed in brain. Their expression is upregulated during inflammation in nervous tissue (Felder et al., 2006). The role of the neuronal CB₂ receptor has not been established yet (Pertwee, 2008).

Thus, there is likely to be a clear distinction between the physiological roles of these two subtypes of cannabinoid (CB) receptor. The CB₁ receptor is assumed to be involved in the regulation of cognition, memory, motor activity and nociception (Howlett, 2002; Mackie, 2008), while the CB₂ receptor is likely to participate in the regulation of immune responses and/or inflammatory reactions (Sugiura and Waku, 2000; Klein et al., 2003; Klein, 2005; Felder et al., 2006; Ashton, 2007).

Both belong to the G_{i/o} family of seven transmembrane G protein-coupled receptors (GPCRs) with an extracellular amino terminus and an intracellular C terminus, and CB₁ receptors can also act through G_s or G_{q11} proteins (Howlett et al., 2002). Stimulation of CB₁ and CB₂ receptors can lead to modulation of adenylate cyclase (AC) and phosphorylation and activation of protein kinases such as p42/p44 mitogen-

activated protein kinase (MAPK), p38 MAPK and Jun N-terminal kinase (JNK). All these are elements in signalling pathways regulating nuclear transcription factors and changes in gene expression. In addition, CB₁ receptors can regulate ion channels, probably via G_o proteins (Howlett, 2002; Howlett, 2005). It has been shown that in neural cells they are coupled positively to K⁺ channels [A-type and inwardly rectifying K⁺ (GIRK) channels] and negatively to voltage operated Ca²⁺ channels [N- and P/Q-type Ca²⁺ channels or L-type Ca²⁺ channels (in smooth muscle cells)] and also negatively to inward Na⁺ currents (figure 1.1) (Howlett and Mukhopadhyay, 2000; Howlett et al., 2002; Mukhopadhyay et al., 2002; Demuth and Molleman, 2006).

Moreover, cannabinoid receptor stimulation can induce the production and release of nitric oxide (NO) and modulate the intracellular Ca²⁺ concentrations which mediate many important mechanisms in endothelial cells, immune cells and neurons (Fimiani et al., 1999; Diaz-Laviada and Ruiz-Llorente, 2005; Demuth and Molleman, 2006).

Taken together with the finding that the CB₁ receptor is predominantly expressed presynaptically (and abundantly in cortex, hippocampus, amygdala, basal ganglia, cerebellum and brainstem emetic centers), the action of cannabinoids on these signalling pathways may account for the general inhibition of neurotransmitter release (Lutz, 2002) but the exact mechanism by which cannabinoid receptors modulate neurotransmitter release in neurons is not fully understood (figure 1.1). In contrast, CB₂ signal transduction pathways do not appear to involve ion channel function (Diaz-Laviada and Ruiz-Llorente, 2005; Howlett, 2005).

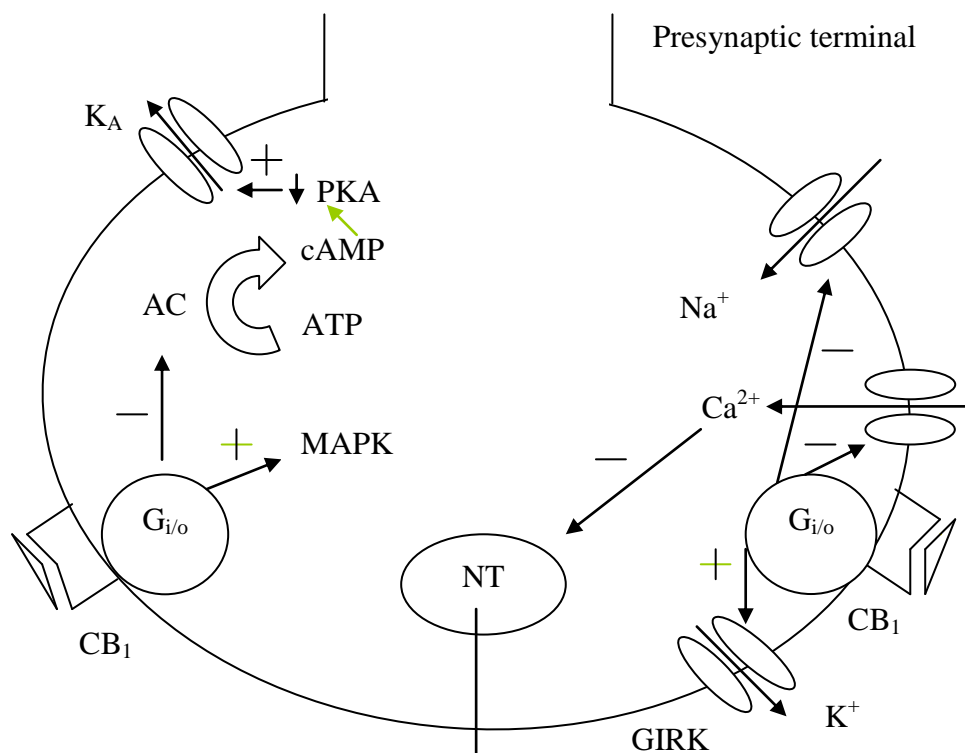

NT-neurotransmitters:
glutamate, gamma-aminobutyric acid, dopamine,

Figure 1.1 Possible mechanisms of cannabinoid-mediated inhibition of neurotransmitter release.

+ denotes activation, - denotes inhibition. The most likely mechanism involves direct modulation of ion channel function: inhibition of voltage operated Ca²⁺ channels (N- and P/Q- type) and Na⁺ currents and vice versa, activation of GIRK channels. CB₁ receptor stimulation through G_{i/o} proteins inhibits AC which in turn activates PKA (protein kinase A) resulting in the phosphorylation of K_A (rapid-inactivating potassium A) channels, serving as another possible model for the inhibition of neurotransmitter release by cannabinoids.

The availability of selective CB₁, CB₂ and non-selective agonists and antagonists, as well as inhibitors of endocannabinoid inactivation and knockout mice, has provided evidence for the existence of additional subtypes of CB receptors in mammalian tissue. One putative novel CB receptor has been found in mouse brain (Breivogel et al., 2001). Freund's group has also reported that a third yet unidentified subtype of cannabinoid receptor (CB₃) may exist at excitatory synapses (Hájos et al., 2001; Hájos and Freund, 2002). As mentioned before, the CB₂ receptor has also been shown to be expressed in brain areas (brain stem, cortex, cerebellum) of mouse, rat and ferret (Van Sickle et al., 2005; Gong et al., 2006). In addition to these putative new CB receptors in the CNS, evidence exists for the presence of a novel receptor for cannabinoids identified as the orphan G-protein-coupled receptor GPR55 (Baker et al., 2006). There is a suggestion of a novel CB receptor in the cardiovascular system, the putative abnormal cannabidiol receptor or the endothelial anandamide receptor, mediating vasorelaxation and reduction of the blood pressure. This receptor is thought to be the GPR55 but the results are not conclusive (Hiley and Kaup, 2007; Johns et al., 2007). Furthermore, there are many reports about the ability of cannabinoid ligands to activate non-CB receptors (e.g. vanilloid receptors) providing new molecular targets for cannabinoid research (Howlett et al., 2002; Pertwee, 2004; Pertwee, 2006b; Pertwee, 2008).

1.2.2 GPR55

Biological activities of cannabinoids are not only mediated through CB receptors as previously thought. Recent reports indicate that cannabinoid ligands also bind to the orphan GPCR, GPR55. There are disputes about its candidacy for the third CB receptor and is described as a candidate for one of the non-CB₁/CB₂ receptors (Baker et al., 2006; Pertwee, 2007b; Ryberg et al., 2007). GPR55 was originally identified *in silico* by performing homology searches, using BLAST (basic local alignment search tool) database resource. These databases are publicly available and maintained by the National Center for Biotechnology Information (NCBI, Sawzdargo et al., 1999). GPR55 belongs to the purinergic subfamily and is most closely related to other orphans GPR35, GPR23 and the purinoceptor P2Y₅ (Baker et al., 2006). Using AurTAG (semi-automatic annotation tool), functional fingerprints of putative binding pockets for cannabinoid agonists with CB₁ and CB₂ receptors were defined and these interactions were compared with the human GPR55 sequence (319 amino acids) aligned with CB₁ and CB₂ receptors. The analysis revealed that the human GPR55 does not share a similar fingerprint with any of the CB₁ and CB₂ receptors. That excludes the possibility that this receptor possesses the classical cannabinoid binding pocket (Petitet et al., 2006). Whether GPR55 is a new member of the cannabinoid receptors remains controversial (Pertwee, 2007b).

Human GPR55 mRNA is expressed in brain, most abundantly in the caudate nucleus and putamen, with lesser levels in the hippocampus, thalamus, pons, cerebellum and frontal cortex. In rats, GPR55 mRNA was detected in hippocampus, thalamic nuclei and regions of the mid-brain. Spleen of humans and rodents also express GPR55 mRNA (Brown, 2007). In mice, the highest levels of GPR55 mRNA were found in

adrenal tissue, ileum, jejunum, frontal cortex and striatum. In lungs the expression level of GPR55 mRNA was low (Ryberg et al., 2007).

1.2.3 Cannabinoid receptor ligands

Originally cannabinoids were classified as C₂₁ groups of compounds present in *Cannabis sativa* L., and currently they are regarded as natural cannabinoids or phytocannabinoids. So far more than 70 cannabinoids have been detected in cannabis. They are categorized into 11 subclasses, of whom the cannabigerol type (CBG), the cannabichromene type (CBC), the cannabidiol type (CBD), the Δ^9 -THC type, and the cannabinol type (CBN) are the most abundant (ElSohly and Slade, 2005; Grotenhermen, 2006).

The modern definition of cannabinoids is formulated with more emphasis on synthetic chemistry. This has prompted the classification of cannabinoids into five chemical groups: classical, nonclassical, aminoalkylindol, eicosanoid and diarylpyrazol (Pertwee, 1997; Goutopoulos and Makriyannis, 2002; Huffman, 2005; Thakur et al., 2005; Pertwee, 2006b).

Classical cannabinoids

This group is represented by plant-derived cannabinoids [(-)- Δ^9 -THC (Δ^9 -THC) (figure 1.2A), Δ^8 -THC, CBN, (-)-cannabidiol (CBD) (figure 1.2A)] and their synthetic analogs such as HU-210, L-nantradol, desacetyl-L-nantradol and the CB₂ selective agonists, JWH-133, L-759633 and L-759656. The main part of their structure contains a dibenzopyran ring.

Nonclassical cannabinoids

The group of bicyclic and tricyclic analogs of Δ^9 -THC lacking a pyran ring was developed by a Pfizer (Groton, CT, USA) research team. It includes CP55940 ($K_i=0.6$ - 5.0 nM and 0.7 - 2.6 nM at CB_1 and CB_2 receptors respectively) with similar affinity for both CB_1 and CB_2 receptors (figure 1.2A), and together with HU-210 ($K_i=0.061$ nM and 0.52 nM at CB_1 and CB_2 receptors respectively) they are some of the most widely used cannabinoids in research. Recently synthesised compounds in this group are CP47497, CP55244 and HU-308 (CB_2 selective).

Aminoalkylindoles (hybrid cannabinoids)

Structurally dissimilar from the members of the first two groups is the third group of compounds developed by Sterling Winthrop (Collegeville, PA, USA). WIN55212-2 [R-(+)-WIN55212] is the most widely investigated aminoalkylindol compound with slightly greater affinity for the CB_2 ($K_i=3.3$ nM) than for the CB_1 receptor ($K_i=62.3$ nM). Its stereoisomer WIN55212-3 [S-(-)-WIN55212] is inactive at CB receptors at least at concentrations less than $1 \mu\text{M}$, a useful property when characterizing CB- and non-CB-mediated responses (figure 1.2A).

Eicosanoids

The two prototypes in this class are the endocannabinoids, natural endogenous ligands for CB receptors, anandamide (AEA) (figure 1.2A) and 2-arachidonylglycerol. It also includes noladin ether, oleamide, virodhamine (VIR) (figure 1.2A) and several synthetic analogues of AEA, including R-(+)-methanandamide, arachidonyl-2'-chloroethylamide (ACEA), arachidonylcyclo-propylamide (ACPA), O-689 and O-1812. R-(+)-methanandamide and O-1812 are more resistant to enzymatic

hydrolysis than AEA, ACEA and ACPA. An endogenous fatty acid amide analogue of AEA is palmitoylethanolamide (PEA) (figure 1.2A).

Diarylpyrazoles

To date, the best characterized CB receptor antagonist is SR141716A (figure 1.2A) developed by Sanofi (Paris, France) which shows selectivity for the CB₁ receptor (K_i=2 nM in the CNS or K_i> 1000 nM in the peripheral nervous system) and also inverse agonism, an effect that is opposite in direction from that produced by an agonist for this receptor. Other CB₁ selective antagonists, LY320135 (developed by Eli Lilly), AM251 and AM281, are synthetic analogs of SR141716A. A novel CB₁ selective antagonist developed recently is SR147778. The most important selective CB₂ antagonists/inverse agonists are SR144528 (K_i=0.6 nM) (figure 1.2A) and AM630 (K_i=31.2 nM) (Pertwee, 2005b).

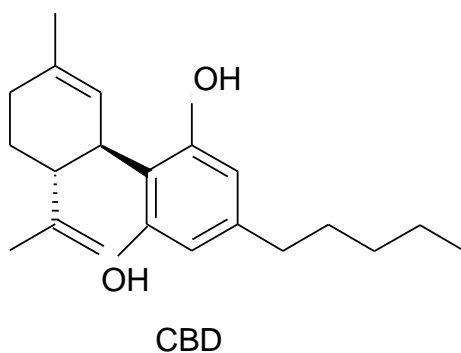
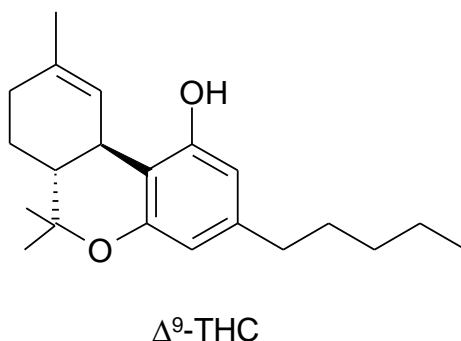

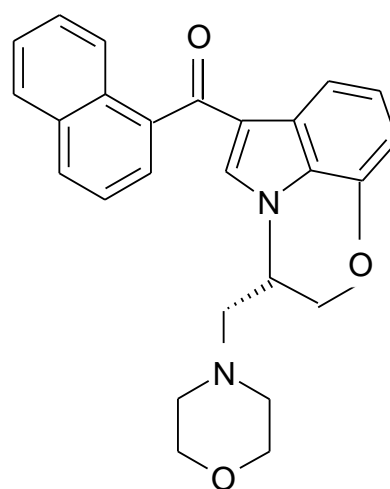
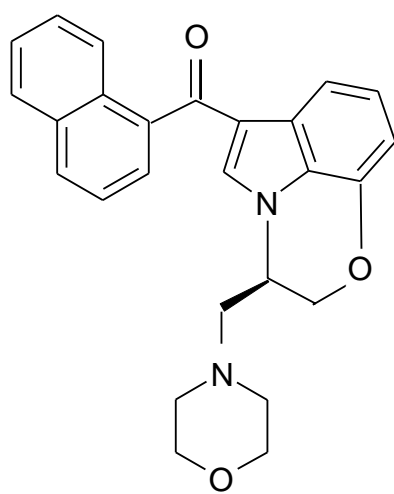
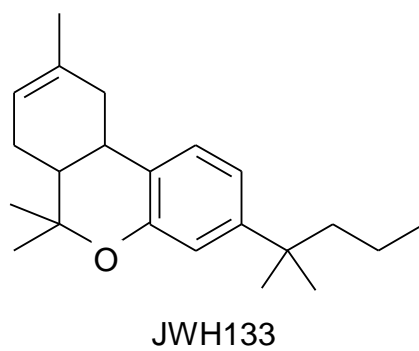
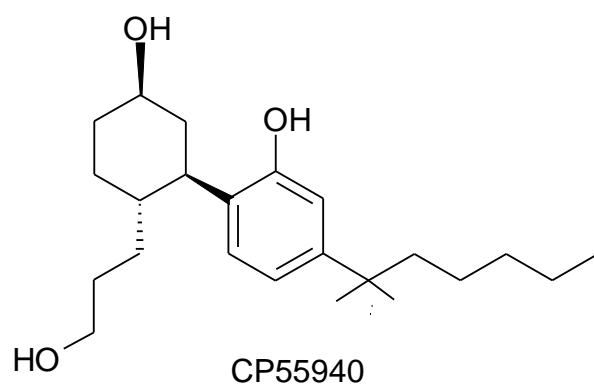

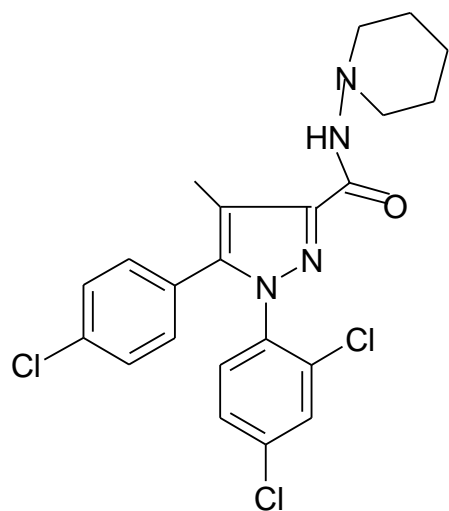

SR141716A

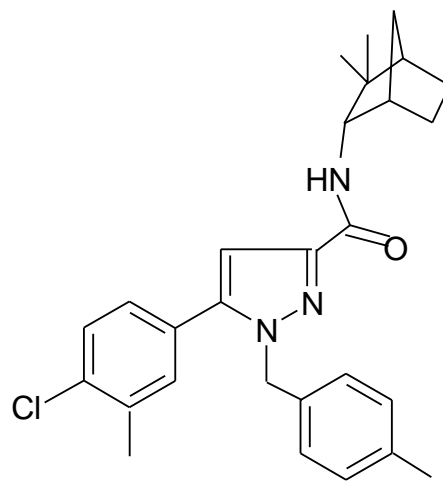

SR144528

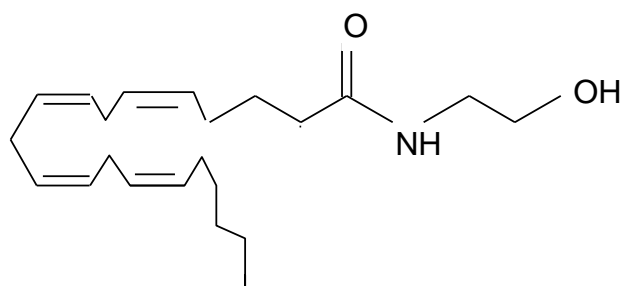

AEA

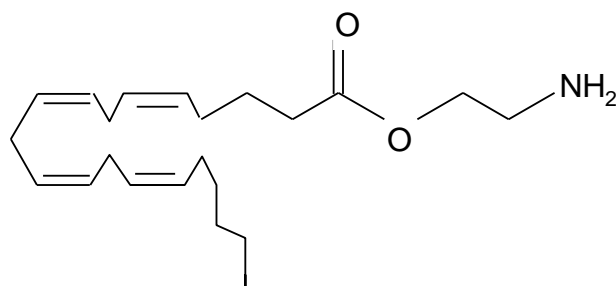

VIR

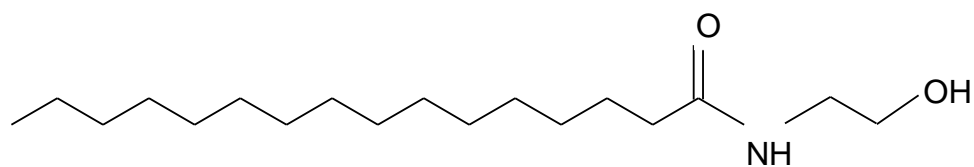

PEA

Figure 1.2A The structures of cannabinoid ligands used in this study.

1.2.4 Endocannabinoids

The discovery of the CB receptors and their G protein-coupled nature led to the search for endogenous CB receptor ligands.

N-Arachidonylethanolamine, an ethanolamide derivative of arachidonic acid, was isolated from porcine brain extracts by Devane et al. (1992) and subsequently named as anandamide (AEA) (figure 1.2A) after the Sanskrit word ‘ananda’ meaning internal bliss. *In vivo* AEA produced the characteristic pharmacological effects of the tetrad of tests used to predict cannabimimetic activity (Fride and Mechoulam, 1993; Palmer et al., 2000; McFarland and Barker, 2004). The term cannabimimetic activity means cannabis-like and can be measured *in vivo* with laboratory animals or *in vitro* with isolated tissues which might contain CB receptors or with cultured cells naturally expressing or transfected CB receptors. The mouse tetrad model gives rise to all cannabinoid effects, i.e. hypothermia, analgesia, catalepsy and hypomotility (Pertwee, 1997). *In vitro* studies have shown that AEA, like other cannabimimetic agents, can affect several signal transduction pathways, such as inhibition of AC, activation of MAPK, inhibition of Ca²⁺ channels, stimulation of GIRK channels, mobilization of the intracellular Ca²⁺ and stimulation of NO production in neuronal and non-neuronal cells (Howlett and Mukhopadhyay, 2000). AEA behaves as a partial agonist at both CB₁ and CB₂ receptors, but has higher affinity for the CB₁ receptor (Howlett et al., 2002).

A second class of endocannabinoids, the 2-acylglycerols, includes 2-arachidonylglycerol (2-AG) which was firstly identified in canine gut and later found in brain at a concentration 170-fold higher than that of AEA (Di Marzo et al., 2000). 2-AG stimulates both CB₁ and CB₂ receptors and appears to be a more

efficacious agonist than AEA, indicating full agonism (Sugiura and Waku, 2000; Mackie, 2008). A detailed description of signalling mechanisms and pharmacological properties can be found elsewhere (Sugiura et al., 2004; Vandevorode and Lambert, 2005). The consequence of the concentration difference between AEA and 2-AG in the CNS is not understood so far (Felder et al., 2006). Both endocannabinoids serving as retrograde synaptic messengers prevent the development of excessive neuronal activity in the CNS, thereby maintaining the homeostasis in healthy and disease states (Pertwee, 2008).

A third endogenously occurring compound, 2-arachidonoyl glycerol ether, named noladin ether, was isolated from porcine brain and has been shown to be an agonist at the CB₁ receptor (Hanuš et al., 2001).

Arachidonic acid and ethanolamine joined by an ester linkage results in o-arachidonoyl-ethanolamine which has been identified by accident in the course of development of a bioanalytical method to measure the AEA level in brain and peripheral tissues. The unknown analyte had the same molecular weight but shorter retention time and based on the molecular structure of opposite orientation, the compound was named virodhamine (VIR) (figure 1.2A) from the Sanskrit word ‘virodha’ meaning opposition (Porter et al., 2002). In comparison to AEA, the concentration of VIR in rat heart, spleen, kidney and skin has been found to be higher, whilst rat brain levels were similar (Porter et al., 2002). VIR displays antagonist and partial agonist activity at the CB₁ receptor and full agonist activity at the CB₂ receptor as demonstrated in a [³⁵S]-GTP_γS binding assay using Sf9 insect cells transfected with both CB receptors (Porter et al., 2002). However, VIR was less potent than either AEA, 2-AG or the synthetic non-selective cannabinoid agonist WIN55212-2. In addition, VIR also inhibited AEA transport but was less potent than the AEA

transport inhibitor, AM404 measured in rat mast cell line, RBL-2H3. *In vivo* VIR produced hypothermia in mice and in AEA-induced hypothermia, VIR acted as an antagonist, indicating that VIR might act as an endogenous antagonist at the CB₁ receptor in the presence of AEA (Porter et al., 2002). Hiley's group demonstrated the ability of VIR to relax the rat isolated small mesenteric artery by the endothelium-dependent activation of Ca²⁺-activated K⁺ channels (K⁺_{Ca}), probably through the putative abnormal-cannabidiol receptor. This effect was inhibited by O-1938, an antagonist for this receptor but not by the selective CB₁ antagonist AM251 or by CB₂ selective antagonists SR144528 and AM630. VIR-induced vasorelaxation was also reduced in the presence of K⁺_{Ca} blockers, apamin and charybdotoxin (Ho and Hiley, 2004). Furthermore, VIR may act as a CB₁ receptor antagonist/inverse agonist in human neocortex. In competition binding experiments VIR inhibited the non-selective cannabinoid agonist [³H]-CP55940 binding which was slightly changed (K_i value representing the affinity was reduced by ~50 %) in the presence of phenylmethylsulphonyl fluoride (PMSF) (figure 1.2B) suggesting the possible degradation of VIR via fatty acid amide hydrolase (FAAH, a key enzyme for AEA hydrolysis, see pages 21-25) in human brain (Steffens et al., 2005). In contrast to AEA and noladin ether, VIR enhanced AC activity in a forskolin-stimulated cAMP assay. Interestingly, AM251 did not further increase the stimulatory effect of VIR, indicating either its pure CB₁ antagonist action or it might possess inverse agonist activity. Another explanation can be that it might couple to a G_s protein in human neocortex (Steffens et al., 2005). The ability of VIR to stimulate AC activity of forskolin-induced cAMP accumulation was also confirmed in the human bronchial epithelial cell line, 16HBE14o-. This effect was mediated by CB₁ receptors and only observed after removing of G_{i/o} response by pertussis toxin (PTX), indicating

coupling to a G_s protein. The predominant VIR-induced inhibition of cAMP formation was via CB_2 receptors coupling to PTX-sensitive G_i/o proteins (Gkoumassi et al., 2007). A recent study revealed for the first time that VIR is a potent inhibitor of fMLP-induced migration of human neutrophils (fMPLP- N-Formyl-L-methionyl-L-leucyl-L-phenylalanine used as a chemotactic peptide). The effect was significantly attenuated in the presence of the CB_1 antagonist, SR141716 but significantly enhanced in the presence of CB_2 antagonists, SR144528 and AM630. The authors concluded that the effect of VIR may involve more than one receptor (McHugh et al., 2008).

The last identified endogenous ligand for the CB_1 receptor thus far is N-arachidonoyl-dopamine (NADA) (Bisogno et al., 2000) which shows cannabimimetic activity both *in vivo* and *in vitro*. In addition, it is a potent agonist at recombinant rat and human vanilloid receptors and also at native vanilloid receptors of dorsal root ganglion neurons and hippocampus in rat (Huang et al., 2002).

Because AEA and 2-AG have received the majority of attention in the endocannabinoids, there is extensive experimental evidence that they play important roles as modulators of physiological functions in the CNS and in the autonomic nervous system and also in the endocrine network, the immune system, the gastrointestinal tract, the reproductive system and in microcirculation (Piomelli, 2003; Rodríguez de Fonseca et al., 2005; Di Marzo and De Petrocellis, 2006; Pertwee, 2008).

1.2.5 Endocannabinoid metabolism

During the past few years, there has been considerable progress in the understanding of the physiological pathways that are involved in the synthesis, release and deactivation of endocannabinoids.

Synthesis and release

Unlike most other neurotransmitters, AEA and 2-AG are not stored in vesicles but they are produced “on demand” to play a protective role when and where they are needed (Di Marzo and De Petrocellis, 2006). Because AEA is the product of the cleavage of a membrane phospholipid and 2-AG (being a monoglyceride) is a metabolic intermediate, different pathways are involved in the synthesis and release of AEA and 2-AG. Once produced, they are released after cellular depolarization or receptor stimulation in a Ca^{2+} -dependent manner and act on the CB receptors located in the cells surrounding the site of production to serve as neuromodulators and immunomodulators or as retrograde synaptic messengers (Kano et al., 2004; Rodríguez de Fonseca et al., 2005; Pertwee, 2006b; Straiker and Mackie, 2006). The standard model of AEA synthesis includes two steps:

- 1.) The synthesis of the membrane lipid precursor N-arachidonoyl phosphatidylethanolamine (NAPE), catalysed by the cellular membrane enzyme N-acyltransferase.
- 2.) The cleavage of NAPE to form AEA, catalysed by phospholipase D (Palmer et al., 2000; Piomelli, 2003).

Two biochemical pathways are responsible for the synthesis of 2-AG. They use arachidonic acid-enriched membrane phospholipids such as inositol phospholipids as

substrates for the combined actions of phospholipase C and diacylglycerol lipase (1,2-diacylglycerol- as the intermediate product). The alternative route of 2-AG synthesis is mediated by phospholipase A₁ and lysophospholipase C (lysophosphatidylinositol-as an intermediate product) (Sugiura and Waku, 2000; Piomelli, 2003).

Deactivation

Two mechanisms co-operate in the termination of endocannabinoid signalling: transport across membranes into cells (uptake) and intracellular hydrolysis and oxygenation.

The first termination step, transport has been most thoroughly studied for AEA. The process displays saturability and substrate specificity and can be blocked by various structural analogs (e.g., AM404, LY2183240, VDM11, arvanil, olvanil). However selective tools for the block of AEA uptake remain to be identified (Felder et al., 2006).

McFarland and Barker (2004) suggested four possible models of AEA transport in neuronal cells (figure 1.3):

A.) Transport by a bidirectional membrane-bound protein carrier which facilitates the uptake in an energy-independent fashion (Hillard and Jarrahian, 2003; Hillard and Jarrahian, 2005). The molecular identification of the putative AEA carrier called AEA membrane transporter (AMT) would allow for a more complete understanding of this carrier-mediated process.

B.) Facilitated diffusion dependent on the activity of FAAH, the intracellular catabolic enzyme primarily responsible for AEA hydrolysis which maintains the inward concentration gradient of AEA and may serve as a driving force for its uptake into cells (Hillard and Jarrahian, 2003).

C.) Sequestration of AEA. This is possible via two mechanisms. First, the lipid character of AEA suggests its association with specific membranous compartments (lipid rafts) that serve as a saturable reservoir for the lipophilic AEA. A second possibility is that AEA may bind to an intracellular protein in a saturable and competitive manner with other molecules.

D.) AEA uptake via caveolae-related endocytosis.

However, these models of AEA transport are not mutually exclusive, and different mechanisms are likely to operate in different cell types (Lambert and Fowler, 2005). Once inside the cell, AEA undergoes the second termination step which is hydrolysis by FAAH resulting in the end products arachidonic acid and ethanolamine. Although FAAH can also break down 2-AG, the most likely enzyme for its degradation is monoacylglycerol lipase (MAG-lipase) to yield arachidonic acid and glycerol (Van der Stelt and Di Marzo, 2004; Vandevorde and Lambert, 2005).

For cells lacking FAAH and MAG-lipase, alternative catabolic routes are available employing cyclooxygenases, lipoxygenases and cytochrome P₄₅₀s (figure 1.3). These oxygenating pathways may lead not only to inactivation of endocannabinoids but also to generation of oxidative metabolites, which in turn could be active either at the CB receptor or at other extra- and intracellular targets (Di Marzo, 2000; Palmer et al, 2000; Van der Stelt and Di Marzo, 2004).

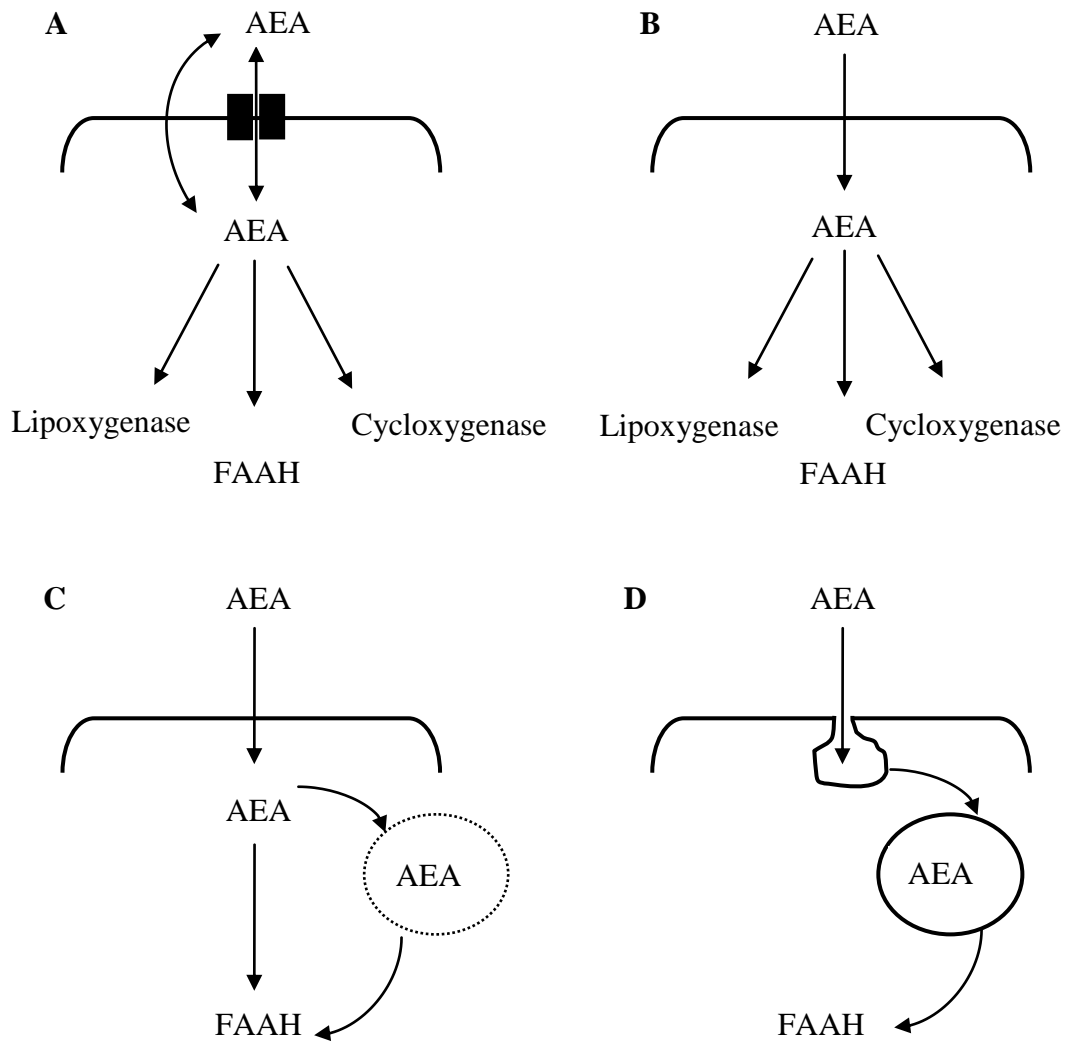

Figure 1.3 Four possible models of AEA transport (modified from Lambert and Fowler, 2005 and McFarland and Barker, 2004).

A, AEA transport across the plasma membrane by the elusive AMT; **B**, FAAH-mediated diffusion serving as a driving force for AEA uptake; **C**, sequestration of AEA in a saturable membrane compartment; **D**, caveolae-related endocytic process of AEA reuptake.

One of the new cannabinoid therapeutic strategies is based on the indirect activation of CB receptors using FAAH inhibitors and AMT inhibitors which are more likely to increase the concentration of endocannabinoids only at sites where ongoing biosynthesis is already occurring, without activating CB receptors at other sites. This approach magnifies the tonic actions of endocannabinoids and their autoprotective role at the onset of some disorders (inflammation, anxiety), and may provide a better safety profile than the direct activation of CB receptors (Van der Stelt and Di Marzo, 2004; Rodríguez de Fonseca et al., 2005; Di Marzo and De Petrocellis, 2006; Pertwee, 2006b).

As previously described the degradation of endocannabinoids is performed by the key enzyme, FAAH which is a membrane-bound enzyme and belongs to the serine-amidase family. The distribution of the FAAH varies between species and is mainly detected in the brain and liver (Vandevorde and Lambert, 2005). The structure elucidation of FAAH opened the way to develop ultrapotent and selective inhibitors and the availability of FAAH deficient mice facilitated the studies. Albeit not selective, PMSF (figure 1.2B) was the first FAAH inhibitor described (Lambert and Fowler, 2005). A new class of potent carbamate inhibitors has been synthesized (Tarzia et al., 2003). URB597 (figure 1.2B), the most potent in this series, has no affinity for CB receptors (Lambert and Fowler, 2005). This compound increases the brain level of AEA (inhibited FAAH activity with $IC_{50}=0.4$ nM) (Kathuria et al., 2003), a finding similar to that reported for FAAH knockout mice. In these mice AEA produced classical behavioural responses in the tetrad which were CB_1 -dependent (Cravatt et al., 2001). Interestingly, URB597 had no effect at the 2-AG level, and did not evoke catalepsy, hypothermia and hyperphagia, key symptoms of the CB_1 receptor activation (Kathuria et al., 2003). Nevertheless, URB597 induced anxiolytic-

like effects in rats and mice which were prevented by the CB₁ antagonist, rimonabant, indicating increased activation of CB₁ receptors (Kathuria et al., 2003; Moreira et al., 2008).

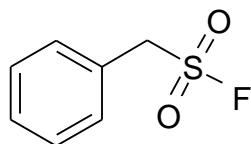

PMSF

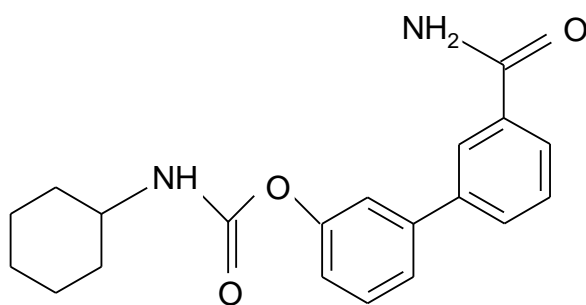

URB597

Figure 1.2B The structures of FAAH inhibitors used in this study.

1.2.6 Pharmacology of GPR55

The pharmacological research in cannabinoid activity of the GPR55 receptor was initiated by two pharmaceutical companies, GlaxoSmithKline and AstraZeneca. The investigation was focused on the detection of receptor activation by agonist ligands (ligand fishing) in two different systems. The group in AstraZeneca used membranes from HEK293 cells transiently transfected with GPR55, and yeast cells expressing GPR55 was the experimental system for the GlaxoSmithKline group. In a [³⁵S]-GTPγS binding assay several cannabinoids including AEA, 2-AG, VIR, PEA, oleoylethanolamide (OEA), noladin ether, Δ⁹-THC, CP55940, HU-210, O-1602 (abnormal CBD analog) behaved as potent agonists at GPR55 in HEK293 cells. Interestingly, CB antagonists, such as SR141716A, AM251 and SR144528 also activated the human GPR55. While VIR appeared to have the greatest intrinsic activity, CBD antagonized CP55940-induced activation of GPR55 (Drmota et al., 2004; Ryberg et al., 2007). GPR55 expressed in yeast was activated only by CP55940, AM251 and SR141716A. In contrast, AEA, 2-AG, VIR, OEA, R-(+)-methanandamide, HU-210, AM630 failed to stimulate GPR55 in yeast (Brown, 2007). In the recombinant cell line used by GlaxoSmithKline group, abnormal CBD was 1000-fold more potent than this in a similar assay performed by AstraZeneca (Johns et al., 2007). GPR55 does not couple to G_i or G_s (insensitive to PTX and cholera toxin treatment) as CB₁/CB₂ receptors do (Drmota et al., 2004), but it couples to G_{α13} which triggers downstream signalling (Ryberg et al., 2007). The G_{α13}-mediated pathway includes activation of small G proteins, rhoA, cdc42 and rac1. It has been shown that AEA and O-1602, (both at 1 μM) activated the expression of rhoA, cdc42 and rac1 proteins. The activation was blocked by CBD (10 μM) identified by western blotting

in GPR55 recombinant cells (Ryberg et al., 2007). In addition, in HEK293 cells transfected with GPR55 and large dorsal root ganglion neurons (expressing high levels of GPR55) cannabinoid agonists such as Δ^9 -THC, AEA, R-(+)-methanandamide and JWH015 evoked an increase in intracellular Ca^{2+} which was stimulated by activation of GPR55 (Lauckner et al., 2008).

The presence of GPR55 was also suggested in vascular smooth muscle (Baker et al., 2006) because cannabinoids tend to cause vasodilation which is not mediated by CB_1/CB_2 receptors. Abnormal CBD, O-1602 (atypical cannabinoids as agonists) and O-1918 (as antagonist) provide important research tools to evaluate the candidacy of GPR55 for the vascular cannabinoid receptor. There is controversy over the possible cardiovascular role of GPR55 in mice. On one hand, the AstraZeneca group claims hypertension in GPR55 knockout mice (Hiley and Kaup, 2007). On the other hand, Johns et al. (2007) report no significant difference in basal heart rate and blood pressure in control and GPR55 ablated mice. The hypothesis that GPR55 may be present and functional in the vasculature was weakened by the observation that O-1918 inhibited vasodilation of mesenteric arteries to abnormal CBD equally in wild type and knockout mice (Johns et al., 2007). Although the potency of O-1918 was not tested in membranes from HEK293 cells expressing human GPR55, both atypical cannabinoids (abnormal CBD and O-1602) stimulated $\text{GTP}\gamma\text{S}$ activity with similar potency (2 nM). This indicates agonism of atypical cannabinoids at GPR55 and potential non-specific (non-GPR55) mediated effects (Johns et al., 2007).

Recently, a study suggested that GPR55 might play a role in hyperalgesia (Staton et al., 2008). Using a pain model, GPR55 knockout mice in comparison to their control littermates failed to develop hyperalgesia induced by Freund's adjuvant. Levels of cytokines to inflammatory insults in paws of mutated mice compared to control mice

have been shown to be elevated. This indicates that GPR55 manipulation might be utilised for pain treatment (Staton et al., 2008).

In addition, the available data do not exclude the possibility that GPR55 might be targeted by different non-cannabinoid ligands. Recently, lysophosphatidylinositol, a degradation product of phosphatidylinositol, acting as a lipid mediator, has shown phosphorylation of ERK (extracellular signal-regulated kinases, involved in a wide variety of cellular processes such as proliferation, differentiation, transcription regulation and development), and Ca^{2+} transients in HEK293 cells expressing GPR55. Importantly, this bioactive lipid stimulated the binding of [^{35}S]-GTP γ S to the membranes with GPR55. The results imply that GPR55 is a lysophosphatidylinositol receptor (Oka et al., 2007). Further investigation is required to reveal and understand the pharmacology of GPR55 (Pertwee, 2008).

1.3 Cannabis and asthma

Could marijuana be used as an anti-asthmatic agent? A study from 1973 has investigated the effect of a single dose of marijuana smoke in humans. The major active component of cannabis, Δ^9 -THC, caused a bronchodilation manifested by reduction of airway resistance and increase of airway conductance (Vachon et al., 1973). This effect is not due to either an antimuscarinic or a β -adrenergic agonist action (Tashkin et al., 1975). Because marijuana smoking (Tashkin et al., 1975) and oral administration (Davies et al., 1975; Abboud and Sanders, 1976; Hartley et al., 1978) of Δ^9 -THC have not appeared to be suitable for possible therapeutic purposes (local irritation and low bioavailability respectively), the potential of aerosolized Δ^9 -THC has been investigated. A comparative study of smoked, oral and inhaled Δ^9 -THC in healthy and asthmatic subjects resulted in the exclusion of aerosolized Δ^9 -THC for clinical treatment because of local irritating effects on the airways (Shapiro et al., 1977; Tashkin et al., 1977). However, the exact mechanism of Δ^9 -THC-induced bronchodilation still remains unknown (Graham, 1986). Nowadays the prevailing opinions about the role of cannabis as medicine are disputable. The main concern is related to a suggestion that regular marijuana smoking could contribute to cancer risk, particularly, to cancer of the lung, head and neck. The carcinogenic potential of marijuana arises from the presence of carcinogens and co-carcinogens (vinyl chlorides, phenols, nitrosamines, reactive oxygen species, polycyclic aromatic hydrocarbons) in the tar from cannabis, similar harmful particles are also found in the tobacco smoke (Tashkin et al., 1980; Tashkin et al., 2002). Important is the fact that one joint of cannabis is similar to 2.5-5 tobacco cigarettes in terms of causing airflow obstruction (reduction of the airway conductance) (Aldington

et al., 2007). This might indicate that smoked marijuana is even more harmful than tobacco smoke. Regarding the respiratory symptoms, wheeze, cough and sputum production (chronic bronchitis) were associated with cannabis smoking and tobacco smoking, while chest tightness was associated only with cannabis smoking. From pulmonary structure changes, cannabis smokers had decreased lung density, whereas macroscopic emphysema was typical only for tobacco smokers (Aldington et al., 2007). Noteworthy is the deeper inhalation technique, i.e. higher tar exposure to the lungs in cannabis smokers and the shorter breath holding characteristic of tobacco smoking. These properties might suggest marijuana had an impact on cancer risk. To reduce toxic by-products of smoked cannabis primarily produced by combustion, vaporization offers a smokeless cannabis delivery system minimizing pulmonary complications and stimulating potential therapeutic effects of cannabis (Abrams et al., 2007; Earleywine and Barnwell, 2007). An additional delivery method such as sublingual spray may offer a possibility to avoid the side effects of chronically used marijuana (Baker et al., 2003). The understanding of a possible association between marijuana use and cancer and the potential for additive or synergistic effects between marijuana and tobacco smoking needs further investigation focusing on pharmacokinetic analyses of tobacco and non-tobacco smokers who smoke marijuana for medical or recreational purposes. The increased adherence to methodologic standards in future studies and adequate educational communication between physicians and patients regarding side effects are desirable (Hashibe et al., 2005; Mehra et al., 2006).

Although cannabis is not prescribed to treat respiratory conditions anymore, the current knowledge of the potential role of cannabinoids in the airways is insufficient. There is a need to further investigate the respiratory pharmacology and physiology of

cannabinoids which might reveal novel targets for the development of anti-asthmatic agents. In order to characterize asthma (chapter 1.5), it is essential to briefly describe the airway smooth muscle and the innervation of airways.

1.4 Airway smooth muscle and airway innervation

The tissue of the airway smooth muscle (ASM) plays an important role in the homeostasis of the respiratory system, regulating the diameter and length of conducting passageways, and hence controlling dead space and resistance to airflow to and from the gas-exchanging areas of the lung (Canning, 2006).

The recognition of the existence of innervated airways goes back to the 17th century when Bartholinus (1663) first described nerve branches supplying human bronchi (Barnes, 1986). In the beginning of the 20th century, two physicians, Dixon and Brodie made the notable observation that the autonomic nervous system (ANS) innervates the airways which can regulate the ASM tone (Dixon and Brodie, 1903). Later it became clear that the ANS is responsible for other aspects of the airway function as well, such as glandular secretion and regulation of the airway vasculature (Barnes, 1986).

The autonomic control of airway calibre is a complex process that includes parallel excitatory and inhibitory afferent and efferent pathways (figure 1.7) and any autonomic abnormalities may contribute to airway diseases such as asthma or chronic obstructive pulmonary disease (COPD) (Canning, 2006).

Airway efferent innervation arises both from the sympathetic and parasympathetic subdivisions of the ANS. The dominant neural contractile mechanism of ASM in all animals, including humans, is parasympathetic and cholinergic in nature (Barnes,

1986). Airway relaxation is primarily mediated by noncholinergic-parasympathetic nerves. Sympathetic-adrenergic innervation of human airways appears from ultrastructural studies to be sparse and may differ between animal species (Canning and Fischer, 2001; Canning, 2006).

Stimulation of efferent cholinergic nerves originates in the vagus nerve, runs down to ganglia in the airway wall associated with the neural plexuses and activates postganglionic nerve fibres to release acetylcholine (ACh) (figure 1.7), a neurotransmitter acting on M_2 and M_3 muscarinic receptors of target smooth muscle cells, resulting in their contraction (Roffel and Zaagsma, 1994; Barnes, 1999). In comparison to bronchoconstrictor M_3 receptors, M_2 receptors are prejunctional and auto-inhibitory to ACh release in parasympathetic nerves (Barnes, 1999), for that reason M_3 -selective antagonists are more effective bronchodilators in the treatment of asthma (Barnes, 2006b).

Inhibition and/or excitation (in some species) of ASM can be stimulated by sympathetic nerve fibres which originate from sympathetic cervical and thoracic ganglia of the spinal cord. The primary sympathetic neurotransmitter is noradrenaline (NA) (figure 1.7) acting on α - and β - adrenoceptors (Goldie, 1990; Ind, 1994; Canning and Fischer 2001). While α_1 - and α_2 - (presynaptic) adrenoceptors mediate bronchoconstriction in various animal models, the major adrenergic relaxant response in man is mediated through the β_2 -adrenoceptor (Goldie et al. 1990) and selective agonists for this receptor such as salbutamol remain the most widely used drugs for asthma in the world today (Barnes, 2006b).

In addition to cholinergic and adrenergic innervation, the contraction/relaxation of the ASM can be mediated by anatomically and functionally separate sensory nerves. This sensory innervation can be demonstrated by electrical stimulation (in the presence of

muscarinic and adrenergic blocking agents) and involves non-adrenergic non-cholinergic (NANC) nerves with their own inhibitory [vasoactive intestinal polypeptide (VIP) and NO] (figure 1.4) and excitatory [tachykinins-substance P (SP), neurokinin A (NKA), neurokinin B (NKB), and calcitonin gene related peptide (CGRP)] neurotransmitters (figure 1.6) (Ellis and Udem, 1994a). Apart from contracting and/or relaxing the ASM, NANC nerves can mediate vasodilatation and/or vasoconstriction, mucus secretion, and inflammatory and immune cell function, thus playing an important role in the physiology and pathophysiology of the respiratory tract (Barnes et al., 1991).

It has been established that the activation of sensory nerves is mediated centrally via afferent nerves while the sensory efferent function is due to the local axon reflex. The majority of sensory nerve fibres originate from two vagal sensory ganglia- nodose and jugular and only a minority of sensory nerve fibres run together with spinal sympathetic nerves originating from the dorsal root ganglia (Belvisi, 2003; Groneberg et al. 2004).

There are two broad categories of airway afferent sensory nerves, myelinated fibres classified as ‘‘A-fibres’’ conducting action potentials at a fast rate (10-50 m/ s) and non-myelinated ‘‘C-fibres’’ which conduct action potentials at a slow velocity (0.3-2 m/ s) (Spina, 1996; Udem and Carr, 2002; Clark and Udem, 2006). A-fibres supply stretch receptors that respond to mechanical stimuli caused by the inflation and deflation of respiration. On the base of adaptation properties to a sustained inflation, stretch receptors can be subdivided into slowly adapting receptors (SARs, localized predominantly in ASM) and rapidly adapting receptors (RARs, found within and below the airways epithelium) (figure 1.4) (Clark and Udem, 2006).

Activation of SARs leads to the inhibition of inspiration prolonging expiration at high lung volumes (Breuer-Hering inflation reflex) and also to a reflex bronchodilation by inhibiting vagal tone (Barnes, 1986; Canning and Fischer, 2001). Conversely, RARs adapt more quickly and fire irregularly. They are activated by smooth muscle contraction after exogenously applied muscarinic agonists or by gas irritants (cigarette smoke, ammonia, sulphur dioxide, ozone) or by inflammatory mediators (histamine, serotonin, PGF_{2α}) resulting in bronchoconstriction, coughing and stimulation of breathing, and reflex mucus secretion (Barnes, 1986; Spina, 1996; Canning and Fischer, 2001).

In comparison to RARs and SARs which are sporadically activated during the respiration, unmyelinated C-fibres classified as nociceptors (figure 1.4), are quiescent in normal lungs but are adapted to respond to the threat of tissue damage (Canning and Fischer, 2001; Clark and Udem, 2006) and represent approximately 75 % of the afferent vagal fibres innervating the respiratory tract (Lee et al., 2003). The sensitivity of nociceptors is mainly exemplified by the pungent ingredient in hot chilli peppers, capsaicin, and also by phenylbiguanide, bradykinin, histamine, prostaglandins F_{2α}, E₂, I₂, and sulphur dioxide (Barnes, 1986; Spina, 1996). On the basis of their accessibility to chemicals injected into arteries, nociceptors are distinguished as pulmonary (activated with a short latency by injection of capsaicin into the right atrium or pulmonary artery) and bronchial receptors that are activated with a delay by capsaicin injection into the left atrium or the right heart. They are strongly stimulated by prostaglandins, bradykinin and histamine. In contrast, pulmonary C-fibres do not respond to autacoids and they are activated by hyperinflation triggering pulmonary chemoreflex (apnea, hypotension, bradycardia). Stimulation of afferent C-fibre endings either by pulmonary or bronchial receptors leads to cough and/or reflex

bronchoconstriction (Karlsson et al., 1988). A more detailed description of sensory C-fibres and their function is provided in the chapter 1.6.

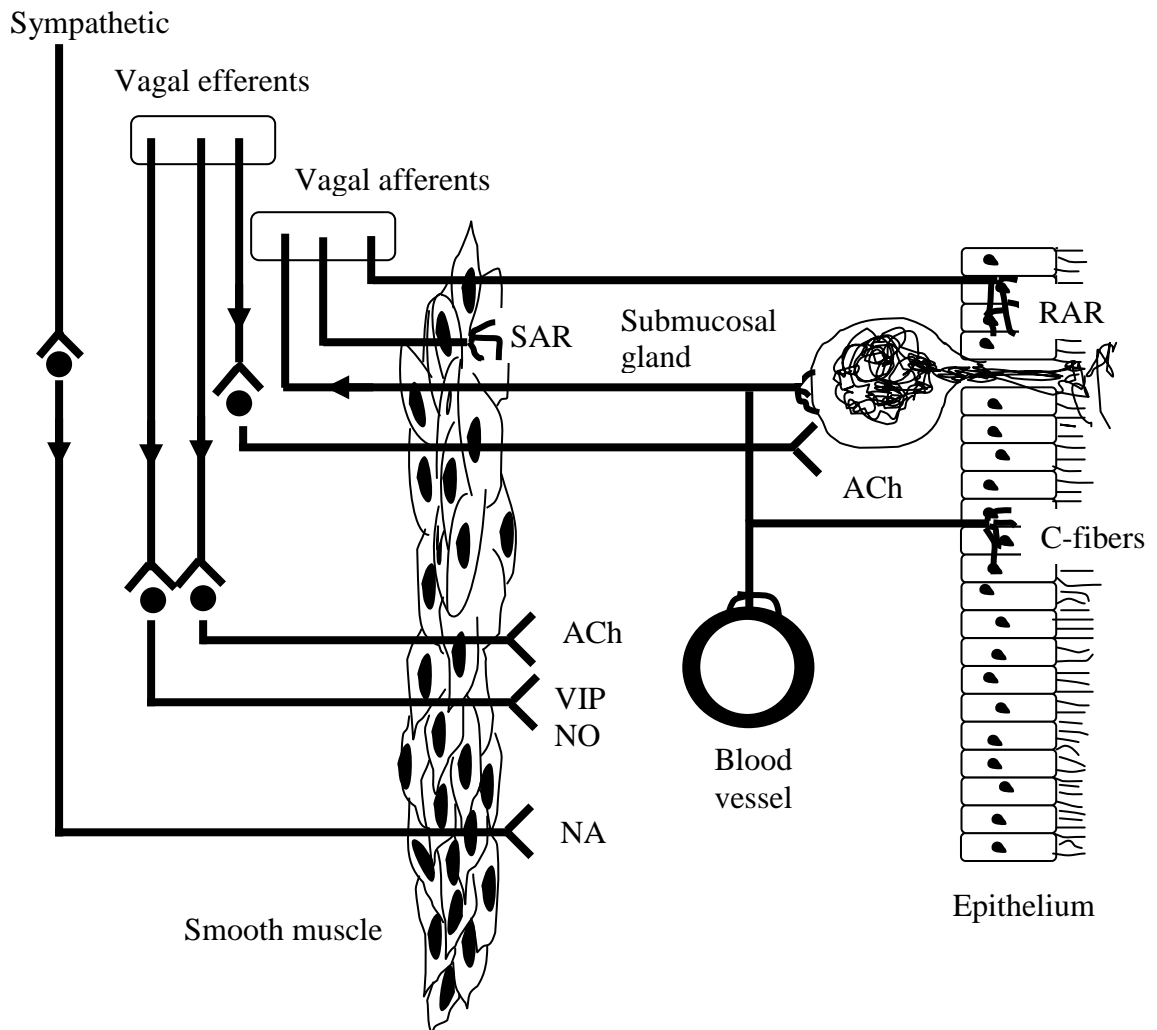

Figure 1.4 Innervation of the human airways.

Afferent vagal innervation is composed of myelinated axons consisting of RARs and SARs, and unmyelinated bronchopulmonary C-fibres. Efferent innervation consists of vagal cholinergic fibres, vagal NANC fibres, and extra-vagal sympathetic adrenergic fibres. C-fibres ramify widely and are associated with glands, epithelium and vasculature.

1.5 Asthma

In industrialised countries, asthma has become one of the most common chronic diseases where it accounts for 1 % of all healthcare costs. But also in developing countries its frequency has been increased (Belvisi et al., 2004; Barnes, 2006b). According to the World Health Organization, from 300 million asthma sufferers, 255 000 died of asthma in 2005 and the number of deaths is predicted to increase by almost 20 % in the next decade.

Asthma is a chronic inflammatory disease of the airways that involves symptoms such as wheezing, breathlessness, chest tightness and cough (Belvisi et al., 2004; Jeffrey and Haahtela, 2006). The degree of inflammation is related to the airway hyper-responsiveness, an abnormal increase of airflow limitation in response to pharmacological and irritant stimuli. These different stimuli (allergens, drugs, exercise, infections, air pollutants) result in bronchoconstriction that is an important pathophysiological feature of bronchial asthma (Schoor et al., 2000). The airway inflammation is due to the activation of inflammatory and structural cells (ASM cells, epithelial and endothelial cells) which release inflammatory mediators, all of which contribute to the clinical manifestations of asthma (Barnes, 1996b; Barnes et al., 1998).

Clinically, asthmatics are classified into three categories. First, extrinsic (allergic) asthma is associated with atopy, defined by the presence of elevated levels of total and allergen-specific immunoglobulin E (IgE) in the serum of patients, leading to allergic reactions. It includes both genetic and environmental factors. Second, intrinsic (non-allergic) asthma is not IgE related and is evoked by a myriad of factors (aspirin, cold air, exercise, chest infection, stress, laughter etc). Third, occupational

asthma develops after exposure of specific proteins or small molecular weight chemicals at work (Corrigan and Kay, 1992). In many subjects, the asthmatic attack consists of two main phases. The early asthmatic response (EAR) occurs immediately after challenge and reaches a peak after 10-20 min. This is followed by a late asthmatic response (LAR) reaching a peak at 4-8 hours and persisting at least for 12 hours. The phases can be demonstrated by monitoring the forced expiratory volume in one second (FEV_1), as a standard lung function test introduced by Tiffeneau and Pinelli in the 1940s in France, to measure airflow obstruction and assess bronchoprovocation, including allergen challenges (Cockcroft, 1983; Bentley et al., 1997; Cockcroft et al., 2007).

The pathogenesis of asthma is a complex process involving eosinophils, T helper 2 (Th2) lymphocytes, mast cells, neutrophils and macrophages as key inflammatory cells activated in asthmatic airways (Barnes, 1996b; Barnes, 2006a; Bloemen et al., 2007). The most crucial inflammatory mediators of allergic asthma, particularly cytokines produced by Th2 cells, interleukin 4 (IL-4), interleukin 5, (IL-5), interleukin 9 (IL-9) and interleukin 13 (IL-13), play an important role in humoral immune responses that consequently result in increased airway responsiveness to provocative stimuli (Barnes et al., 1998; Jan et al., 2003; Montuschi et al., 2007). The origin of Th2 cells stems from the interaction of three elements, $CD4^+$ T lymphocytes, the allergen (antigen) and antigen-presenting cells (APC) with the peptide called the major histocompatibility complex MHC II (figure 1.5) (Corrigan and Kay, 1992; Holt, 2000; Belvisi et al., 2004; Holgate and Polosa, 2008). The population of antigen-presenting cells is mainly represented by dendritic cells, localised within and below the epithelium. The process of endocytosis mediates the antigen uptake by them (Holt, 2000). In occupational asthma, the majority of T cells derive from $CD8^+$ T

lymphocytes which may cause bronchial eosinophilia (via IL-5) but not specific IgE production (absence of IL-4) (Baraldo et al., 2007). In addition to the Th2 paradigm, the airway inflammation can be mediated through T helper 1 (Th1) lymphocytes, eliciting delayed type of hypersensitivity reaction. Th1 cells produce interleukin-2 (IL-2), interferon- γ (IFN- γ) and tumor-necrosis factor alfa (TNF- α). While IL-2 targets a broad range of lung cells, IFN- γ enhances the cytotoxic function of lung macrophages and lymphocytes and suppresses the synthesis of IgE (figure 1.5) (Baraldo et al., 2007; Bloemen et al., 2007).

In atopic asthma, IL-4 promotes differentiation of Th0 cells into the Th2 phenotype to promote B cell differentiation and IgE production, and upregulates IgE receptors. Additionally, IL-4 secretion is associated with eosinophilic airway infiltration. IL-5 promotes development, differentiation, recruitment and activation of eosinophils. IL-9 promotes inflammation and airway hyper-responsiveness. IL-13 can mediate allergen-induced hyper-responsiveness (figure 1.5) (Barnes et al., 1998; Jan et al., 2003; Baraldo et al., 2007).

Eosinophils are associated with the late asthmatic response as prime pro-inflammatory effector cells causing bronchial damage (Durham and Kay, 1985; Corrigan and Kay, 1992; Humbles et al., 2004). Eosinophil accumulation in the bronchoalveolar lavage fluid (BAL) and bronchial biopsy specimens correlated to enhanced airway responsiveness in asthmatic subjects (Wardlaw et al., 1988; Robinson et al., 1993). In mice an elevated number of eosinophils in BAL fluid and increased bronchial responsiveness to carbachol and serotonin were found after allergen inhalation challenge. In contrast, in actively immunized IL-4 knockout mice, the bronchial responsiveness to serotonin was not changed, compared with the saline-exposed control group. This confirms the role of IL-4 in the pathogenesis of bronchial hyper-

responsiveness (Brusselle et al., 1994). Chronic eosinophilia with epithelial fragility and its reticular membrane thickening (deposition of collagen under the airway epithelia, i.e. subepithelial fibrosis) contribute to remodelling. Furthermore, myocyte hypertrophy and hyperplasia also lead to these structural alterations of small airways (Brewster et al., 1990; Jeffery and Haahtela, 2006; Bloemen et al., 2007).

In severe asthma, the predominant infiltrating inflammatory cells are neutrophils and macrophages (Barnes, 2006a). Macrophages, being the most abundant cells in the lungs (Bentley et al., 1997), affect the airway inflammation in two ways. Their pro-inflammatory role stems firstly from the secretion of cytokines and chemokines, which results in the recruitment and activation of other inflammatory cells, and secondly in antigen presentation. In contrast, macrophages contribute to the prevention and inhibition of allergic inflammation by the secretion of inhibitory mediators (prostaglandin E₂, PGE₂) (Barnes, 1996b; Bloemen et al., 2007). The characteristic feature of neutrophilic inflammation is increased IL-8 production. In asthmatic airways, the damaged bronchial epithelium participates in the complexity of the disease. A marker of epithelial stress, the epidermal growth factor receptor (EGFR) is an important factor for epithelial growth and differentiation. It has been shown that the expression of the EGFR correlated with IL-8 production, indicating the potential of EGFR to contribute to neutrophilic inflammation (Hamilton et al., 2003). Importantly, an increased level of TNF- α is associated with severe corticosteroid dependent asthma and the potential of anti-TNF- α treatment is under clinical investigation (Howarth et al., 2005; Berry et al., 2006). Also, leukotriene B₄ (LTB₄, a lipid mediator derived from arachidonic acid through the 5-lipoxygenase pathway) is a potent neutrophil chemoattractant that enhances neutrophil-endothelial interactions and stimulates neutrophil activation (Chanez et al., 2007; Montuschi et al., 2007).

For many years it has been assumed that mast cells are linked only to the early phase asthmatic reaction, i.e. initiating the event of allergen-induced bronchoconstriction (Casale et al., 1987). More recently it has become clear that mast cells, through cytokine production (e.g. IL-4, IL-13), antigen presentation and antigen transport, can contribute to the expression of late phase reactions in airways and tissue remodelling (Williams and Galli, 2000; Kraft et al., 2003). The bronchoalveolar lumen of asthmatic patients showed increased expression of mast cell population, suggesting their migration from the lung tissue (Tomioka et al., 1984). Mast cell migration might be mediated by chemokines (inflammatory cell chemoattractants, C-C and C-X-C chemokines), and growth factors, released by the airway epithelium and smooth muscle that exhibit mast cell chemotactic activity. These mechanisms might control the microlocalization of mast cells to different parts of the airway wall with predominance to the airway epithelium, the airway mucous glands and the ASM (Singer et al., 2004; Brightling et al., 2005; Woodman et al., 2006; Bloemen et al., 2007; Bradding, 2007). The ASM may provide the pivotal microenvironment for mast cell function and their interaction could be relevant in the development of airflow obstruction and airway hyper-responsiveness, suggesting a critical determination of the asthmatic phenotype (Brightling et al., 2002; Robinson, 2004; Bradding et al., 2006; Bradding, 2007; Bradding and Brightling, 2007). In addition, mast cell microlocalization within submucosal glands can contribute to mucus plugging, resulting from mucus hypersecretion and the release of numerous mast cell products (Bradding, 2003; Bradding et al., 2006).

A short overview of key concepts in mast cell biology is provided in chapters 1.7 and 1.7.1.

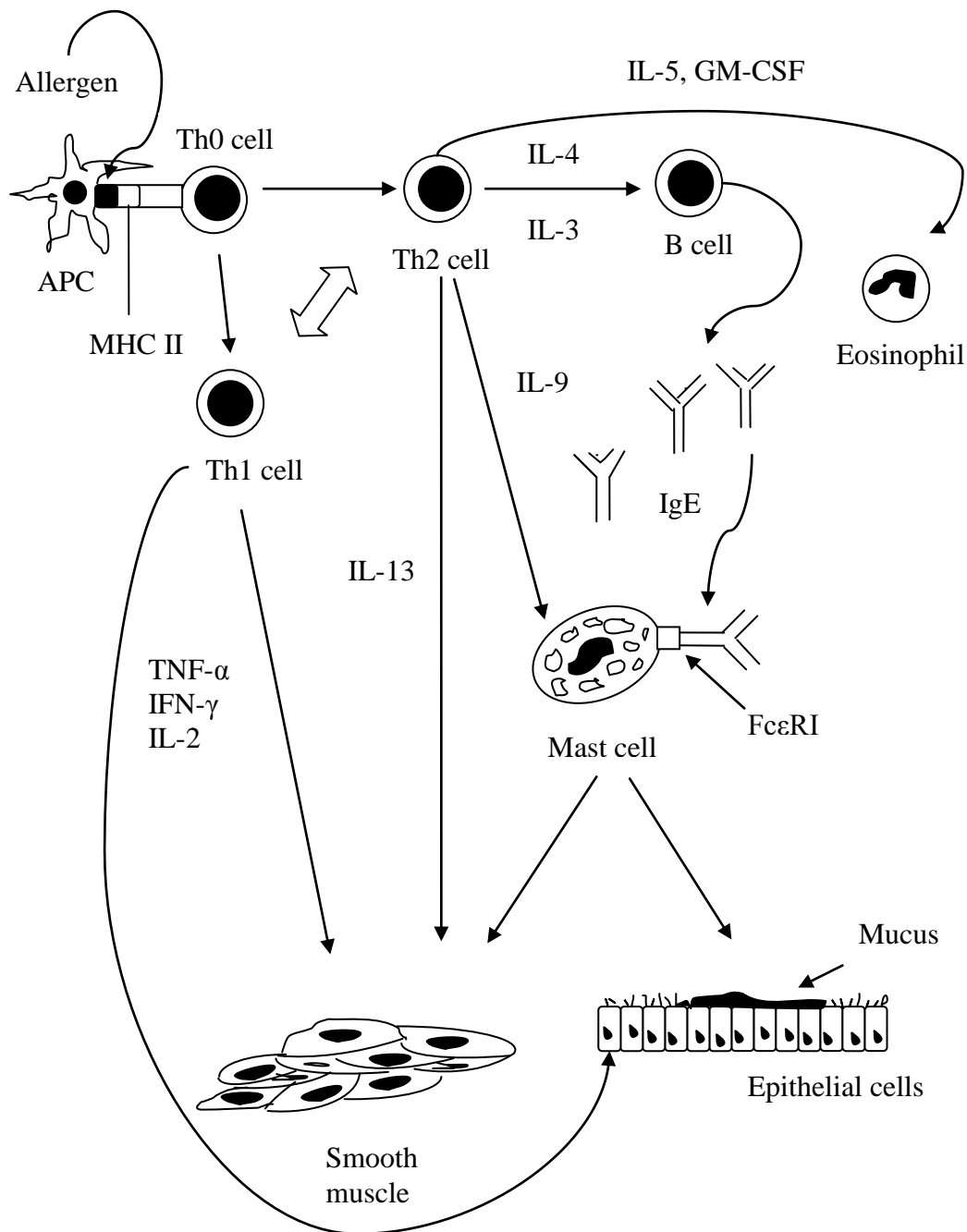

Figure 1.5 Classical mechanisms of allergic asthma (Holgate and Polosa, 2008; Singh and Kraft, 2008).

In predisposed individuals, an allergen is taken up by APC what leads to the activation of T cells. The T cell response is balanced between the Th1 and Th2 response by cytokines, chemokines and other populations. The Th2-mediated reaction results in the production of B cells which secrete IgE. These IgE molecules have the ability to bind to FcεRI receptors on effector cells such as mast cells. Crosslinking of allergen to receptor-bound IgE causes degranulation and subsequent release of numerous inflammatory mediators. The resulting acute and chronic inflammation results in airway disease and symptoms of asthma. The Th1-mediated response might also be responsible for some of the pathological features of chronic asthma (epithelial apoptosis and smooth muscle activation).

1.6 Sensory nerves

It is generally accepted that the cholinergic system is crucial in the ASM control and the tachykinergic system appears to be more species specific. Noteworthy is that there are no reports which would highlight any species differences in the capsaicin-sensitive afferent function of C-fibres. The capsaicin-sensitive efferent function plays only a sparse role in human airways but a dominant role in rodent airways (Karlsson, 1994). The latter is mediated through excitatory NANC (eNANC) nerves (Ellis and Udem, 1994a) and histological and pharmacological studies showed that eNANC nerves form a diffuse network immediately below the epithelium directly innervating ASM, submucosal glands and blood vessels (Barnes et al., 1991). The activation of eNANC nerves results in a local or axon reflex causing the release of sensory neuropeptides (tachykinins and CGRP) and neurogenic inflammation (figure 1.6) (Barnes, 2001; Belvisi, 2003; Groneberg et al., 2004).

1.6.1 eNANC responses

A pivotal study of NANC contractile responses of ASM has been conducted by Grundström et al. (1981) in the guinea-pig *in vitro*. Electrical field stimulation (EFS) of the main and hilar bronchi induced a biphasic response. The first cholinergic twitch was rapid, short lasting, and abolished by atropine. The second atropine-resistant response was long lasting with slow onset, and named as non-cholinergic (Grundström et al., 1981). Also, *in vivo* eNANC responses have been observed by vagus nerve stimulation in anaesthetized guinea-pigs. The activation of capsaicin-sensitive sensory neurons produced bronchospasm that was only partly inhibited by atropine and the ganglionic blocker hexamethonium (Lundberg and Saria, 1982). In human bronchi NANC contractile responses to nerve stimulation are not so potent, probably due to simultaneous release of smooth muscle relaxant neurotransmitters such as VIP. Only one isolated human bronchial ring preparation out of four tissues studied produced a small tetrodotoxin (TTX)-sensitive eNANC effect (Lundberg et al., 1983). Intermittent field stimulation of human bronchi and guinea-pig trachea has shown a predominantly non-adrenergic inhibitory mechanism, while non-cholinergic atropine-resistant response could not be observed in these species (Taylor et al., 1984). Currently, the existence of eNANC mechanisms in human airways is unclear (De Swert and Joos, 2006) and it is worth pointing out that guinea-pig airways might represent an appropriate model for studying nerve mediated respiratory functions triggered by tachykinins under both normal and pathological conditions (Ellis et al., 1993; Corboz et al., 2003).

1.6.2 Tachykinins

The predominant respiratory tachykinins, SP and NKA, belong to a family of peptides which share the common C-terminal sequence Phe-X-Gly-Leu-Met-NH₂ containing the biologically active domain (Ellis and Udem, 1994a). Together with numerous other molecules including neuropeptide tyrosine (NPY), VIP, CGRP, endogenous opioids and NO, they belong to a class of neuromediators targeting not only residential cells but also inflammatory cells. Because of this they are called pro-inflammatory neuromediators and contribute to the development and progression of bronchial asthma and COPD (Groneberg et al., 2006). In the guinea-pig lung and trachea, retrograde neuronal tracing and double-labelling immunohistochemistry revealed the co-localization of SP, NKA and CGRP suggesting that these neuropeptides are present in the same terminals (Kummer et al., 1992). An anatomical and electrophysiological study investigating the number of SP-immunoreactive nerve fibres in guinea-pig showed that tracheal ganglia contained fewer SP-immunoreactive neurons than the bronchus (Myers et al., 1996). In comparison to the guinea-pig airways, human tachykinergic innervation is sparse, and SP and NKA nerve fibres are mainly in the smooth muscle layer and around local bronchial ganglia (De Swert and Joos, 2006; Groneberg et al., 2006). In addition to neuronal sources, SP can also be synthesized by inflammatory cells such as eosinophils, macrophages and lymphocytes (Joos and Pauwels, 2001; Groneberg et al., 2006). Other potential sources of tachykinins include the airway epithelium and the ASM (Butler and Heaney, 2007). The biological activity of tachykinins depends on their interaction with three different GPCRs. SP binds to NK₁ receptors, NKA mainly acts via NK₂ receptors, and NKB is most potent at NK₃ receptors (De Swert and Joos, 2006; Groneberg et al., 2006).

Different respiratory functions of tachykinins are due to their different distribution in the respiratory tract. While NK₁ receptors are mainly expressed in the airway epithelium, submucosal glands, and vessels, NK₂ receptors are predominantly localized on the ASM (Groneberg et al., 2004). Therefore NK₁ receptors are involved in the elevation of epithelial and vascular permeability, mucus secretion and vasodilation, whereas NK₂ receptors mediate contraction of the ASM. The role of NK₃ receptors remains poorly understood because until now immunoreactivity for NKB has not been found in the airways. They might be involved in cholinergic transmission (Canning, 1997; Joos and Pauwels, 2001; De Swert and Joos, 2006; Butler and Heaney, 2007). Additionally tachykinins have showed facilitation of ganglionic cholinergic neurotransmission through the activation of both NK₁ and NK₂ receptors in the guinea-pig trachea (Watson et al., 1993). Using selective NK receptor antagonists, two subtypes of NK₂ receptor have been proposed which appear to be species specific. The NK_{2B} subtype mediates contraction of the hamster trachea and NK_{2A} subtype showed selectivity for human bronchi and guinea-pig trachea (Ellis et al., 1993). In human airways NKA is the most potent contractile tachykinin (Ellis et al., 1993). In contrast, in guinea-pig bronchi the contractile response to tachykinins and to EFS is mediated by both NK₁ and NK₂ receptors (Maggi et al., 1991; Heavey et al., 1997; Corboz et al., 2003). Also in the guinea-pig trachea the C-fibre irritants capsaicin- and resiniferatoxin-evoked contractions are mediated through NK₁ and NK₂ receptors (Ellis and Udem, 1994b).

In general, tachykinins are metabolised by enzymatic cleavage to inactive fragments which are removed by peptide transporters (Karlsson, 1994; Groneberg et al., 2006). The degradation is orchestrated by at least two enzymes including angiotensin converting enzyme (ACE) and neutral endopeptidase (NEP). Because ACE is

predominantly expressed in vascular endothelial cells, it breaks down intravascular peptides. In contrast, most of the tachykinins in the airways are inactivated by NEP which is abundant in the airway mucosa and submucosa (Barnes et al., 1991; Groneberg et al., 2006).

To reduce the NEP activity in guinea-pig bronchi and trachea, endopeptidase inhibitors such as thiorphan or phosphoramidon have been used to examine tachykinin receptor mediated contractions to exogenous added tachykinins (Maggi et al., 1991; Ellis et al., 1993) and also to EFS (Heavey et al., 1997).

It has been shown that epithelium removal can enhance the contractile responses to exogenous tachykinins and to endogenous tachykinins released by capsaicin in guinea-pig trachea. Additionally, using NEP and COX inhibitors (indomethacin) tachykinin- and capsaicin-induced contractions were potentiated with the rank order of potency NKA>NKB>SP and producing the same effect as epithelial removal. This suggests that the epithelial damage with defective metabolism of tachykinins may contribute to the neurogenic inflammation (Frossard et al., 1989). However in the presence of intact epithelium, indomethacin potentiated eNANC responses evoked by EFS implying a role for inhibitory prostaglandins (PGE₂) in the modulation of eNANC transmission in guinea-pig bronchi (Johansson-Rydberg et al., 1992).

1.6.3 Neurogenic inflammation

It is generally accepted that the neuropeptides SP, NKA and CGRP are considered to be the major initiators of neurogenic inflammation (Barnes, 1996a).

The mechanism includes orthodromic stimulation of sensory nerve fibre endings by irritants (tobacco smoke, cold air etc.) and inflammatory mediators following transmission into the brainstem. The signal is conducted from the CNS via efferent parasympathetic nerves into intrinsic airway ganglia to induce parasympathetic effects. After the induction of pro-inflammatory neuropeptide gene expression in the sensory ganglia, neuropeptides are antidromically transported back to the peripheral endings, where they are released and propagate the neurogenic inflammation, i.e. sensory fibres may release transmitters also from the same terminal activated by an irritant (Maggi and Meli, 1988; Udem and Carr, 2002; Groneberg et al., 2004).

In many animal models, mostly rodents, the released neuropeptides mimic pathophysiologic features of asthma. This is supported by the knowledge that NKA causes bronchoconstriction and facilitates cholinergic neurotransmission, SP stimulates vasodilation, microvascular leakage (plasma exudation) and mucus secretion from submucosal glands and epithelial goblet cells, and CGRP is a potent vasodilator in the airways (figure 1.6) (Barnes, 1996c; Barnes, 2001).

So far there is insufficient evidence to suggest that neurogenic inflammation is an important component of human asthma. One of the reasons for this statement is the absence of contractile responses to capsaicin and distinct eNANC responses in human airways *in vitro*, i.e. there is inconsistent experimental data between animal models of asthma and humans. In addition, currently available tachykinin receptor antagonists have not shown benefit over inhaled corticosteroid therapy (Butler and Heaney,

2007). However, it is still important to increase our knowledge about the precise role of neurogenic inflammation in asthma or COPD. In order to establish novel approaches to anti-inflammatory therapy and assess the role of sensory neuropeptides in animal models, four ways of modulating neurogenic inflammation should be considered. Inhibition of sensory neuropeptide release, capsaicin depletion studies, the antagonism of tachykinin receptors and inhibition of neuropeptide metabolism (Barnes et al., 1991; Barnes, 2001; Groneberg et al., 2004).

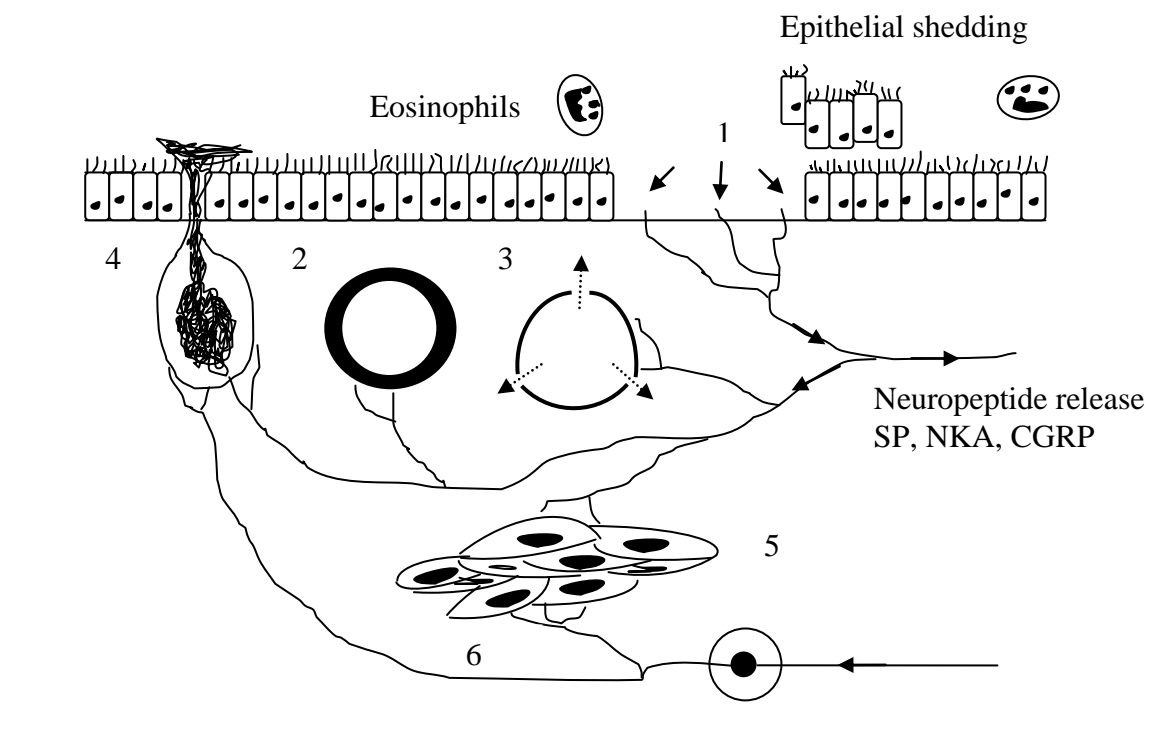

Figure 1.6 Neurogenic inflammation in the airways (Barnes, 2001).

Sensory nerve activation via an axon reflex causes retrograde release of sensory neuropeptides (1). SP produces vasodilation (2), plasma exudation (3) and mucus secretion (4). NKA mediates bronchoconstriction (5) and facilitates cholinergic neurotransmission (6). CGRP causes vasodilatation (2).

1.6.4 Inhibition of sensory neuropeptide release

Sensory nerve activity can be modulated via prejunctional receptors. Vanilloid TRPV₁, bradykinin B₂ and histamine H₁ receptors stimulate neuropeptide release and neurogenic inflammation. In contrast, the inhibition of C-fibres activity can be mediated through adrenergic α_2 , opioid μ , cannabinoid CB₂, dopaminergic D₂, gabaergic GABA_B and histamine H₃ receptors (figure 1.7) (Groneberg et al., 2004). Additionally large conductance Ca²⁺-activated K⁺ channels (Maxi-K⁺ channels) (figure 1.7) have been identified as inhibitors of afferent and efferent sensory nerve function in the guinea-pig because the Maxi-K⁺ channel opener NS1619 inhibited vagal afferent firing of A-fibres, induced by hypertonic saline in the trachea. This compound also inhibited EFS-evoked eNANC responses of isolated bronchi, and finally NS1619 produced reduction of the citric acid-induced cough in conscious guinea-pigs (Fox et al., 1997). The overall effects of cannabinoids on the peripheral efferent function of sensory nerves through CB and vanilloid receptors have been reviewed by Ralevic (2003) and only reports related to this project will be considered further here. The main issue in this context is whether the cannabinoid system could be involved in the neurogenic airway inflammation.

Although Tucker et al. (2001) could not demonstrate a role for the CB receptor on sensory nerves of guinea-pig bronchi using the non-selective CB agonist, CP55940, two studies carried out by Yoshihara et al. (2004, 2005) have clarified the subtype of the CB receptor in the inhibition of sensory nerve function. In the first study they showed that the non-selective cannabinoid agonist WIN55212-2 (0.01-10 μ M) and the selective CB₂ agonist JWH133 (0.1-100 μ M) concentration-dependently inhibited EFS-evoked contraction in a CB₂ selective antagonist, SR144528-sensitive manner

(10 nM) whereas the selective CB₁ antagonist, SR141716A (10 nM) had no effect. Moreover, WIN55212-2 inhibited capsaicin-induced bronchial smooth muscle contraction, but not the NKA-induced contraction. Both agonists, WIN55212-2 (3 μM) and JWH133 (10 μM) blocked the capsaicin-induced release of SP-like immunoreactivity from guinea-pig airways. The inhibitory effect of WIN55212-2 on eNANC contraction was reduced by iberiotoxin and charybdotoxin (Maxi-K⁺ channel blockers) while the Maxi-K⁺ channel opener, NS1619, inhibited NANC contractile responses to EFS. This observation suggests that WIN55212-2 inhibits the activation of C-fibres via CB₂ receptors and Maxi-K⁺ channels in guinea-pig bronchi (Yoshihara et al., 2004).

The second study investigated the role of endogenous cannabinoids, AEA and PEA in the neurogenic inflammation of guinea-pig bronchi. PEA is an endogenous fatty acid amide analogue of AEA. There is evidence for its protective, anti-inflammatory and analgesic properties in animal models. The mechanism of its action does not involve activation of CB₁ and/or CB₂ receptors, but it may act as an “entourage” compound potentiating the effect of endocannabinoids. However, new evidence shows that PEA inactivation can also occur independently from that of AEA and 2-AG employing a novel enzyme, N-acyl ethanolamine-hydrolyzing acid amidase (NAAA, breaks down PEA to two inactive products, palmitic acid and ethanolamine). This mechanism needs further investigation (Lambert and Di Marzo, 1999; Vandevorde and Lambert, 2005; Mackie and Stella, 2006; Re et al., 2007).

Experimentation with AEA (0.03-30 μM) and PEA (0.003-3 μM) has suggested that their action is mediated via activation of CB₂ receptors and opening of Maxi-K⁺ channels, since SR144528 reduced the inhibitory effect of endogenous agonists but SR141716A had no effect. Inhibitory effects of agonists were also reduced by the

pretreatment with iberiotoxin and charybdotoxin. Additionally the capsaicin-induced SP-like immunoreactivity was significantly reduced by both cannabinoid agonists indicating the inhibition of neuropeptide release from C-fibre endings in guinea-pig airways (Yoshihara et al., 2005). These findings lead to the conclusion that CB₂ receptors might play a role in cannabinoid-induced inhibition of sensory nerve function in guinea-pig bronchi.

There is mounting evidence for CB receptor-independent action of different cannabinoid ligands, e.g. vanilloid receptors can mediate cannabinoid-evoked responses. The next chapter will give a brief overview of the vanilloid receptor and its interaction with the endocannabinoid AEA.

1.6.5 Activation of sensory neuropeptide release and vanilloid receptors

In guinea-pig airways, capsaicin has a unique excitatory action on sensory C-fibres. Firstly, this action can lead to central reflexes such as cough (Maggi and Meli, 1988; Lalloo et al., 1995) and secondly, the release of tachykinins from peripheral terminals of C-fibres mediates the ASM contraction (Maggi et al., 1991; Ellis and Udem, 1994a).

On the cellular level capsaicin activates the vanilloid receptor-1 which is a Ca²⁺-permeable, non-selective cation channel. The receptor has been cloned from rat sensory neurons in 1997 (Bevan and Szolcsányi, 1990; Caterina et al., 1997) and can also be stimulated by resiniferatoxin (a potent capsaicin analog from Euphorbia plants), noxious heat (>43°C) and protons suggesting that the receptor can mediate both thermal and chemical pain (Caterina et al., 1997; Szallasi and Blumberg, 1999). In 2002 the receptor was reclassified to the transient receptor potential (TRP) family,

and named transient receptor potential vanilloid-1 (TRPV₁) (Gunthorpe et al., 2002). Recent studies of functional expression and biological functions of the TRPV₁ receptor in the airways led drug discovery research to develop synthetic TRPV₁ antagonists with the potential indication against asthma (Geppetti et al., 2006; Jia and Lee, 2007; Gunthorpe and Szallasi, 2008).

The first study considering the possibility that the endocannabinoid AEA might act at the TRPV₁ has been reported by Zygmunt et al. (1999). The reason for this hypothesis was the structural similarity of capsaicin and AEA both possessing an amide bond and aliphatic side chain. The vasorelaxant activity of AEA has been shown to be mediated via CGRP release from vascular sensory nerves in rat hepatic and small mesenteric arteries and guinea-pig basilar artery. This proposed action of AEA through the TRPV₁ has been supported by the failure of other endocannabinoids (2-AG and PEA) and additionally more potent synthetic cannabinoids (HU210, CP55940, WIN55212-2) to mimic the vasodilation of AEA. The CB₁ receptor blocker SR141716A had no effect which was in contrast to the inhibitory effect of the selective CGRP-receptor antagonist 8-37 CGRP on the relaxation evoked by AEA (Zygmunt et al., 1999).

The full agonistic activity of AEA at the human TRPV₁ (hTRPV₁) has been characterized in HEK293 cells transfected with the hTRPV₁. Capsaicin and AEA showed similar kinetic (elevation of the intracellular Ca²⁺) and electrophysiological (activation of an inward current) properties. Furthermore, the AEA-induced response was inhibited by the TRPV₁ antagonist capsazepine but not by CB antagonists AM630 or AM281 (Smart et al., 2000).

However, the sensitivity of AEA for the TRPV₁ in transfected human cells might be different from the activity of this endocannabinoid at the TRPV₁ in guinea-pig airways. Despite the immunohistochemical evidence of TRPV₁ immunoreactive

axons in close proximity to smooth muscle bundles in guinea-pig airways (Watanabe et al., 2005), AEA (1-100 μ M) could not produce the same maximal contractile response as capsaicin (0.01-10 μ M) in isolated guinea-pig bronchi, possibly indicating its partial agonism (Tucker et al., 2001). While capsazepine at 10 μ M (Bevan et al., 1992) significantly attenuated the AEA-evoked responses, the NK₁ selective antagonist, SR140333 at 1 μ M (Calassi et al., 1993; Emonds-Alt et al., 1993) and the selective CB₁ antagonist, SR141716A (1 μ M) did not alter the effect of AEA (Tucker et al., 2001). The NK₂ antagonist, SR48968 at 100 nM (Emonds-Alt et al., 1992) abolished the modest contractile effect of AEA which is further evidence that this substance activates not only the TRPV₁ but also the NK₂ receptor in the guinea-pig bronchial preparation (Tucker et al., 2001). Inhibition of intracellular AEA hydrolysis by PMSF (50 μ M) did not alter the AEA-induced response (Tucker et al., 2001; Andersson et al., 2002) but a significant increase has been observed in the presence of the NEP inhibitor, tiorphan (10 μ M). This finding seemed to rule out the possibility of active metabolism of AEA by FAAH in the guinea-pig tissue but implicates the release of neuropeptides in its contractile action (Tucker et al., 2001). Contrary to this study, Craib et al. (2001) have demonstrated a significant increase of AEA-elicited bronchoconstriction using PMSF (20 μ M) as an amidase inhibitor, i.e. the inactivation of the endocannabinoid signalling by the FAAH is questionable in the isolated guinea-pig bronchi. Interestingly, the more specific and more potent FAAH inhibitor, URB597 (Tarzia et al., 2003; Fegley et al., 2005) also appeared to act differently in different tissues. While in rat isolated small mesenteric arteries, URB597 potentiated the relaxation evoked by AEA (Ho and Randall, 2007), in rat isolated urinary bladder, the same compound at the same concentration attenuated the AEA-induced contraction of the muscle strips (Saitoh et al., 2007). Pertwee's group has extended

the former investigation using lipoxygenase inhibitors such as 5,8,11,14-eicosatetraenoic acid (ETYA, 10 μ M) and 5,8,11-eicosatrienoic acid (ETI, 20 μ M) (Craib et al., 2001). They suggested that the AEA-induced guinea-pig bronchoconstriction via activation of the TRPV₁ can involve lipoxygenase metabolites of AEA such as hydroperoxyderivatives of arachidonic acid and leukotriene A₄ (Craib et al., 2001). This hypothesis originated from a report published by Hwang et al. (2000) who showed that products of 5-LO directly activate the TRPV₁ in sensory neurons from rat dorsal root ganglions and in transfected HEK293 cells. On the other hand, products of COX, prostaglandins (PGE₂, PGD₂, PGI₂) failed to activate the ion channel (Hwang et al., 2000).

The non-pungent analog of capsaicin, olvanil has not showed the ability to evoke nor to desensitize TRPV₁-mediated responses in the same manner as capsaicin or resiniferatoxin within guinea-pig airways (Stebbins et al., 2003). Furthermore, a contrast has been observed also in the non-efficacy of olvanil to stimulate tachykinin release and to elicit action potential discharge in capsaicin-sensitive C-fibres, showing different activities of TRPV₁ agonists in different experimental systems (Stebbins et al., 2003).

The next chapter describes few advances made, contributing to the knowledge of potential role of cannabinoids in the airways.

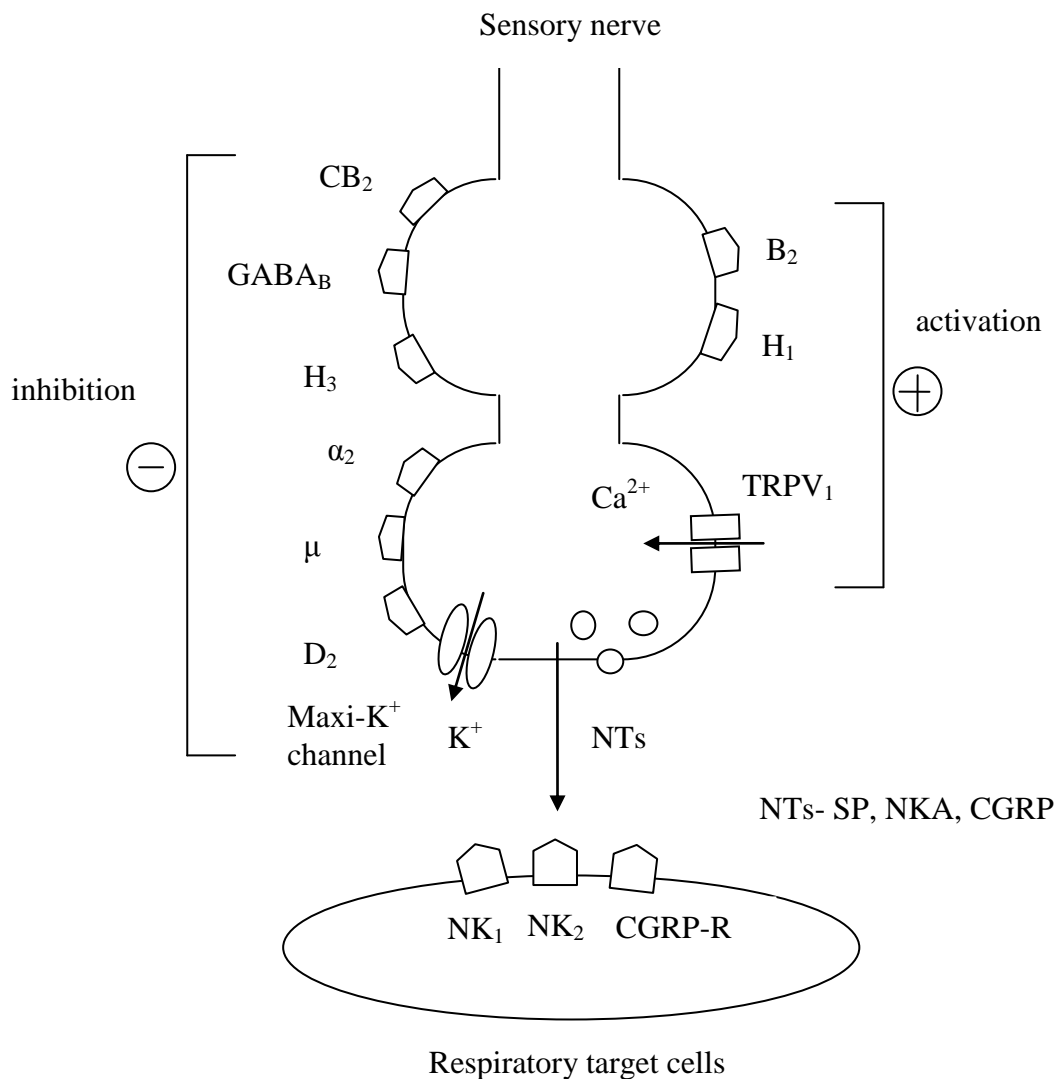

Figure 1.7 Modulation of sensory nerve function (modified from Groneberg et al., 2004).

The sensory nerve-mediated airway effects are induced via antidromic release of pro-inflammatory neuropeptides such as SP, NKA and CGRP and their postsynaptic receptors NK₁, NK₂ and CGRP-R. Prejunctionally localized vanilloid TRPV₁, bradykinin B₂ and histamine H₁ receptors can stimulate these effects. In contrast, the inhibition of C-fibres activity can be mediated through presynaptic adrenergic α₂, opioid μ, cannabinoid CB₂, dopaminergic D₂, gabergic B, and histamine H₃ receptors, and Maxi-K⁺ channels.

1.6.6 Cannabinoids and the airways

The first report describing the *in vivo* pulmonary responses to AEA brought more negative than positive data (Stengel et al., 1998). AEA applied intravenously did not produce any changes of measured dynamic compliance or total pulmonary resistance in anaesthetized guinea-pigs. Also, AEA was ineffective in reversing the increase in airway resistance produced by inhaled A23187, the divalent cationic ionophore. In contrast, AEA was effective in reduction of A23187-induced inflammation (epithelial injury and pulmonary leukocytosis). The authors concluded that AEA does not possess any bronchodilator action and excludes its direct effect on the ASM tone (Stengel et al., 1998).

Later studies showed that the endocannabinoid AEA is synthesized in response to Ca^{2+} stimulation in the rat and guinea-pig lung tissue and produces dual effects on the bronchial response (Calignano et al., 2000). Firstly, there is strong inhibition of capsaicin-evoked bronchospasm (increase of airway resistance) and cough. Secondly, bronchoconstriction occurs in vagotomized rodents. The former effect was blocked by the CB_1 antagonist, SR141716A but not by the CB_2 antagonist. This shows mediation by CB_1 receptors which have been detected on axon terminals of airway nerves in rat lungs in close proximity to bronchial and bronchiolar smooth muscle cells (Calignano et al., 2000). The authors suggested that the endocannabinoids may play a bidirectional role in regulating the airway smooth muscle tone, causing bronchorelaxation when the smooth muscle is constricted and bronchoconstriction when the muscle is relaxed (Calignano et al., 2000). This proposed endocannabinoid-mediated control of airway responsiveness triggered further investigations which focused on a possible neuromodulatory role of cannabinoids in the airways.

The first study related to cholinergic neurotransmission has been performed in guinea-pig trachea. Spicuzza et al. (2000) suggested a CB₂ receptor-mediated inhibition of ACh release (from postganglionic parasympathetic nerves) induced by the non-selective cannabinoid agonist CP55940 and AEA (both at 1 μM), although the effect was not confirmed by using CB₂ selective agonists or antagonists. Intriguingly, CP55940 (1 μM) had no effect on EFS-induced or ACh-induced cholinergic contractile responses, and did not relax carbachol-precontracted tissue. The failure of rimonabant (1 μM) to reverse the inhibitory effect of CP55940 on EFS-evoked [³H]-ACh and to affect ACh release ruled out the involvement of prejunctional CB₁ receptors in the bioassay. This is consistent with the finding that there was no detectable specific binding of [³H]-CP55940 in tracheal homogenates (Spicuzza et al., 2000). Nevertheless, in the same tissue other authors reported that neither CB₁ nor CB₂ receptors mediate modulation of ACh release but TRPV₁-like receptors can probably inhibit cholinergically-mediated responses to EFS (Nieri et al., 2003). The reason for this conclusion was the statistically significant concentration-dependent (0.1-100 μM) inhibitory effect of the stable AEA analog, R-(+)-methanandamide which was not blocked by rimonabant (1 μM) but its effect was antagonized by the TRPV₁ antagonist, capsazepine (1 μM). Additionally the non-selective cannabinoid agonist, WIN55212-2 and the selective CB₂ agonist JWH015 (both at 0.01-10 μM) exerted only minor effects on the cholinergic neurotransmission, whereas the TRPV₁ agonist, capsaicin (0.03-0.06 μM) unexpectedly inhibited cholinergic responses evoked by EFS, suggesting TRPV₁-like receptor mediated action (Nieri et al., 2003). At the postjunctional level none of the cannabinoid agonists investigated, 2-AG, CP55940, R-(+)-methanandamide, WIN55212-2, HU-210 and JWH015 evoked any contractions of guinea-pig trachea, bronchi, lung parenchymal strips or influenced

tracheal contractions to exogenous ACh (Spicuzza et al., 2000; Tucker et al., 2001; Andersson et al., 2002; Nieri et al., 2003).

The ultrastructural evidence of CB₁ receptors on NPY-positive sympathetic nerve terminals (varicosities) with prejunctional inhibitory α_2 -adrenoceptors in the guinea-pig lung (Calignano et al., 2000) led Vizi et al. (2001) to investigate the effects of the CB₁ receptor activation on NA release in the presence and absence of α_2 -adrenoceptor-mediated negative feedback control on NA release. In this study the non-selective cannabinoid agonist, WIN55212-2 concentration-dependently (0.01-0.1 μ M) reduced the release of [³H]-NA evoked by EFS in a CB₁ receptor antagonist-sensitive manner (rimonabant at 1 μ M completely prevented the action of WIN55212-2). In the presence of BRL44408 (α_{2B} -adrenoceptor antagonist) and prazosin (α_1 - and α_{2B} -adrenoceptor antagonist), the release of labelled NA was increased, suggesting that the α_{2B} -subtype negatively modulates the NA release from guinea-pig bronchi. Prevention of the α_2 -adrenoceptor-mediated tonic control (using the α_2 -adrenoceptor antagonist, CH38083) revealed more potent inhibitory effect of WIN55212-2 (mediated via activation of CB₁ receptors) on [³H]-NA release. Therefore, the locally released AEA in response to receptor activation in the lung (Calignano et al., 2000) might inhibit the NA-mediated relaxation i.e. produce bronchospasm (Vizi et al., 2001).

The effect of WIN55212-2 has also been studied on the NANC system by two different research groups. First, Yoshihara et al. (2004) demonstrated the ability of this cannabinoid to modify the neural activity of the excitatory NANC system in guinea-pig bronchi. The study has been described in the section 1.6.4. Second, Nieri et al. (2003) assessed the effect of WIN55212-2 on NANC-mediated relaxation in the guinea-pig trachea. They showed that WIN55212-2 (10 μ M) but not R-(+)-

methanandamide or JWH015 significantly enhanced the electrically induced inhibitory NANC responses and this effect was not influenced by the selective CB₁/CB₂ antagonists SR141716A/SR144528. The WIN55212-2-induced relaxation to EFS was blocked by the NO synthase inhibitor, L-N^G-nitro-arginine methyl ester (L-NAME), but maintained in the presence of α -chymotrypsin (a peptidase degrading VIP). The NO-generating agent, sodium nitroprusside induced relaxation in histamine precontracted tissue which was not affected in the presence of WIN55212-2, excluding its effect on NO-induced relaxation at the postsynaptic level. Therefore WIN55212-2 at a high concentration potentiated the relaxant response through a cannabinoid receptor-independent mechanism involving NO-mediated component (Nieri et al., 2003).

Disappointingly, these experimental findings did not provide further implications for clinical research. Given the important role of mast cells in asthma pathology, the next chapters provide an insight into mast cell biology and future aspects promising new clinical applications for drugs.

1.7 Mast cells

Although mast cells were discovered more than 100 years ago, the mechanisms which regulate their function remain an enigma (Bachelet and Levi-Schaffer, 2007). In 1879, Paul Ehrlich described them as cells with large numbers of secretory membrane-bound granules (Holgate and Kay, 1985). Mast cells are functionally similar to basophil leukocytes which have characteristic bilobed nuclei. Both mast cells and basophils are considered crucial cells for an allergic reaction, they originate from hematopoietic precursors, CD34⁺ progenitors (Austen and Boyce, 2001; Gurish and Austen, 2001). Basophils generally mature in the bone marrow, circulate in mature form and are subsequently moved into different inflammatory tissues. In contrast, mast cells migrate to peripheral tissues (connective, mucosal tissue and neural tissue), where they terminate their differentiation and participate in inflammatory and immunologic reactions as matured cells (figure 1.8) (Busse and Holgate, 1995; Williams and Galli, 2000; Gurish and Austen, 2001). The essential factor in the development of mast cell lineage is the interaction of a growth factor, stem cell factor (SCF) and its receptor, c-kit, expressed on the surface of mast cells (figure 1.8) (Williams and Galli, 2000; Austen and Boyce, 2001). Mast cell phenotype is greatly influenced by T-lymphocyte function. While the constitutive mast cell development is T cell-independent, the reactive mast cell development is modulated by T cells. Thus under normal conditions, SCF ligand and the membrane-associated receptor tyrosine kinase c-kit ensure basal population of mature mast cells (Boyce, 2003). In addition, they can mature under the influence of locally derived growth factors. For instance, after repeated inhalation of allergen at low-dose, a local increase in the number of mast cells has been attributed to the enhanced expression of nerve

growth factor (NGF) mRNA in bronchial biopsies of asymptomatic asthmatics. In the same study, the positive expression of tyrosine kinase receptor (TrkA) for NGF on the membrane of infiltrated bronchial mast cells supports the function of NGF as a promoter of growth and survival of mast cells (Kassel et al., 2001).

It is therefore likely that in asthma, T cells not only control mast cell numbers but can also alter several mast cell effector properties (Boyce, 2003). Mast cell effector functions in asthma result in the release of mast cell mediators (Holgate and Kay, 1985; Graziano, 1988; Williams and Galli, 2000; Bloemen et al., 2007).

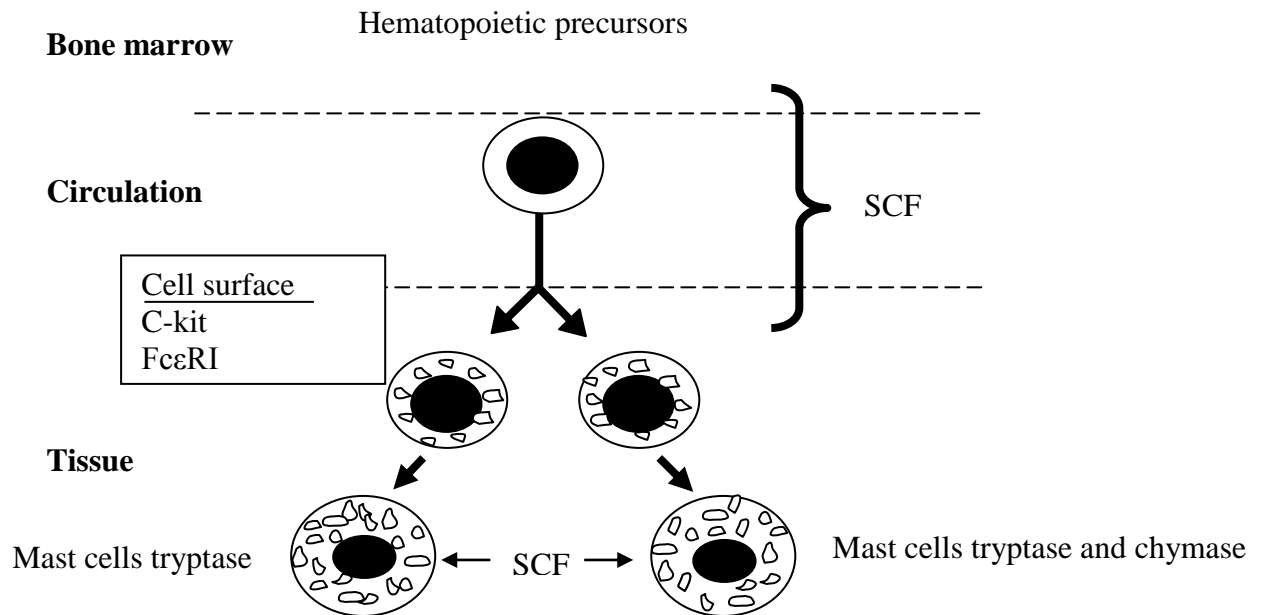

Figure 1.8 Development of human mast cells (Busse and Holgate, 1995).

Mast cell progenitors arise in the bone marrow, circulate through the vasculature and move into tissues to complete their maturation.

1.7.1 Mast cell mediators

Mediators produced by mast cells can be divided into preformed mediators, newly synthesized mediators, and cytokines. The release of mast cell mediators is due to their activation. There are three types of mast cell activation, firstly IgE-dependent (Gilfillan and Tkaczyk, 2006), secondly IgE-independent, related to bacterial or viral infection (Boyce, 2003), and thirdly in response to certain drugs such as, compound 48/80, ionomycin and opioids (De Filippis et al., 2008). IgE-dependent mast cell activation occurs when IgE bound to the high-affinity IgE Fc receptor (FcεRI) on mast cells is cross-linked by allergens triggering mast cell degranulation (Gilfillan and Tkaczyk, 2006). Also, ion channels play a critical role in mast cell activation. While K⁺ and Cl⁻ channels may modulate the secretion of mediators, the essential requirement for the IgE-dependent mediator release is the influx of extracellular Ca²⁺ (Bradding, 2005; Bradding, 2008).

The preformed mediators are stored in the cytoplasmic granules, and on activation they are secreted into the extracellular space within minutes. Major granule constituents include histamine, serine proteases (tryptase, chymase, carboxypeptidase), proteoglycans (heparin, chondroitin sulphate E), and exoglycosidases (Holgate and Kay, 1985; Graziano, 1988; Williams and Galli, 2000; Bloemen et al., 2007). On the basis of content, mast cells are subdivided into mast cells tryptase and mast cells tryptase and chymase. In human lung the mast cell tryptase is the predominant mast cell type (Robinson, 2004).

The major granule mediator, histamine, has multiple effects on airway function which are mediated via histamine receptors, H₁, H₂, H₃ and H₄. Histamine effects relevant to asthma are predominantly mediated through H₁ receptors which are present on the

smooth muscle, secretory glands, endothelial and epithelial cells, and sensory nerves. The activation of H₁ receptors results in bronchoconstriction, plasma extravasation, vasodilation, mucus secretion and enhancement of cholinergic bronchoconstriction. H₂ receptor activation produces bronchodilation and mucus secretion. H₃ receptors in cholinergic ganglia, on postsynaptic cholinergic and sensory nerve terminals cause inhibition of the release of acetylcholine and neuropeptides. In contrast, H₁ receptors also expressed on the sensory nerve terminals, can stimulate neuropeptide release, contributing to neurogenic inflammation (Chand and Sofia, 1995; Barnes et al., 1998; Belvisi et al., 2004). Recently, the H₄ receptor was identified on eosinophils, T cells, dendritic cells, basophils and mast cells. In mice, the combination of genetic and pharmacological ablation of the H₄ function has showed diminished allergic responses, such as reduced eosinophilic and lymphocytic inflammation, decreased secretion of T cell cytokines (IL-4, IL-5, IL-13, IL-6, IL-17) and IgE production, indicating an important role of H₄ receptors in asthma (Dunford et al., 2006). In a migration assay of human mast cells, the selective H₄ antagonist, JNJ, abolished the synergistic effect of histamine and CXCL12, possible mast cell chemoattractants, suggesting that H₄ receptor might mediate the recruitment of mast cell precursors in tissues constitutively expressing CXCL12 (Godot et al., 2007).

Newly generated lipid mediators are the cyclooxygenase (COX) and 5-lipoxygenase (5-LO) metabolites of arachidonic acid, prostaglandins (PGs) and leukotrienes (LTs), respectively. They contribute to asthmatic symptoms by acting through GPCRs (Bloemen et al., 2007). The principal COX product is PGD₂ which elicits bronchoconstriction, tissue oedema and mucus secretion (Boyce, 2003; Bradding, 2007), and also it can induce eosinophil accumulation (Pettipher, 2008; Whelan, 2009). From the 5-LO products, cysteinyl LTs (LTC₄, LTD₄, LTE₄) and LTB₄ have

an important pathophysiological role in asthma. Cysteinyl LTs (cysLTs) acting through at least 2 receptor subtypes, cysLT₁ and cysLT₂, are potent bronchoconstrictors, and they can increase airway hyper-responsiveness, mucus secretion and capillary permeability. Furthermore, cysLTs can cause eosinophil recruitment and activation, and decrease eosinophil apoptosis. Although LTB₄ has no bronchoconstrictor effect in healthy or asthmatic subjects, it can contribute to airway hyper-responsiveness, producing local oedema and mucus hypersecretion (Montuschi et al., 2007).

Mast cells represent a potential source of multifunctional cytokines and growth factors which regulate IgE synthesis (IL-4), the development of eosinophilic inflammation [IL-3, IL-5, GM-CSF (granulocyte/macrophage colony-stimulating factor)] and mucus secretion (IL-6). Other cytokines secreted by mast cells include IL-8 (neutrophil chemotaxis), IL-16 (T cell chemotaxis), the profibrogenic cytokines, tumor growth factor (TGF)- β and basic fibroblast growth factor (bFGF). Moreover, they produce chemokines, such as macrophage inflammatory protein (MIP)-1 α (stimulation of histamine release from mast cells and basophils), monocyte chemotactic protein (MCP)-1, and CCL11 [(eotaxin), leukocyte attraction]. The major cytokine, strongly implicated in the pathogenesis of asthma, TNF- α is available for immediate release from mast cells. It upregulates endothelial and epithelial adhesion molecules and increases airway hyper-responsiveness (Bradding and Holgate, 1999; Page et al., 2001; Bradding et al., 2006; Bloemen et al., 2007).

On one hand, classic mast cell autacoid mediators, such as histamine, LTC₄, PGD₂, are all potent agonists for ASM contraction. On the other hand, these classic mast cell autacoid mediators and other mediators (IL-6, IL-13, TNF- α , tryptase and chymase) are important for the mucous gland hyperplasia and the mucus gland secretion. In

addition, mast cell secretion within the airway epithelium promotes epithelial denudation activation and permeability (Bradding, 2003; Bradding et al., 2006). Taken together, mast cells and their products play an important role in the pathophysiology of asthma and the study of mast cell function definitely deserves scientific attention. There is growing evidence about the possible relevance of mast cell-airway smooth muscle interaction in the asthma phenotype.

1.7.2 Mast cell-airway smooth muscle interaction

On the basis of a study by Brightling et al. (2003) the asthma research refocuses the attention to mast cells that evidently might contribute to the pathophysiology of this disease. The finding of two key differences between the pathology of asthma and eosinophilic bronchitis (EB) open novel avenues in the field and suggested that disordered airway function in asthma is due to a mast cell smooth muscle myositis. The first is the elevated concentration of IL-13 in sputum of asthmatics compared with EB and normal controls. Additionally, in asthmatic bronchial biopsies the eosinophil expression of IL-13 was higher in comparison to normal subjects and subjects with EB (Berry et al., 2004). The most striking difference is the mast cell microlocalization within asthmatic ASM. The majority of these mast cells were of tryptase and chymase phenotype, expressing IL-4 and IL-13 but not IL-5 (Brightling et al., 2002; Brightling et al., 2003). In contrast, there were no mast cells in bronchial smooth muscle bundles in patients with EB or normal individuals. Interestingly, there was no difference between asthma and EB in terms of T cell and eosinophil infiltration. The negative correlation of the ASM mast cell number and the degree of airway hyper-responsiveness suggests that the mast cell microlocalization is a critical

event in the development of the asthmatic phenotype (Brightling et al., 2002; Brightling et al., 2003).

Mast cell infiltration of the ASM in asthma will facilitate specific interactions between these cells and smooth muscle cells. It is hypothesized that the initiation of mast cell recruitment stems from the ASM which can release cytokines, growth factors, and chemoattractants for mast cells or their progenitors (IL-6, GM-CSF, CCL11, TGF- β). The propagation of disordered smooth muscle function (hypertrophy and hyperplasia, bronchial hyper-responsiveness) might be due to mast cell activation in response to exogenous stimuli (allergen, viruses) or local factors (SCF, cell-cell contact) which is undoubtedly a complex process. Subsequently, products of degranulated mast cells can directly constrict the ASM (histamine, LTs, PGD₂), potentiate their constrictor response (IL-4, IL-13, tryptase, TNF- α), and cause smooth muscle proliferation and airway remodelling (neutral proteases, TGF- β , bFGF). Thus there could be a positive feedback loop between mast cell activation and disordered smooth muscle physiology, leading to amplification of the airway inflammation and bronchial hyper-responsiveness (Bradding, 2003; Robinson, 2004; Bradding et al., 2006).

Undoubtedly, further understanding of mast cell biology can offer novel approaches to the treatment of asthma. However, to date, the ovalbumin-sensitized and challenged guinea-pig has been widely used as a reliable model of human asthma. As mentioned in the chapter 1.5, an allergen exposure in individuals with allergic asthma results in an EAR followed by a LAR (Cockcroft, 1983). Similarly, in sensitized guinea-pigs, an antigen challenge can initiate an early bronchoconstrictor response due to release of pharmacological mediators (histamine, tachykinins, LTs and prostaglandins) from cells such as macrophages and mast cells which act on smooth muscle to cause

bronchospasm. The late bronchoconstrictor response is associated with infiltration of key inflammatory cells into the airways, their activation and subsequent chronic inflammation (Smith and Johnson, 2005; Smith and Broadley, 2007). Mast cell-driven antigen-induced guinea-pig bronchial contraction mimicking the early allergic airway response in humans offers a common and well-established model to characterize a potential drug and its relevance in bronchial asthma.

1.7.3 Mast cells and anti-inflammatory medication

The drugs sodium cromoglycate and nedocromil sodium, collectively called chromones, were believed to work as mast cell stabilisers. Prevention of the EAR and LAR to inhaled allergens and inhibition of the asthmatic attack to different indirect stimuli are the major clinical effects of chromones. Despite their great therapeutic value and safety, there is a limitation in their clinical use (Howell and Altounyan, 1967; Woolcock, 1995; Barnes, 2006b). Later it became clear that their effects are not specific and apart from mast cells (Wells et al., 1986; Leung et al., 1988) they can also work on eosinophils, epithelial cells and sensory nerves (Alton et al., 1996; Norris and Alton, 1996). Although chromones have been replaced by inhaled corticosteroids, they remain a challenging therapy (Barnes, 2006b). The evidence of chloride transport blockade in a rat mast cell line suggested a novel mechanism of action for chromones (Norris and Alton, 1996) but disappointingly it has been found that they are only weak antagonists of secretion from a human mast cell line (Bradding, 2005). Noteworthy is to highlight the species-dependent heterogeneity between mast cell phenotypes and special caution is needed in data interpretation and drawing conclusions. The novel strategies are in targeting cell surface molecules on

mast cells (c-kit or SCF, CD63), in the inhibition of FcεRI signalling [inactivation of spleen tyrosine kinase (SYK)] or in the identification of mast cell ion channels and their precise function (figure 1.9) (Bradding, 2005; Bradding, 2008; Holgate and Polosa, 2008).

From other treatments, antihistamines have also been disappointing (Van Ganse et al., 1997). However, H₄ antagonists might be promising in the treatment of allergic diseases (Godot et al., 2007). The only mediator antagonists that are currently used in asthma therapy are the antileukotrienes, which block cysLT₁ receptors. CysLT₁ receptor antagonists inhibit EAR and LAR induced by allergen inhalation (Roquet et al., 1997) and they improve symptoms in patients with perennial asthma and seasonal allergic rhinitis. In combination with inhaled glucocorticosteroids, CysLT₁ receptor antagonists enable a reduction in the dose of inhaled glucocorticosteroids while maintaining similar therapeutic response (Montuschi et al., 2007). From numerous 5-LO inhibitors, only zileuton passed clinical trials. The compliance was increased by combination therapy of inhaled glucocorticosteroids and inhaled long-lasting β₂-agonists (Holgate and Polosa, 2008).

The interest in cytokines as targets for new asthma therapies was reflected by clinical trials of the inhibition of two crucial cytokines implicated in chronic inflammation. However, in asthmatic patients the inhibition of IL-4 and IL-5 did not provide any clinical benefit (Barnes, 2006b). Nevertheless, particular interest in blocking IL-13 and IL-9 is still continuing (Padilla et al., 2005; Holgate and Polosa, 2008). Anti-TNF-α therapy might be of clinical significance in subjects with severe asthma (Howarth et al., 2005). Administration of the soluble TNF-α P75 receptor IgG1Fc fusion protein Etanercept (TNF receptor blocker) for 10 weeks improved quality of

life, lung function, and bronchial hyper-responsiveness of patients with severe asthma (Berry et al., 2006).

More specifically, anti-IgE treatment (figure 1.9) with omalizumab (antibody) is shown to reduce the serum level of free IgE by forming omalizumab-IgE complexes whereby it blocks the interaction between IgE and effector cells. It can down-regulate the expression of IgE receptors on circulating basophils and dendritic cells. In addition to the inhibition of mast cells, there was also a profound reduction in bronchial eosinophils, T cells and B cells upon omalizumab administration. The best responders to anti-IgE therapy are patients with severe persistent allergic asthma who are poorly controlled despite high-dose inhaled corticosteroid therapy (Holgate et al., 2006; Fox, 2007; Holgate and Polosa, 2008; Singh and Kraft, 2008).

Taken together, the development of potent and specific inhibitors of mast cell function might shed a new light on our understanding of the complexity of asthma and should offer a novel approach to the treatment of this disease. Since the discovery of the endocannabinoid system, significant advances have been made within the cannabinoid field. Particular interest was bestowed on the possible role of cannabinoids in the mast cell function.

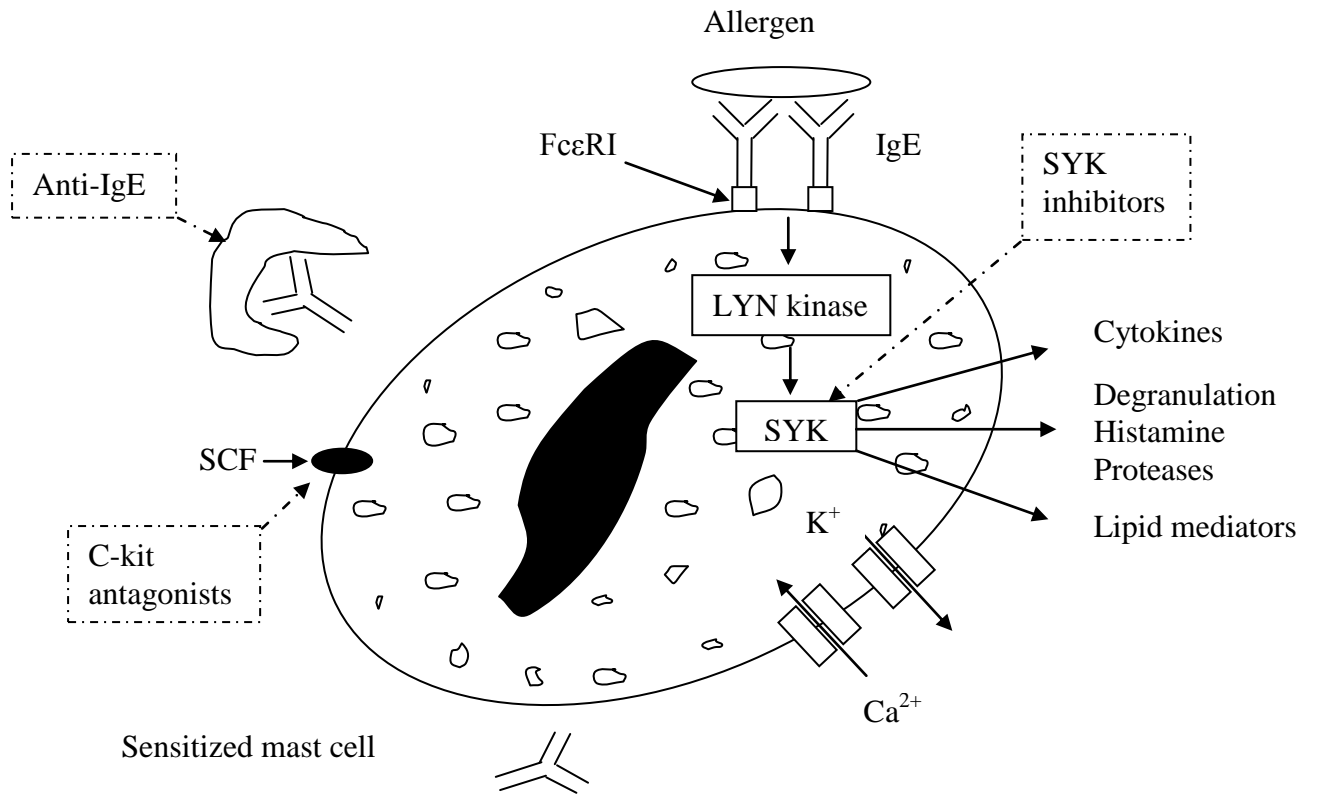

Figure 1.9 Therapeutic strategies of the inhibition of mast cell function in asthma (modified from Barnes, 2006b and Bradding, 2008).

Mast cell activation might be inhibited by blocking IgE binding to the FcεRI, by inhibiting c-kit which is activated by SCF, by inhibiting SYK signalling or by modulating ion channel function.

1.7.4 Mast cells and cannabinoids

Although immune cells (B cells, natural killer cells, monocytes, neutrophils, T cells) express both CB₁ and CB₂ receptors, there is some controversy as to whether mast cells express CB receptors or not and whether they mediate the actions of cannabinoid ligands (Klein et al., 2003; Cabral and Staab, 2005; Croxford and Yamamura, 2005).

The first study which has demonstrated the expression of binding sites for cannabinoids and the gene encoding the CB₂ receptor in rat basophilic leukemia cells (RBL-2H3) and rat peritoneal mast cells was published by an Italian group (Facci et al., 1995). Additionally, they observed that PEA but not AEA inhibited [³H]-serotonin release from RBL-2H3 cells. The authors concluded that mast cell CB₂ receptors might down-modulate mast cell activation, and thus inflammation (Facci et al., 1995). In support of the observation that rat peritoneal mast cells express CB₂ mRNA, Bueb et al. (2001) assessed the capacity of natural, endogenous and synthetic cannabinoids (Δ^9 -THC, Δ^8 -THC, PEA and their derivatives, AEA, WIN55212-2, SR141716A and SR144528) to induce histamine release from these cells. They showed that only Δ^9 -THC and Δ^8 -THC (10-100 μ M) were able to release histamine from rat peritoneal mast cells in a CB receptor-independent manner, indicating non-specific effects of cannabinoids (Bueb et al., 2001). Similarly, the presence of functional CB₁ and CB₂ receptors in rat peritoneal mast cells is not supported by a study from Lau and Chow. They demonstrated that AEA only at concentrations higher than 1 μ M significantly induced histamine release but that, anti-IgE induced histamine release was not affected by AEA treatment (Lau and Chow, 2003). In contrast, the synthetic cannabinoids, WIN55212-2 and HU-210 (both at 10 μ M) enhanced anti-IgE-induced

histamine release. All these effects of cannabinoids were not reversed by CB₁ and CB₂ antagonists, postulating that cannabinoids might not influence mast cell activation through CB receptors (Lau and Chow, 2003).

Noteworthy is the observation that RBL-2H3 cells co-express CB₁ and CB₂ receptors at the mRNA and protein levels and that the application of CB₂-selective and non-selective CB₁/CB₂ agonists can activate an extracellular signal-regulated kinase, and activation of this signalling can impact multiple transcription factor genes. CB₁-mediated pathways have been shown to be linked to the suppression of serotonin release (Samson et al., 2003).

In the same model of RBL-2H3 cells, the long-term ligation of CB₁ leads to superactivation of AC (transcriptional up-regulation of AC isoforms) followed by enhancement of cAMP levels. In contrast, CB₂ ligation causes the opposite, suppression of cAMP levels. The finding of the CB₁-mediated cAMP elevation might contribute to the possible mechanism by which cannabinoids may suppress mast cell activation, thus reduce the secretion of mast cell mediators and reporting their anti-inflammatory potential (Small-Howard et al., 2005).

In RBL-2H3 cells, mast cell activation has been reported to be triggered by THC and CBD, the effect of two natural cannabinoids as opposed to the action of two synthetic cannabinoids, WIN55212-2 and CP55940 (Del Giudice et al., 2007). The immunosuppressive and anti-inflammatory properties of CBD are well established (Zimmerman et al., 1977; Baczynsky and Zimmerman, 1983; Srivastava et al., 1998; Costa et al., 2004; Sacerdote et al., 2005; Carrier et al., 2007; Costa et al., 2007; Jan et al., 2007). The first evidence of its pro-inflammatory potential is associated with mast cell activation that was examined by β -hexosaminidase release from RBL-2H3 cells in basal and antigen-stimulated conditions. Application of CBD (3-10 μ M) augmented

β -hexosaminidase release via a mechanism that excluded $G_{i/o}$ coupling and CB_1/CB_2 receptor mediation but involved intracellular Ca^{2+} rise in a $TRPV_1$ receptor-insensitive manner (Del Giudice et al., 2007).

In contrast, Vannacci et al. put forward a hypothesis of a down-regulation of the immunological response by CB_2 receptors (Vannacci et al., 2002; Vannacci et al., 2003; Vannacci et al., 2004). *In vitro*, 2-AG- and CP55940-mediated suppression of histamine release from guinea-pig mast cells was reversed by the non-selective NO synthase inhibitor, L-NAME and the selective CB_2 receptor antagonist, SR144528 (Vannacci et al., 2004). They suggested that endogenous 2-AG and exogenous CP55940 might evoke generation of NO and PGE_2 which in turn elevates the intracellular level of cGMP resulting in the inhibition of antigen-induced increase in intracellular Ca^{2+} , the key feature of mast cell degranulation (Vannacci et al., 2004).

Contradictory results have been obtained with the selective CB_2 receptor agonist, JWH133 (Jonsson et al., 2006). While *in vivo* this compound significantly reduced mast cell oedema, induced by the non-antigenic mast cell degranulator, compound 48/80, *in vitro* JWH133 neither inhibited [3H]-pyrilamine binding nor interacted with H_1 receptors (Jonsson et al., 2006). Also in the mouse paw skin, compound 48/80-induced β -hexosaminidase release was not altered by JWH133 treatment, indicating indirect action of JWH133 on mast cells in the model of plasma extravasation in the mouse ear pinna (Jonsson et al., 2006).

However, the contradictory data with human mast cells do not make the role of cannabinoids in the mast cell function less complex. On one hand, it has been shown that the human mast cell line HMC-1 does not express functional CB receptors and neither PEA nor AEA could affect tryptase release from these cells. On the other

hand, HMC-1 cells were able to transport and hydrolyze AEA by the action of FAAH (Maccarrone et al., 2000).

Clearly, there is a need to understand the role of cannabinoids in mast cell biology. Moreover, asthma research has been rekindled by studying the signalling pathways of mast cells and searching for new targets to inhibit their activation (Holgate and Polosa, 2008). In light of improvements in cannabinoid pharmacology, there is a considerable interest to elucidate how mast cell function may be modulated and might be manipulated to achieve therapeutic ends. One essential approach is offered by the identification of potential impact of cannabinoids in the functional response during antigen-induced challenges in the guinea-pig model of asthma.

Thus far, cannabinoids have shown the potential to regulate mast cell behaviour and to modulate the airway sensory nerve function. Notwithstanding this, possible mechanisms by which cannabinoids could modulate the airway epithelial function are still largely obscure. The following chapters open new avenues in the pharmacology of cannabinoids.

1.8 The airway epithelium

The surface of the airways is lined by a pseudostratified epithelium. The air-interfaced cells are predominantly ciliated columnar cells with mucus-secreting goblet (in the upper airways) and surfactant-secreting Clara cells (in the lower airways) (Martini, 1998). The airway epithelium forms a physical barrier by representing an interface between the external environment and tissue of the airway wall. Thus it provides protection to the surface of the respiratory tree against a constantly changing environment (Holgate, 2007a). Under normal circumstances the epithelium is impermeable and its barrier function is made possible through formation of tight junctions (TJs) which are localized at the apex of adjacent columnar cells. TJs are complex structures composed of multiple transmembrane proteins and adapter proteins to the cytoskeleton, and together through cell-cell and cell-extracellular matrix interactions (adherens junctions, desmosomes, and hemidesmosomes) they control paracellular transport of inhaled material (Holgate, 2008). In abnormal conditions (asthma), the epithelial permeability is increased due to impaired TJs (Holgate, 2008). In this respect, environmental factors such as respiratory viruses, bacteria, fungi and other triggers contribute to further disruption of structural integrity of the epithelium that leads to a chronic wound scenario. Building on this concept, the damaged epithelium that repairs incompletely, plays a crucial role in orchestration of the asthmatic response (Holgate, 2007a; Holgate, 2008).

1.8.1 Asthma and the airway epithelium

Beside the hypothesis of mast cell-ASM interaction as a pathological feature of asthma determining an asthma phenotype (chapter 1.7.2), there is an increasingly accepted concept that the airway epithelium takes centre stage in asthma. As an important orchestrator of this inflammatory disease, through secretion of cytokines, chemokines and growth factors, the epithelium is capable of supporting both chronic inflammatory and remodelling responses (Holgate, 2007b). This new concept roots in the activation of epithelial mesenchymal trophic unit (EMTU- epithelium, fibroblasts, myofibroblasts, smooth muscle and their secreted matrix, microvasculature and neural networks) that serves as a 'soil' to sustain Th2-type inflammation ('seed') (Holgate, 2007a). The consequence of the inter-relationship between epithelial injury and aberrant repair and chronic inflammation is the maintenance of the inflammatory response and a trigger of airway wall remodelling. In addition, the identification of novel susceptibility genes for asthma in the epithelium supports the possible fundamental origin of this chronic disease what might not be primarily in immune or inflammatory pathways (Holgate, 2007b; Holgate, 2008). This paradigm might explain the reason of an incomplete therapeutic response to anti-inflammatory drugs and offers a novel approach to asthma prevention and treatment which might lie in increased resistance of the airways against environmental inabity (Holgate, 2008).

1.8.2 Cannabinoids and the airway epithelium

Habitual marijuana smoking produces histopathologic evidence of airway inflammation and injury (goblet cell hyperplasia, loss of epithelial microvilli, cellular disorganization etc.) that is similar to that observed in tobacco smokers studied by bronchoscopy or light microscopy of tracheobronchial mucosal biopsy specimens (Gong et al., 1987; Fligiel et al., 1997; Tashkin et al., 2002). Similarly in the bronchial epithelium morphologic alterations due to marijuana smoking were accompanied by molecular abnormalities. The carcinogenic potential of marijuana smoke was supported by identification of abnormal molecular markers (Ki-67 nuclear proliferative antigen, EGRF, changes in actin and ploidy) which are typical for an increased risk of cancer development (Barsky et al., 1998; Tashkin et al., 2002).

In vitro, exposure of the main psychoactive constituent of marijuana, Δ^9 -THC (10 $\mu\text{g}/\text{ml}$) has shown deleterious effects on the lung epithelial tumor cell line A549 inducing a disruption of mitochondrial function and cell energetics (Sarafian et al., 2003). However, the possible toxicological effect of Δ^9 -THC on the human airway epithelium was re-evaluated and the investigation extended by gene expression studies (Sarafian et al., 2005). Again, Δ^9 -THC induced a time- and concentration-dependent decrease in cell viability, ATP level, and mitochondrial membrane potential in a primary culture of human small airway epithelial cells. Additionally targeted gene expression array revealed acute (24 hours) changes in expression of mRNAs for genes which are generally associated with inflammation, carcinogenesis and apoptosis (e.g. caspase-8, catalase, cytochrome P4501A1 etc.) (Sarafian et al., 2005).

This observation raised a question whether marijuana smoke also exerts these deleterious effects on lung cells *in vivo*. A nose-only exposure rat model confirmed that marijuana smoke can impair mitochondrial energetics of pulmonary epithelial cells (Sarafian et al., 2006).

A cannabinoid role in human colonic epithelial cells is well documented (Ihenetu et al., 2003; Wright et al., 2005; Mormina et al., 2006). Also, cannabinoids showed involvement in airway pathophysiology by their evident immunomodulatory properties regarding the regulation of the cytokine system (Jan et al., 2003). In a murine model of asthma, cannabinal and Δ^9 -THC effectively attenuated ovalbumin-induced allergic airway response, including IL-2 and Th2 cytokine (IL-4, IL-5, and IL-13) mRNA expression, serum IgE production and overproduction of mucus in the lungs (Jan et al., 2003).

Epithelial cells are an important component of the mucosal immune system. They perform a variety of immune functions, including secretion of cytokines in response to inflammatory stimuli. The pro-inflammatory cytokine, IL-8 is a neutrophil chemoattractant upregulated in severe asthma and COPD (Hamilton et al., 2003). In human bronchial epithelial 16HBE14o- cells IL-8 was markedly increased by activation of β -adrenoceptors [isoprenaline (β -agonist) and salbutamol (β_2 -agonist)] via a cAMP elevating pathway (Lindén et al., 1996). This *in vitro* study suggests that anti-asthmatic drugs may have an additive effect to a pro-inflammatory chemotactic signal (Lindén et al., 1996). To the best of our knowledge, the study has not been followed up in the same cells. However, one recently published paper pointed out that long-lasting β_2 -agonists salmeterol and formoterol significantly suppressed IL-8 secretion from TNF- α -stimulated airway epithelial A549 cells. This indicates that

activation of β_2 -adrenoceptors is associated with suppression of the pro-inflammatory IL-8 cytokine in airway epithelium (Chiu et al., 2007).

In contrast to Lindén et al. (1996), Gkoumassi et al. (2007) suggested that cannabinoids may exert anti-inflammatory effects through a decrease in cAMP formation. More specifically, the endocannabinoid VIR and the non-selective cannabinoid agonist CP55940 significantly inhibited TNF- α -induced IL-8 release in 16HBE14o- cells. The response was not affected by the CB₁ antagonist, SR141716A. Because the CB₂ antagonist, SR144528 by its own markedly reduced the TNF- α -induced IL-8 release from 16HBE14o- cells, it was not possible to confirm the identity of the CB₂ receptor involved in the inhibition of TNF- α -induced IL-8 release. Basal IL-8 release was not influenced by either antagonist (Gkoumassi et al., 2007). This report was published by our collaborator, Dr. Nelemans whose research group first identified the expression of CB₁ and CB₂ receptors, both at the level of mRNA and as proteins in 16HBE14o- cells (Gkoumassi et al., 2007). In addition, they investigated cAMP signalling by using a competitive [³H]-cAMP radioligand binding assay in these bronchial cells. They found that both CB₁ and CB₂ receptors were differentially coupled to AC. The endocannabinoid VIR and the non-selective cannabinoid agonist CP55940 decreased forskolin stimulated cAMP accumulation in a CB₂ receptor sensitive manner. The involvement of G_{i/o}-proteins in CB₂ receptor-mediated inhibition of cAMP formation was tested by PTX which enhanced the forskolin-induced cAMP accumulation in response to both cannabinoids. In contrast, the stimulatory response in the presence of PTX was prevented by SR141716A, indicating a CB₁ receptor-mediated increase of cAMP formation (Gkoumassi et al., 2007). They concluded that VIR might exert anti-inflammatory effects in the airways by CB₂ receptor-mediated modulation of cytokine release from the bronchial

epithelium (Gkoumassi et al., 2007). The precise role of cAMP signalling triggered by cannabinoids is still not well defined and further investigation is needed to help unfold the signalling events implicated in the immune response to cannabinoids in the bronchial epithelial cells.

1.8.3 Physiology and pharmacology of 16HBE14o- cells

The 16HBE14o- (16HBE) cell line was derived from human bronchial epithelium. Immortalization of epithelial cells by transfection with DNA encoding the SV-40 T antigen enabled the cells to avoid postcrisis and retain polarization and properties of TJs (Cozens et al., 1994; Wan et al., 2000). The morphology of 16HBE cells generally corresponds to the native epithelium with a cuboidal phenotype (Forbes and Ehrhardt, 2005). The cells express high level of the cystic fibrosis transmembrane conductance regulator (CFTR) mRNA and protein, the key molecule in Cl⁻ transport which is essential for fluid secretion in the airways (Cozens et al., 1994) and is defective in the disorder associated with airways mucus hypersecretion, cystic fibrosis (Welsh and Liedtke, 1986; Welsh and Fick, 1987). Therefore, 16HBE cells represent a useful model for studying ion transport and the function of CFTR.

In normal airway epithelium, stimulation of Cl⁻ secretion activates both apical Cl⁻ channels and basolateral K⁺ channels. Activation of K⁺ channels results from an increase in intracellular Ca²⁺ concentration ([Ca²⁺]_i) (Welsh and Liedtke, 1986). Two functional Cl⁻ conductances were identified in 16HBE cells (Koslowsky et al., 1994; Kunzelmann et al., 1994). Firstly, the whole-cell current activation of cAMP-dependent Cl⁻ channels was induced by cAMP-increasing agonists such as forskolin, isoprenaline and histamine. Reduction of the extracellular Cl⁻ concentration to 30 mM

by replacement with potassium gluconate evoked significant and reversible depolarization of the membrane potential of these cells. Additional single-channel recording revealed very small and not resolvable (<2 pS) Cl^- channels insensitive to forskolin (Kunzelmann et al., 1994).

Secondly, a Ca^{2+} -dependent Cl^- conductance has been investigated by application of bradykinin and the nucleotide ATP which primarily hyperpolarized the cell membrane, indicating an increase of the K^+ conductance via an increase in $[\text{Ca}^{2+}]_i$ because the Ca^{2+} ionophore ionomycin mimicked the action of extracellular ATP (Koslowsky et al., 1994). A biphasic response of the whole cell conductance was evoked by hypotonic cell swelling when the cells were exposed to a hypotonic bath solution (NaCl 72.5 mM). In these conditions the current increase was accompanied by an initial hyperpolarization followed by a depolarization of the membrane potential, suggesting the sequential activation of K^+ and Cl^- channels (Koslowsky et al., 1994). Taken together, the data suggest that the elevation of $[\text{Ca}^{2+}]_i$ increases basolateral K^+ secretion through K^+_{Ca} , thereby hyperpolarizing the apical membrane and increasing the driving force for Cl^- efflux through Ca^{2+} -dependent Cl^- channels as well as apical Cl^- channels that might be open under basal conditions (Welsh and Liedtke, 1986; Koslowsky et al., 1994; Walsh et al., 2000).

Beside Cl^- secretion, Na^+ absorption provides a balanced ion transport in the respiratory epithelium. Na^+ channels are present in apical membranes of airway epithelial cells but in established cell lines amiloride-sensitive Na^+ conductances are difficult to demonstrate. Cell culture conditions controlling cellular differentiation and polarization (permeable supports and butyrate as a differentiation promoting agent) and additional hormonal treatment (aldosterone and dexamethasone) appear to have an impact on both the expression of Na^+ channels and the electrical properties of

bronchial cells. While 16HBE cells grown on plastic dishes (treated with aldosterone and dexamethasone) expressed higher level of transcripts for Na⁺ channels, the same cells grown on pre-treated (aldosterone, dexamethasone or butyrate) permeable supports underwent more significant amiloride-induced membrane hyperpolarization. The hyperpolarization was slightly less significant in cells grown on plastic dishes treated with butyrate and the most significant hyperpolarization was in cells grown on permeable filters treated with butyrate. On one hand, K⁺_{Ca} channels were not affected by epithelial Na⁺ channels in amiloride-sensitive cells (cells grown on filters and/or treated with aldosterone, dexamethasone or butyrate). On the other hand, the culture conditions reduced the baseline forskolin-evoked Cl⁻ conductance, indicating that an amiloride-sensitive Na⁺ channel is accompanied by a reduction of the cAMP-dependent Cl⁻ channel in 16HBE cells (Kunzelmann et al., 1996).

Koslowsky et al. (1994) suggested that in a hypotonic solution 16HBE cells undergo swelling and activation of both K⁺ and Cl⁻ channels. Recent observation clarified that the Maxi-K⁺ channels (inhibited by TEA, Ba²⁺ or iberiotoxin) were reversibly activated following the exposure of 16HBE cells to a hypotonic solution. The electrophysiological data were supported by positive expression of Maxi-K⁺ channels in 16HBE cells using RT-PCR and western blotting (Fernandez-Fernandez et al., 2002).

The apical surface of the epithelium is covered by an airway surface liquid containing the nucleotide triphosphates, ATP and UTP (Bahra et al., 2004). ATP as an important signalling molecule binds to the purinergic P2 receptors of the airway epithelial cells. There are two types of P2 receptors, P2X is an ATP-gated Ca²⁺-permeable non-selective cation channel and P2Y is a GPCR. Their multiple subtypes are expressed on both apical and basolateral membrane domains and both of them increase cytosolic

Ca^{2+} , albeit via different mechanism. P2X receptor channels trigger signalling by mediating Ca^{2+} influx from extracellular stores by changing the plasma membrane potential causing a fast and sustained increase in $[\text{Ca}^{2+}]_i$. P2Y GPCRs trigger slower and only transient increase in $[\text{Ca}^{2+}]_i$ released from intracellular stores via phospholipaseC (PLC) mediated inositol 1,4,5-trisphosphate (IP_3) formation (Taylor et al., 1999; Schwiebert and Zsembery, 2003; Burnstock, 2004; Wolff et al., 2005).

In 16HBE cells the activation of purinergic P2Y2 receptors was first identified by using ATP and UTP which equipotently stimulated the Ca^{2+} -dependent Cl^- current (Koslowsky et al., 1994). The functional expression of the P2Y2 receptor was examined by performing an IP_3 assay in 16HBE cells. Both nucleotides (ATP, UTP but not ADP or UDP) evoked significant accumulation of IP_3 , confirming the signalling pathway triggered by the activation of P2Y2 receptors (Communi et al., 1999). Similarly, the P2X-specific mechanism has been also dissected out in 16HBE cells which express P2X4 receptors (Zsembery et al., 2003). The study demonstrated an ATP-induced sustained plateau of increased $[\text{Ca}^{2+}]_i$ which was evident only in Na^+ -free medium and the effect was potentiated by Zn^{2+} and by alkaline pH (Zsembery et al., 2003). Activation of both receptor subtypes evoked stimulation of Cl^- and K^+ efflux, and inhibition of Na^+ influx pathways (figure 1.10) (Schwiebert and Zsembery, 2003).

There is a considerable interest in the development of P2Y2 agonists to treat respiratory conditions where the mucociliary clearance is impaired. By hydrating the mucus (stimulating water secretion) P2Y2 agonists may have greater therapeutic potential than P2Y2 antagonists which might inhibit mucus hypersecretion (Kellerman, 2002; Burnstock, 2004; Abbracchio et al., 2006; Rogers and Barnes, 2006).

All ion transport mechanisms mentioned above can be modulated by changes in $[Ca^{2+}]_i$. These Ca^{2+} signals can arise from either the release of Ca^{2+} from intracellular stores or the influx of Ca^{2+} through the plasma membrane (Bahra et al., 2004). There are two major families of intracellular Ca^{2+} release channel, IP_3 receptors and ryanodine receptors. Both channels are regulated in a complex way by Ca^{2+} (low cytosolic $[Ca^{2+}]$ is stimulatory, high cytosolic $[Ca^{2+}]$ is inhibitory) or indirectly by a Ca^{2+} sensor molecule, calmodulin (Kasri et al., 2003; Kasri et al., 2004). The Ca^{2+} influx through the plasma membrane is stimulated via capacitative Ca^{2+} entry (CCE) and activated by emptying of stored Ca^{2+} (Bahra et al., 2004).

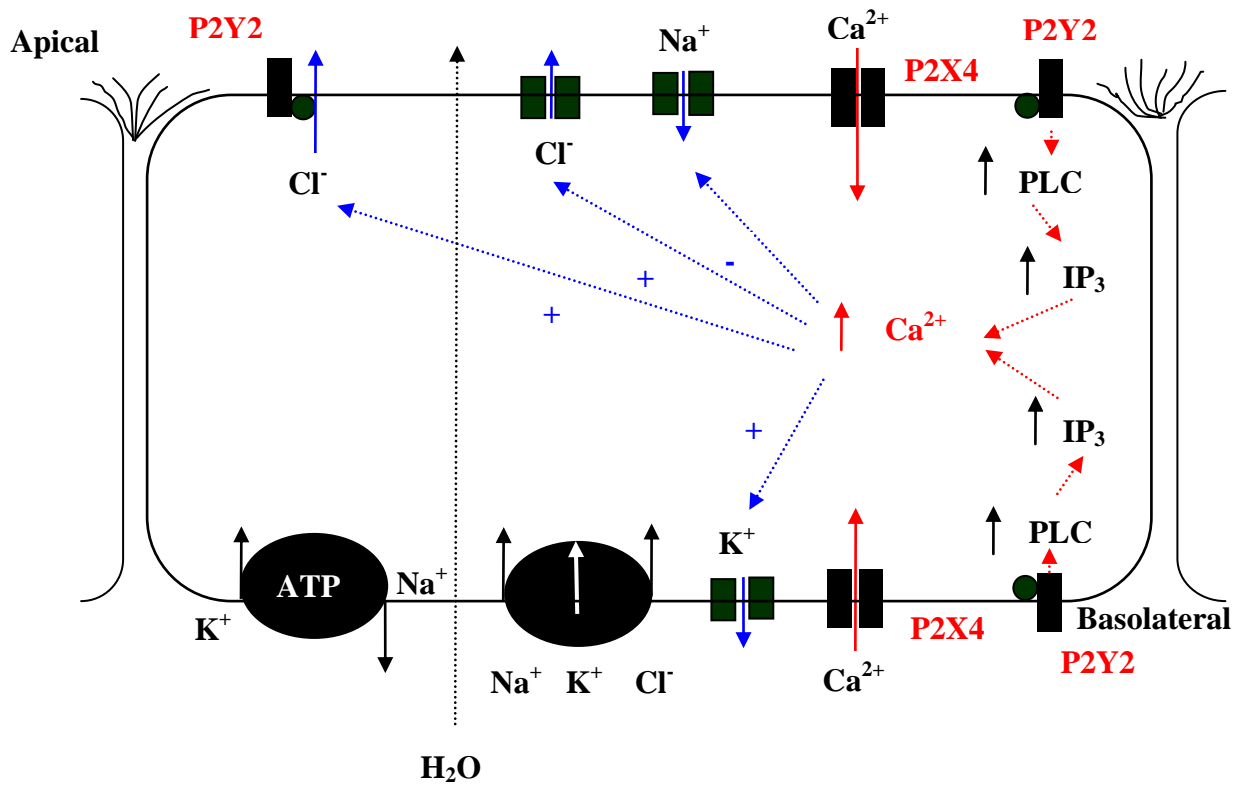

Figure 1.10 Purinergic signalling in a single airway epithelial cell (Schwiebert and Zsembery, 2003).

Purinergic P2 receptors mediate increases in cytosolic Ca^{2+} via different mechanisms: P2Y2 receptors via PLC-induced release of Ca^{2+} from intracellular stores, and P2X receptor channels, via direct influx of Ca^{2+} through the channel from extracellular Ca^{2+} stores.

1.8.4 Ca²⁺ signalling in 16HBE cells and other non-excitabile cell types

The 16HBE cell line was reported to be used as a model for studying ATP-induced Ca²⁺ signals. Single-cell [Ca²⁺]_i measurements revealed that only IP₃ receptors are involved in the intracellular Ca²⁺ release. Whereas ryanodine receptors are not functionally important in these cells because caffeine, the pharmacological activator of the ryanodine receptor failed to induce Ca²⁺ release in these cells (Sienaert et al., 1998). A control study showed that ATP in the presence of the purinergic antagonist suramin failed to increase intracellular Ca²⁺, confirming the purinergic (P2Y2) mediation of the response (Walsh et al., 2000). ATP was also able to induce a sustained increase in [Ca²⁺]_i which was evident only in Na⁺-free medium. The authors concluded that the P2X receptor was involved (Zsembery et al., 2003). In another study, apical and basolateral application of ATP evoked biphasic [Ca²⁺]_i elevations composed of an initial intracellular Ca²⁺ store release and secondary Ca²⁺ influx (Kerstan et al., 1999). The strictly basolateral localization of the CCE pathway in 16HBE cells was underpinned by the following investigation. Only removal of basolateral Ca²⁺ reduced the [Ca²⁺]_i plateau to basal values and also only removal of basolateral Ca²⁺ reduced the [Ca²⁺]_i plateau induced by depletion of intracellular Ca²⁺ stores (Kerstan et al., 1999). This might suggest a propagating signal from the apical to the basolateral side of the epithelium which then activates the CCE in 16HBE cells (Kerstan et al., 1999). The observation is in agreement with Bahra's (2004), who supported the concept of an apical P2Y receptor-mediated stimulus traversing airway epithelial cells to induce functional effects at the contralateral membrane (Bahra et al., 2004). In the 16HBE cell line lipoxin A₄, the biologically active eicosanoid and potent anti-inflammatory mediator, produced Ca²⁺ release from intracellular stores rather

than by Ca^{2+} entry from the extracellular compartment. The explanation is in the following. Since thapsigargin (a sarcoplasmic-endoplasmic reticulum Ca^{2+} -ATPase inhibitor initiating Ca^{2+} influx, depletes intracellular Ca^{2+} stores mediated by IP_3 and ryanodine receptors) abolished the effect of lipoxin A_4 , in Ca^{2+} -free solution with EGTA (chelating agent) the lipoxin A_4 -induced Ca^{2+} increase was not different from the control response (Bonnans et al., 2003).

The endocannabinoid AEA, similarly to lipoxin A_4 , is an eicosanoid. It can induce Ca^{2+} signalling in the human umbilical vein-derived endothelial cell line. The increase was only marginally blocked by the CB_1 antagonist, SR141716, insensitive to pertussis toxin and blocked by caffeine, suggesting the release of Ca^{2+} from caffeine-sensitive intracellular stores (Mombouli et al., 1999). In the calf pulmonary endothelial cell line, AEA can initiate Ca^{2+} elevation via CB_2 receptors linked to the activation of PLC, and formation of IP_3 . The PLC inhibitor, U73122 and the IP_3 receptor inhibitor, 2-APB prevented the effect of AEA. While the Ca^{2+} signalling in response to AEA was not sensitive to the CB_1 antagonist SR141716, the CB_2 antagonist, SR144528 produced an inhibition of the response. The involvement of the CB_2 receptor in these endothelial cells was confirmed by molecular identification using partial sequencing (Zoratti et al., 2003).

The effectiveness of the non-selective cannabinoid agonist, CP55940 in terms of the elevation of $[\text{Ca}^{2+}]_i$ has been also investigated in two non-excitable cell lines. Firstly, in Madin-Darby canine kidney cells, CP55940 induced concentration-dependent Ca^{2+} release, insensitive to cannabinoid antagonists, AM251 and AM281 (structural analogues of SR141716A). This synthetic cannabinoid exerted its effect by discharging intracellular Ca^{2+} in an IP_3 -independent manner, as the response was not altered by U73122 (PLC inhibitor, inhibitor of IP_3 synthesis), and by inducing

extracellular Ca^{2+} influx, as the response was significantly reduced in Ca^{2+} -free medium (Chou et al., 2001). Secondly, in hamster vas deferens smooth muscle cells, CP55940 induced a rise in $[\text{Ca}^{2+}]_i$ which was dependent on extracellular Ca^{2+} and modulated by thapsigargin-sensitive stores, indicating CCE. In addition, CP55940 evoked a pathway distinct from CCE involving arachidonic acid formation followed by activation of non-capacitative Ca^{2+} entry, through which arachidonic acid mediates Ca^{2+} influx (Demuth et al., 2005).

1.9 Aims and objectives

1.9.1 Aim

Despite the vast amount of research carried out in the cannabinoid field, few advances have been made associated with the effects of cannabinoids in the respiratory system. Using the isolated guinea-pig bronchial preparation and human bronchial epithelial cells, the aim of this study was to elucidate the possible role of cannabinoids in the airways by approaching different targets at tissue, cellular and molecular level.

1.9.2 Objectives

- To further evaluate the role of CB receptors in the sensory nerve function of isolated guinea-pig bronchi using EFS.
- To examine the functional pharmacology and mechanisms of actions of different cannabinoid ligands, their possible interaction with the proteins that inactivate the endogenous cannabinoids, and their possible interaction with the tachykininergic system in isolated guinea-pig bronchi.
- To investigate the potential role of cannabinoids against asthma using a guinea-pig model of allergic asthma associated with the mast cell activation.
- To observe the possible induction of signal transduction by cannabinoids in human bronchial epithelial cells using patch clamp and FLIPR techniques.
- To identify the CB receptors in human bronchial epithelial cells using conventional PCR and western blotting techniques.