

# A personalised assessment programme in Engineering Education

Mark Brian Russell

Submitted to the University of Hertfordshire in partial fulfilment  
of the requirements of the degree of Doctor of Philosophy.

March 2010

## Abstract

The number of students entering higher education has grown considerably during the last decade. High student numbers and the attendant large class sizes present significant challenges for teachers. Such challenges include knowing how to ensure students are engaging in appropriate out-of-class activity, how to provide prompt and personalised feedback and how to establish what students know and what they don't. If these challenges are left un-resolved the students' learning will not be well supported. This could ultimately lead to students failing modules.

This research presents a response to the growth of the student population and was prompted by a high failure rate in a core first year engineering module. The large numbers of students enrolled on the module presented exactly the kinds of challenges noted above, and the existing assessment regime did little to motivate student learning. The response presented in this thesis is the design, development, testing, implementation and evaluation of a new assessment programme; an approach to assessment that provides students with unique weekly tasks. The tasks were formally assessed and contributed towards the students' marks for the module.

To ensure the viability of the assessment programme, bespoke computer tools were developed to create, collect and mark the tasks, and to provide feedback to the students. The implementation has been evaluated through an exploration of the impact of the assessment programme on student support, teaching and student learning.

In three of the four years where the students were exposed to the assessment programme, the failure rate on the module decreased. The reduction in failure rate is arguably associated with the alignment of the assessment programme with good pedagogy. During the implementation of the assessment programme, the students were engaging in appropriate out-of-class activity in relation to the current topic area. The students had an opportunity to engage in dialogue with their peers and were receiving prompt and regular feedback. The teachers also benefited, since they were able to prepare lectures according to the students' level of demonstrable understanding.

In the case where the failure rate did not improve, the students themselves suggested they were downloading and using worked solutions to the problems from the internet. It is suggested that such activity neither provides meaningful opportunity to practise, nor alerts

the students to their genuine levels of understanding of the topic areas. In this case the students were *following* solution procedures rather than developing their own.

Student feedback on the assessment has been positive, with many noting how being led to engage with their studies was useful. Somewhat concerning was the feedback from students who noted 'they thought the work would help them with their examinations', 'they wanted the assessment programme used on other modules' and yet many indicated 'they would not have engaged with the activity if it did not count towards the module grade'.

## Acknowledgments

This research represents a considerable amount of personal commitment. I have spent numerous hours thinking about this research and its implications for my teaching and for my students' learning. Engaging in such activity has been both challenging and rewarding. I am grateful for the opportunity.

Accepting that any acknowledgment cannot adequately reflect the support received along the way I still want to thank some of the many colleagues that helped me.

I am grateful to the University of Hertfordshire for presenting an opportunity to engage in this research. I wish to thank my students. They trusted me and provided valuable feedback on their experience. I'm grateful to colleagues that questioned my work, my findings and suggestions that the WATS approach to assessment supports learning.

My supervisory team have been outstanding. Dr Jon Alltree and Dr Joy Jarvis have asked probing questions, made me think and provided extensive feedback on my work. Their input has been invaluable. They have smiled too when that was all I needed.

Dr Helen Barefoot was not part of my supervisory team but has been instrumental in getting me to this stage. Without Helen's continued nudging and encouragement I doubt I would be submitting this thesis. She believed in me and, along with my supervisory team, helped me see this work was worth showing and sharing. Helen is a great friend.

Finally, I wish to offer my sincere thanks to Professor Peter Bullen. As my Head of School, I have always felt Peter has supported my work. As my Principal Supervisor Peter helped me think deeply about my work and what it means. He has helped me turn ideas into reality with encouragement and timely advice. Peter has nudged when I needed nudging and left me alone when that was needed too. Peter, I am grateful for your supervision, for showing me what goodness looks like and for supporting me.

Thank you.

3 March 2010 8.20

# Table of Contents

<b>ABSTRACT</b> .....	<b>I</b>
<b>ACKNOWLEDGMENTS</b> .....	<b>III</b>
<b>1. INTRODUCTION</b> .....	<b>1</b>
1.1 THE CHANGING CONTEXT OF HIGHER EDUCATION.....	1
1.1.1 The growth in student numbers and factors affecting entry to Higher Education .....	1
1.1.2 Increasing class sizes .....	3
1.1.3 Factors affecting attrition in Higher Education .....	4
1.2 FLUID MECHANICS AND THERMODYNAMICS – A COMMON FIRST YEAR MODULE .....	5
1.3 THE NEED FOR THIS RESEARCH .....	7
1.3.1 Suggested reasons for high failure rate .....	8
1.4 ALIGNED TEACHING AND THE IMPACT OF ASSESSMENT .....	9
1.5 THE RESEARCH QUESTIONS .....	10
<b>2 INFLUENCES ON THE DESIGN OF THE ASSESSMENT PROGRAMME</b> .....	<b>12</b>
2.1 INFLUENCES FROM THE LITERATURE .....	12
2.1.1 Definitions and taxonomies of learning relating to Higher Education .....	12
2.1.2 Approaches to learning .....	15
2.1.3 Promoting learning .....	18
2.1.4 The purpose of assessment.....	24
2.1.5 Assessment and learning.....	30
2.1.6 Assessment and feedback .....	32
2.1.7 Regular assessments.....	38
2.1.8 Resource efficiency.....	40
2.1.9 The role of technology in assessments.....	43
2.2 THE RESEARCH SITUATION: UNIVERSITY, STUDENT GROUP AND HOST MODULE.....	49
2.2.1 The University .....	49
2.2.2 Study rates in AADE .....	50
2.2.3 Fluid Mechanics and Thermodynamics: An overview.....	51
2.2.4 Assessment arrangements .....	53
2.2.5 The students.....	53
2.2.6 The teaching team.....	55
2.3 DESIGN CONSIDERATIONS.....	55
2.3.1 Design theme 1. The assessment programme shall be aligned.....	56
2.3.2 Design theme 2: The assessment programme shall be learning focused .....	56
2.3.3 Design theme 3. The assessment programme shall be resource efficient.....	57
2.4 CLOSE OF CHAPTER TWO .....	58

<b>3</b>	<b>SYSTEM DEVELOPMENT</b>	<b>59</b>
3.1	THE WATS APPROACH TO ASSESSMENT: AN OVERVIEW	59
3.2	RESPONDING TO THE DESIGN THEMES	60
3.2.1	Features of the WATS approach to assessment supporting design theme 1	60
3.2.2	Features of the WATS approach to assessment supporting design theme 2	61
3.2.3	Features of the WATS approach to assessment supporting design theme 3	64
3.3	STUDENT AND TEACHER INTERACTIONS WITH THE ASSESSMENT PROGRAMME	66
3.3.1	The students' engagement with the WATS approach to assessment	67
3.3.2	The teachers' engagement with the WATS approach to assessment	68
3.4	THE NEED FOR TECHNOLOGY	71
3.4.1	Creating the WATS	72
3.4.2	The <i>WATS Set-Up Wizard</i> : Creating The Random Factors	74
3.4.3	Data collection: The <i>WATS Data Gatherer</i>	80
3.4.4	Marking and the provision of feedback	87
3.4.5	The WATS League Table	97
3.5	CLOSE OF CHAPTER THREE	98
<b>4</b>	<b>EVALUATION</b>	<b>99</b>
4.1	RESEARCH PARADIGMS	99
4.1.1	Research bias	100
4.1.2	Mixed-mode research: An alternative paradigm	101
4.2	INFLUENCES ON THE CHOICE OF A RESEARCH PARADIGM	101
4.2.1	The nature of the research questions	102
4.2.2	The nature of the discipline and potential audience for the study	102
4.2.3	The researcher's background	103
4.2.4	The nature of the research approach	103
4.2.5	Adopting a mixed-method approach: A justification	104
4.3	QUANTITATIVE METHODS	106
4.4	QUALITATIVE METHODS	107
4.4.2	Open responses; data collection and analysis	109
4.4.3	Additional qualitative data: Contributions to the discussion forum and e-mails	112
4.5	STUDENT BIAS	112
4.6	INTERVIEWS	113
4.7	DATA STORAGE	113
4.8	ETHICAL CONSIDERATIONS	114
4.9	SUMMARY OF DATA AND RESEARCH METHODS	115
4.10	CLOSE OF CHAPTER FOUR	116

<b>5 RESULTS AND PRELIMINARY DISCUSSION.....</b>	<b>117</b>
5.1 THE IMPACT OF THE ASSESSMENT PROGRAMME ON STUDENT SUPPORT .....	117
5.1.1 Monitoring student engagement.....	118
5.1.2 Stimulating additional teacher-student contact .....	119
5.2 THE IMPACT OF THE ASSESSMENT PROGRAMME ON STUDENT STUDY BEHAVIOURS .....	120
5.2.1 Engagement with the weekly tasks .....	120
5.2.2 Day of submission .....	122
5.2.3 Time of submission .....	123
5.2.4 Engagement with the discussion forum .....	124
5.2.5 WATS encourages active engagement - the student voice: .....	126
5.3 THE IMPACT OF THE ASSESSMENT PROGRAMME ON TEACHING AND LEARNING ORIENTED SUPPORT .....	127
5.3.1 WATS League Table .....	127
5.3.2 Adapting teaching sessions .....	129
5.3.3 Stimulating teacher reflections .....	132
5.3.4 Evaluating the difficulty of the WATS .....	132
5.3.5 Worked Solution .....	133
5.4 THE IMPACT OF THE ASSESSMENT PROGRAMME ON STUDENT PERFORMANCE.....	135
5.4.1 Performance on the WATS .....	135
5.4.2 Performance on the examination .....	137
5.4.3 Significance of the exam grade increase .....	140
5.4.4 WATS and examination grade correlations .....	141
5.4.5 Student voice; WATS supporting the exam .....	144
5.5 THE STUDENT VIEW OF THE ASSESSMENT PROGRAMME .....	145
5.5.1 Questionnaire responses .....	145
5.5.2 Free-text responses .....	146
5.5.3 Coding the free-text responses against the research questions.....	147
5.5.4 Interviews .....	151
5.6 CLOSE OF CHAPTER FIVE .....	154
<b>6 DISCUSSION.....</b>	<b>155</b>
6.1 ENHANCING STUDENT SUPPORT .....	155
6.2 ENHANCING TEACHING.....	158
6.2.1 Potential Challenges to teaching.....	160
6.3 ENHANCING STUDENT LEARNING .....	162
6.3.1 The influence of regular assessment tasks.....	162
6.3.2 The influence of marks on student engagement.....	166
6.3.3 Empowerment and the timing of student submissions.....	168
6.3.4 Learning through competition.....	170

6.3.5	Learning through collaboration (Collaboration versus Competition) .....	172
6.3.6	Student performance.....	174
6.3.7	Student improvement .....	176
6.3.8	The deviant case (2005-06) .....	177
6.3.9	Confirming a causal relationship .....	179
6.4	USE OF TECHNOLOGY .....	180
6.4.1	Making the assessment programme a practicable proposition.....	180
6.4.2	Transparency of marking .....	183
6.5	THE IMPACT OF THE RESEARCHER ON THE RESEARCH.....	183
6.6	GENERALISABLE PRINCIPLES.....	185
6.7	CLOSE OF CHAPTER SIX .....	186
<b>7</b>	<b>SUGGESTIONS FOR FUTURE WORK .....</b>	<b>187</b>
7.1	OPTIMISING ENGAGEMENT .....	187
7.1.1	Establishing a submission time to reduce cramming.....	187
7.1.2	Minimising the grade without compromising engagement.....	188
7.2	ENHANCING THE FEEDBACK CAPABILITY AND ENSURING ITS USE .....	188
7.2.1	Improvements to the feedback.....	188
7.2.2	Actively engaging students in the feedback and the use of feedback for resubmission.....	189
7.3	EMBEDDING AND EXPANDING USE.....	190
7.3.1	Embed the WATS tools into the MLE.....	190
<b>8</b>	<b>CONCLUSION .....</b>	<b>192</b>
8.1	THE NEED FOR THIS RESEARCH .....	192
8.2	THE WATS DEVELOPMENT .....	193
8.3	RESPONDING TO THE RESEARCH QUESTIONS .....	195
8.3.1	Conclusions relating to the impact of the assessment programme on student support.....	195
8.3.2	Conclusions relating to the impact of the assessment programme on student study behaviours.....	195
8.3.3	Conclusions relating to the impact of the assessment programme on student performance .....	197
8.3.4	Conclusions relating to the impact of the assessment programme on teaching and learning oriented support .....	197
8.3.5	Conclusions relating to the student perception of the usefulness of the WATS approach to assessment. ....	198
8.4	CONSISTENCY OF CONCLUSIONS .....	198
8.5	CLOSE OF THESIS.....	199



<b>REFERENCES .....</b>	<b>200</b>
<b>APPENDIX A. THE DEFINITIVE MODULE DOCUMENT .....</b>	<b>209</b>
<b>APPENDIX B. WATS 1-11.....</b>	<b>211</b>
<b>APPENDIX C. WORKED SOLUTIONS .....</b>	<b>223</b>
<b>APPENDIX D. THE PILOT WATS QUESTIONNAIRE (2002/03).....</b>	<b>264</b>
<b>APPENDIX E. THE REVISED WATS QUESTIONNAIRE .....</b>	<b>265</b>

# 1. Introduction

## 1.1 The changing context of Higher Education

### 1.1.1 The growth in student numbers and factors affecting entry to Higher Education

The number of students entering Higher Education (HE) has grown considerably during the last decade<sup>1</sup>. In 1997-98 there were around 1.8 million registered students. In 2007-08 this number grew to around 2.31 million. This growth in student numbers represents an increase of around 28%. The University of Hertfordshire (UH) is no exception to the sector trend of increasing student numbers. In fact over the same period UH has seen its numbers grow by a rate higher than the sector average. In 1997-98 the UH student population was 17,230 whereas in 2007-08 UH had 22,835 registered students; an increase of around 32%. Since 1994-95, when 10,814 students were registered, the student population of UH has more than doubled. The 2007-08 UH figures represent a 111% increase in registered students during the last 15 years (HESA, 2008).

At UH the vast majority of students are registered on full time undergraduate degree programmes. A comparison of UH and UK student numbers for 2007-08 & 1997-98 is shown in Table 1-1. Analysis of the data in Table 1-1 will show that UH has a higher proportion of students studying full time on undergraduate degree programmes than the sector average.

---

<sup>1</sup> At the time of writing (q4/2009) the latest statistics held on the HESA web site are those from 2007-08.

Table 1-1 Student numbers registered in HE (2007-08 & 1997-98)

	2007-08					1997-98				
	UH		UK*		UH-UK	UH		UK**		UH-UK
	<i>n</i>	%	<i>N</i>	%	%	<i>n</i>	%	<i>n</i>	%	%
PG	4050	17.7	501135	21.7	-4.0	2515	14.6	387001	21.5	-6.9
UG	18785	82.3	1804970	78.3	4.0	14715	85.4	1413063	78.5	6.9
Full time	17710	77.6	1480385	64.2	13.4	12314	71.5	1166127	64.8	6.7
Part time	5125	22.4	825720	35.8	-13.4	4916	28.5	633937	35.2	-6.7
UK	19165	83.9	1964315	85.2	-1.3	15069	87.5	1586800	88.2	-0.7
Other EU	570	2.5	112150	4.9	-2.4					
Non EU	3095	13.6	229645	10.0	3.6					
Overseas						2161	12.5	213264	11.8	-0.7
Total	22835		2306105			17230		1800064		

\* 166 institutions included in the HESA database

\*\* 176 institutions included in the HESA database

The expanding HE system, as represented by the data above, is not unique to UH nor constrained to the last 10-15 years. In 1996 Wisker & Brown (1996) raised grave concerns about the quality of student education due to increasing student numbers and reduction in *per capita* funding. Other writers have also cited the expanding HE system as a challenge to the quality of education (Biggs, 2003; Bridge, 2006; Ramsden, 1994).

The drive to increase the number of students entering HE suggests that universities are not only increasing the numbers of students from traditional backgrounds but are also increasing the number of students from diverse backgrounds (Ashwin, 2006). University teachers are not only facing a growing student population but a population that presents new and varied challenges. These challenges include supporting:

- *first generation HE students*; that is students coming from families with no previous experience of HE. In these situations there exists a potential for difference between the student and their university regarding expectations and understanding of 'studentship' within HE. The challenge for universities is the communication of expectations of behavior and study patterns and the provision of appropriate support and guidance to enable students to meet these expectations.
- *working students and students with family commitments*. In these situations the students need to balance their studies with their ongoing work and/or family commitments. The challenge for universities is to create teaching and learning

environments that do not compete for the students' attention, but are flexible and allow students to establish and maintain an appropriate study-work-life balance.

- *students that 'fall' into HE*; the growing student population suggests that some students currently entering HE may not have previously enrolled. These students may lack an intrinsic interest in their 'chosen' subject and may have enrolled simply because many of their peers have also enrolled. The challenge for university teachers is to develop the students' interest by motivation, showing relevance and demonstrating the importance of the chosen degree programme.

Maintaining the *status quo* and doing nothing to respond to the growing student population and diversity is not, it is argued, a strategy likely to support students through to graduation.

### 1.1.2 Increasing class sizes

In 1997 UH revamped some of its teaching accommodation and created larger teaching rooms. As a consequence of the refurbishment the University now has opportunities to teach more students simultaneously in the same teaching space. At around the same time as the refurbishment, the Department of Civil Engineering and the Department of Mechanical and Aeronautical Engineering merged to create the Department of Aerospace, Civil and Mechanical Engineering (ACME). The merger presented opportunities to review the range of degree programmes offered. The Department of ACME was keen to maintain its range of degree programmes but wanted to establish efficiency gains.

The approach taken by ACME was to create new modules that could support more than one of its degree programmes<sup>2</sup>. The new modules replaced some of the programme-specific modules which seemingly repeated some of the material for the different programmes. The new modules were oriented around engineering fundamentals and hence featured mainly in the first year of the degree programmes. Efficiency gains were obtained since the Department no longer taught variations of similar modules to different degree programmes but used the new teaching accommodation to teach the students together on the new common modules.

Looking at the texts offering advice and guidance on large group teaching (see for example Gibbs, Habeshaw & Habeshaw (1992), Gibbs and Jenkins (1992) and Cartbonne (1998)), it

---

<sup>2</sup> At the University of Hertfordshire degree programmes are constructed from modules.

seems that UH and ACME were not alone in moving to large group teaching to accommodate growing numbers of students. Challenges for teachers were not, however, constrained to issues such as classroom management and how to engage students in the new larger teaching spaces but were also associated with the attendant assessment activity. Assessing large groups is not a trivial activity. Race (2005b), for example, notes that the chances of cheating going unnoticed are higher in large classes and also that large classes reduce the opportunities for tutors to give good feedback. The educational context, particularly the growth of student numbers, was cited by Falchikov (2005, p. 159) as a “*major problem for teachers determined to take formative assessment seriously and to provide useful and quick feedback*”. The difficulty of assessing large numbers of students and providing timely formative feedback is also noted by McAllister & Alexander (2007). A useful briefing document specifically relating to the assessment of large groups is offered by Rust (2001). Rust presents a range of ideas that reduce the load on teaching staff and in doing so simultaneously enhance the learning potential of the assessment. Self-, peer- and group-assessment are suggested as examples, as is the use of Information and Communication Technology (ICT).

The focus on assessment is important, particularly at first year level, because of its noted relationship to retention.

### 1.1.3 Factors affecting attrition in Higher Education

When talking about students and their choices, Heywood (2000, p. 138) points out that “*many 18 year olds drift into Higher Education and make little effort at choosing courses or institutions*”. The consequences of which, he suggests, being “*students that are poorly prepared for entering HE, which, along with their lack of focus on where and what they wanted to study combine to produce an institutional incompatibility*” (ibid p. 139). According to Thomas (2008), many students struggle to make the transition from a more structured learning experience in schools and colleges to the greater autonomy in Higher Education. The difficulty of transition is also noted by Sevim (2005) in his study of retention in the USA. He notes the freshman (first) year as being the most difficult year in the students’ university experience and suggests factors contributing to attrition are i) adjustment to college life, ii) course selection that is not compatible with the background and capabilities of the student, and iii) time management.

Factors identified as being important to reduce the attrition of students are reported by Yorke (2003). In addition to the importance of a social dimension and establishing a supportive and friendly environment, Yorke seemingly identifies the first year as requiring significant input.

He suggests “*disproportionation of resources in favour of the first year experience, an emphasis on support leading up to, and during, the critically important first year of study, and an emphasis on formative assessment in the early phase of programmes*” (ibid p. 9).

## 1.2 Fluid Mechanics and Thermodynamics – a common first year module

Fluid mechanics and thermodynamics are core engineering subjects. Fluid mechanics deals with the properties of fluids, the behaviours of fluid flow and flow interaction with its surroundings. Thermodynamics, on the other hand, considers energy and the transformation of energy from one form to another. Given the breadth of relevance of fluids, fluid flow and energy across the engineering profession, it is apparent that these subject areas have relevance to many branches of engineering e.g. Aerospace Engineers, Automotive Engineers, Civil Engineers and Mechanical Engineers.

At UH, fluid mechanics and thermodynamics are taught in various guises to first, second and final year students. Following the merger and rationalisation of modules a combined first year module (*Fluid Mechanics and Thermodynamics*) was developed. The module provides an introduction to the subject areas and lays the foundations for more application and discipline-oriented modules in the second and final year. ‘Fluid Mechanics and Thermodynamics’ is studied by students registered on degree programmes in Aerospace, Automotive and Mechanical Engineering.

Notwithstanding the application-oriented nature of the follow-on second and final year modules, the first year module also includes an explicit intent to demonstrate the relevance of subject areas to the various engineering disciplines and their importance to wider society. Fluid mechanics and thermodynamics impact significantly on our lives. The aerodynamic design of aircraft and cars are influenced by our understanding of fluid mechanics; power plants are becoming more environmentally benign because of our understanding of thermodynamics; and the thermal comfort of many of the world’s citizens, in both hot and cold climates, are being helped because of our understanding of the various forms of heat transfer. Showing the relevance and importance of a subject domain to the students’ future career is a useful strategy to develop intrinsic interest and motivation in the students (France & Beaty, 1998); a strategy particularly important for those students that ‘fell’ into HE and this module.

Despite the enthusing and motivating efforts of the teaching team, many students still struggle with the first year module. Failure to succeed in the first year module immediately disadvantages students for their second and final year studies. Students progressing to the second year who have struggled with the first year module will have gaps in their comprehension and are also likely to have reduced confidence in their ability to succeed in the second year module. A fundamental principle of HE, according to Barnett (2007, p. 58) is that *“the student has to be right within herself, has to believe in herself, have faith in herself and have a measure of self-confidence in herself before anything of worth can happen in her learning”*. Barnett continues his discussion of ‘confidence and learning’ and essentially describes a mutually reinforcing circle when he discusses the relationship between the students’ progress and their confidence which supports the students’ will to learn. Self-confidence, it seems, is a pre-requisite for learning and developing an appropriate orientation for learning. The importance of developing students’ confidence in order to support their intrinsic motivation is also reported by Entwistle (1998).

In the extreme, for students who fail the first year module, the problem of lack of confidence and its relation to learning is exacerbated since the students will have to engage in their second year studies while also having to repeat the first year module.

Difficulties in understanding typically arise due to the terminology associated with the subject areas, which for many students is new, and also the reliance on mathematics. A lack of competency in mathematics is not a phenomenon unique to UH students but appears more widespread. Many universities, including UH, now provide additional mathematics support centres. Projects such as Helping Engineers Learn Mathematics (Harrison, 2008) demonstrate sector-wide concern about the mathematical ability of students on engineering programmes of study.

In 2000 the University deployed a Managed Learning Environment (MLE), StudyNet, and invited staff to use the new facility in ways that would supplement the ongoing teaching, learning and assessment interactions. Two members of the Fluid Mechanics and Thermodynamics teaching team took advantage of the new opportunity and used *StudyNet* to provide lecture notes, post news items and stimulate out-of-class engagement and student interaction by posting items to the discussion forum. Additionally, to help promote the value of the subject areas, and seek to develop the students’ intrinsic interest, links to relevant web sites were provided.

The University was developing its capabilities in blended learning and members of teaching staff were exploring how technology might enhance the teaching, learning and assessment interactions. The University defines blended learning as *“educational provision where high quality e-learning opportunities and excellent campus-based learning are combined or blended in coherent, reflective and innovative ways so that learning is enhanced and choice is increased”*.

### 1.3 The need for this research

Having developed an example of blended learning, it was particularly disappointing to note that in 2001-02, 51% of students failed the Fluid Mechanics and Thermodynamics module at the first attempt.

When faced with high failure rates lecturers have two choices. First, they can lay the blame for failure elsewhere. Blaming someone else in the educational situation is not uncommon and is a feature of teachers who see a limited relationship between their teaching and their students' learning (Ramsden, 1994). In relation to this module, the blame could have been laid with the admissions team with the suggestion that the students' entrance qualifications were not sufficient to prepare them for the module. The teaching team might also have laid the blame more directly with the students, the justification being that the teaching team had done all they had done in previous years and more, and the students were still not engaging as they should.

The second choice available to the teaching team would be to research the failing situation and establish possible causes for the high failure rate. The students' failing ultimately represents a measure of the students' learning and also the teaching, since teaching and learning are arguably related and non-separable activities (Miller & Parlett, 1974).

Shifting the blame to the students with the suggestion that they were not as engaged with their studies as their peers were 10 or 20 years ago was discounted as the root cause of the failing. If we do indeed look back 10 or 20 years we will find our predecessors suggesting we look back a further 10 or 20 years for more engaged and diligent students (France & Beaty, 1998).

The high student failure rate demands attention and a more reflective analysis of the impacting factors. The research presented in this thesis arises as a consequence of the high



failure rate and explores the issues leading to the failure rate. The research develops, deploys and evaluates an appropriate, research-informed, response to the high failure rate.

### 1.3.1 Suggested reasons for high failure rate

The reasons for the high failure rate are complex and multi-factored. It is likely that each student will have their own reasons for misunderstanding and subsequent failure. Accepting the uniqueness of each student's situation it is possible to establish that a lack of student engagement was a central theme of the failure. Module teachers indicated that many students attended tutorial sessions unprepared and demonstrated little evidence of relevant study out of class.

A lack of student engagement creates additional learning-oriented consequences. Students would not have received any ongoing feedback on their activity since no or limited activity was taking place. Lack of feedback is detrimental to learning. According to Gosling (2007, p. 172) *"one of the most important aspects of supporting learning is the feedback the students receive on their work"*. With no ongoing feedback there was no potential for the students to act on feedback and hence consolidate or correct their own learning and understanding. Acting on feedback is a repeated theme of good assessment practice (Gibbs & Simpson, 2004; Nicol & Macfarlane-Dick, 2006). A useful strategy for learning is to let students see their own misconceptions (Biggs, 2003). With limited student engagement, neither students nor teachers would have been aware of what the students knew and what they didn't. According to Heywood (2000, p. 205) *"the fact that students have misconceptions puts an onus on teachers to respond"*. In responding to the students' misconceptions the teaching is able to be much more student-centric and hence better support student learning.

The lack of student engagement could not be blamed solely on the students. The assessment regime had over-emphasised the measurement of learning over the promotion and development of student learning. The assessment, a phase test set at week eight in an eleven-week semester, did little to stimulate learning or encourage learning-oriented behaviours. The phase test, for instance:

- Provided limited encouragement for students to study throughout the semester
- Provided limited encouragement for students to distribute their effort across all areas of the curriculum
- Did not provide appropriate opportunities for students to receive and act on feedback in a way that could enhance their learning

- Did not provide regular encouragement for students to share and learn with their peers
- Did not provide teachers with information about their students' progress
- Did not encourage a dialogue about learning

Arguably the phase test may have had some validity regarding its content, i.e. its alignment with the learning outcomes described in the Definitive Module Document (DMD), but it had limited, if any, validity in terms of promoting or encouraging student learning. The phase test was too end-of-process oriented, monologic and not aligned with principles of good assessment practice e.g. (Gibbs & Simpson, 2004; Nicol, 2007).

#### 1.4 Aligned teaching and the impact of assessment

The benefits of intrinsic motivation for learning are a repeated theme in a volume dedicated to student motivation (Brown, Armstrong, & Thompson, 1998). It is apparent, however, that the motivational stimulus created by extrinsic drivers should not be forgotten. Extrinsic motivation relates to rewards such as grades and progress and hence is often associated with assessment activity. An apparent dominance of assessment in shaping students' effort is suggested in statements such as *“assessment shapes learning, so if you want to change learning then change the assessment method”* (Brown, 2001, p. 6) and *“what influenced students most was not the teaching but the assessment”* (Gibbs & Simpson, 2004, p. 4). Although the apparent impact of assessment on student study behaviours might be disappointing, it raises the importance of assessment for teachers and curriculum designers.

Curriculum design is an essential planning process that deals with *what*, as well as *how*, material is taught. It focuses on the teaching and learning activities as well as the settings which best supports them. Within the curriculum planning process is the necessity to establish how the student learning will be assessed. A curriculum that joins together what is taught (and how) with how it will be assessed is referred to as an aligned curriculum or aligned teaching (Biggs, 2003). In aligned teaching assessment is an integrated component of the curriculum and not an add-on or an after-thought. Assessment is, therefore, an essential component in the learning activity and promotes learning-oriented behaviours.

The necessary integration of assessment with teaching and learning activities has arisen because of the noted significant impact of assessment on students' study behaviours, learning and, ultimately, the outcomes of a course (Wakeford, 2007). According to Boud (2005, p. 37) *“every act of assessment gives a message to students about what they should*

*be learning and how they should be going about it". According to Rust (2001, p. 7) assessment also indicates to the students what they can seemingly ignore, "if less of a course is sampled through assessment, students may very easily become selectively negligent, only studying in depth those parts they think/know will be assessed".*

Assessment is clearly significant and indicates to the students such things as:

- when they need to pick up their books and when they don't;
- what is important and what is not;
- how much time they need to spend on their studies and how this time should be distributed across the topics/weeks;
- whether they need to study in an atomistic or holistic mode;
- what their approaches to learning will be i.e. a surface or deep approach, and
- if their knowledge needs to remain situated in the discipline area or abstracted outside of it.

Given that some of the students' responses and actions to the above are often not aligned with those expected by their teachers, the unavoidable impact of assessment is referred to as the hidden curriculum (Snyder, 1970) or the backwash of assessment (Biggs, 2003).

Recognising that the backwash of assessment is an inescapable feature of assessment is important if a positive learning benefit is to arise. Teachers should not shy away from these potential difficulties but rather construct assessment regimes that set out to counter inappropriate study behaviours. Carefully constructed assessment can help align the students' behaviours with those expected by the teachers, the module and the university.

Good assessments, therefore, should not just provide students with a task. Good assessments are designed activities that set out clear expectations and are aligned with the module learning outcomes.

## 1.5 The research questions

The research commences with a response to the question: What are the requirements for a system that provides regular assessments and feedback to the learners and teachers within a mass HE system?

In response to the research question, this research, and hence the contribution made by the research, is sequenced around:

- an analysis of requirements (defining the needs of the assessment programme);
- designing and building an assessment programme to meet the requirements;
- testing and implementing the assessment programme alongside the existing teaching and learning settings.

Following the development and implementation of the assessment programme, the research and associated questions move towards evaluation of the impact of the assessment programme on:

- i) student support;
- ii) student study behaviours;
- iii) teaching and the provision of learning oriented support;
- iv) student performance.

Additionally the research also evaluates the students' views of the assessment programme.

The following chapters describe the contribution made by the research in relation to the design-build-evaluate sequence. Chapter Two reviews the influences on the design and concludes with an analysis of requirements. The design and development of the assessment programme is presented in Chapter Three. An evaluation strategy is presented in Chapter Four. Chapters Five and Six present the results and discussion and form the evaluation of the developed assessment programme.

Chapter Seven suggests additional work and Chapter Eight, the conclusion, draws the research to a close.

In sum, this research explores an approach to assessment designed, developed and implemented to respond to the high failure rate in Fluid Mechanics and Thermodynamics, a first year module in the School of Aerospace, Automotive and Design Engineering at the University of Hertfordshire. Although the context for the assessment programme is situated in an engineering module, there are features of the context that are shared with other modules, other disciplinary areas and other universities.

## 2 Influences on the design of the assessment programme

Successful product development includes an analysis of locally relevant requirements, and product developments in educational settings are no exception. A generalised approach to instructional design sets out a series of interrelated events which explicitly uses as a starting point an analysis of need. This is followed by design activity, development activity, implementation and concludes with evaluation (Molenda, 2003). Similarly the Conceive, Design, Implement and Operate (CDIO) approach to Engineering curricular, which was designed to mirror what engineers do in practice (Crawley, Malmqvist, Ostlund, & Brodeur, 2007) firmly locates the definition of customer needs, i.e. a user analysis, in the conception phase.

This chapter undertakes an analysis of need for the design of the assessment programme and concludes with a set of principles to guide and steer the design and development phases. The analysis of need draws on the influences and insights from the associated literature and the local context of the University, the module and the students.

### 2.1 Influences from the literature

#### 2.1.1 Definitions and taxonomies of learning relating to Higher Education

Learning is a complex cognitive process with numerous definitions. Many definitions suggest that learning is a relatively permanent change in behaviour or thinking that arises as a result of reinforced practice (Kimble, 1967; Turner-Bisset, 2001). Two principle themes emerge from the definitions of learning. First, that learning is the acquisition of new skills or knowledge and hence involves a personal change (behaviour or thinking) and second, that learning occurs as a consequence of action or involvement in a process (reinforced action). Such definitions of learning note the observable product as well as the importance of a process to provide the opportunity to acquire knowledge and personal change, and also to develop appropriate student study behaviours.

Kolb's (2003) experiential learning cycle implies the importance of process within learning when he identifies four related components of a learning cycle. The cycle includes a necessity to gain first-hand *concrete experience* which is followed by *reflection*, *abstraction/generalisations* and *future planning*. Gaining a personal and concrete experience provides something to reflect on. While a cycle might typically focus on a single learning

event, it is helpful also to think of a connectivity between cycles to create an ever growing learning spiral; cycles that feed in to other cycles.

According to Race (2001) five factors can be seen as important in underpinning successful learning; *wanting to learn, needing to learn, learning by doing, learning through feedback and digesting/sense making*. Rather than seeing these factors as having a fixed linearity or cyclic pattern, as implied by Kolb, Race suggests the factors interrelate with each other, and learning occurs as the learners pass through the factors in a variety of directions.

In addition to the product-process perspective of learning, other classifications (or taxonomies) have been proposed to classify the different levels of intended, or observed, learning. Bloom (1956) and his co-workers identified learning descriptors in the cognitive (thinking and knowing) domain. These descriptors start, at the lower end of the taxonomy, with *knowledge* and move through *comprehension, application, analysis* and *synthesis* and conclude, at the higher end, with *evaluation*. The taxonomy is presented as a hierarchy with the higher cognitive levels subsuming the lower cognitive levels. This taxonomy is known as Bloom's Taxonomy of Educational Objectives or more simply Bloom's Taxonomy. Anderson & Krathwohl (2000) provide a revised view of Bloom's work and have *creating knowledge* at the top of their taxonomy. Anderson's taxonomy starts at the lower end with *remembering* and moves through *understanding, applying, analysing, evaluating* before reaching *creating knowledge*. Although the revised taxonomy draws heavily on the initial work of Bloom, its change in language from nouns to verbs subtly indicates the value of activity to the learning task across the different levels of the taxonomy.

The importance of activity to learning is supported in various proposals of good pedagogic practice. Ellis & Worthington (1994), in their Ten Effective Teaching Principles, suggest students learn more when they are engaged actively during an instructional task. Chickering & Gamson (1987) suggest good practice encourages active learning, and underscore the idea by noting that learning is not a spectator sport. Mentkowski & Associates (2000, p. 240) suggest "*another principle central for student development of ability is that learning is active*". They go on to say that "*Students cannot learn to think or solve problems just by listening to the most informed professor or reading the most erudite text*" (Ibid p.240). Biggs (2003) describes a specific example of different levels of activity superimposed on reading. The students' activity increased from reading silently, underlining important words, writing out the key sentences containing those words, rewriting sentences with their own words through to teaching somebody else the material. A "*strong correlation between extent of activity and the*

*efficiency of learning*” is offered along with the conclusion that “*activity simply heightens arousal, which makes performance more efficient*” (ibid p. 79).

The culmination of student activity (process) is often observable learning or an artefact that can be assessed or judged (product). Notions of observable learning feature in an alternative classification or learning taxonomy as offered by Biggs & Collis (1982). In their Structure of the Observed Learning Outcomes (SOLO) taxonomy, Biggs & Collis characterise the levels of *observed* student learning in five discrete categories:

- *pre-structural understanding* where the students demonstrate no understanding of the task and/or topic area;
- *unistructural understanding* where the students' understanding is limited to a single concept;
- *multi-structural understanding* where the students draw on different concepts but they fail to see or demonstrate any relationship between them;
- *relational* where the students acknowledge and describe relationships between the different parts of their knowledge;
- *extended abstracted* where the students are able to generalise and abstract their knowledge outside the local domain.

Consistent with Bloom's taxonomy, the higher levels of the SOLO taxonomy subsume the lower levels of the taxonomy.

While the nature of the SOLO taxonomy implies it is better suited to classifying students' discourse (see for example the coding of students' contributions within a discussion forum (Anderson & Krathwohl, 2000; Brown, Smyth, & Mainka, 2006)), the SOLO taxonomy has also been used to classify questions against, and hence identify, the anticipated or intended learning associated with forthcoming assessment tasks. Bridge (2005), for instance, codes assessment tasks and the likely cognitive demand they will stimulate against the SOLO taxonomy. The example of classifying assessment tasks and the students' expected learning, rather than classifying their observable learning, is typical also of the use to which Bloom's taxonomy is often applied. A good example of the use of Bloom's taxonomy to classify the cognitive level of multiple choice questions is offered by Carneson, Delpierre & Masters (1996). In addition to offering a more structured learning experience, i.e. through a hierarchy, the classifications help teachers see which levels of the taxonomy the students are able to operate within.

Another taxonomy using language similar to that of the SOLO taxonomy is presented by Hasselgren (1981). Following interviews with student teachers Hasselgren offers four categories of learning descriptions; these being *fragmentary description*, *partialistic description*, *chronological description* and *abstract description*.

There are obvious similarities in the identified taxonomies, that is, the taxonomies are hierarchical and move from being information-focused at the lower end of the taxonomy, towards more sophisticated and interpretative levels of learning, such as abstracting and extending, at the higher end of the taxonomy. Perhaps the most significant difference is the fact that each level of Bloom's and its revised taxonomy appears to have an important place in students' learning. Indeed, in some sense Bloom's lower levels could be viewed as being the foundations on which the higher levels of learning are constructed. In contrast, the lowest level of the SOLO taxonomy, pre-structural understanding, demonstrates no useful understanding and, apart from being used to highlight misconceptions, or a lack of understanding, it offers no foundation on which higher level learning can be meaningfully constructed.

The importance of using the lower level categorisations of learning to support the higher level learning activities is explicitly recognised by Hoffman (2005, p. 5) when he suggests "*the process of learning is interrupted if one or more of the subsystems are interrupted e.g., if the basis of factual knowledge is not broad enough, then conceptual knowledge will have gaps*". Hoffman's work suggests that not only do the taxonomies classify the different levels of learning but they also show how the various levels support and scaffold each other.

### 2.1.2 Approaches to learning

A parallel can be drawn between the levels of learning, categorised by the different taxonomies, and the ways in which students are oriented towards, or 'approach', their studies. Hence in addition to classifying students' observed or intended learning, as implied by the use of a taxonomy, another area of interest is that of students' approaches to learning. The foundations for inquiry into students' approaches to learning were established in the early 1970's; an overview of the studies and findings from the early contributors is given by Marton & Saljo (1984). The approaches to learning research suggests that students could be characterised as adopting either a *surface* or a *deep* approach to learning.

A surface approach is characterised by a student that sees the ability to reproduce facts or duplicate the teacher's notes as being important. Students adopting a surface approach see no value in developing relationships either within or across subjects. It is facts, not the



connections between them, that are important to students adopting a surface approach to learning. The surface approach contrasts with the deep approach to learning which is exemplified by students seeking to develop relationships within and across subject areas. Students adopting a deep approach do not view the acquisition of disconnected facts as learning but look for connections and meaning within their growing knowledge base. Pask (1976) identifies similar traits, but uses a different language to characterise two alternative strategies of learning. These characterisations are *serialists* or *holists*. Serialist students have characteristics similar to the students adopting a surface approach and holists are defined as those students who attempt to see the whole, the meaning, and hence are similar to the students adopting a deep approach to learning.

Work by Marton & Saljo (1984) added a third orientation, a *strategic* approach to learning. Students adopting a strategic approach display behaviours and learning strategies that appear to be driven for the purpose of gaining marks. Students adopting a strategic approach look for exam cues, are systematic in the use of their time and effort and are likely to disregard parts of the curriculum they do not see as important to the examination. Following interviews with students, Miller & Parlett (1974) appear to support the identification of this third approach (strategic) when they suggest students can be seen as being *cue-seeking*, *cue-conscious* or *cue-deaf*. Race (2005a) modifies the language and offers *cue-oblivious* in lieu of *cue-deaf*. Students classified as being *cue-oblivious* don't recognise any cues or guidance about the examination.

Although research into approaches to learning offers three alternative positions, it also suggests that the approach the students adopt is not singly a factor of students' personal motivation. It is also influenced by the learning environment in which the students are immersed. This does not conflict with the view that students are individuals, have their own traits, their own cognitive profile as implied by their multiple intelligences (Gardner, 1993) or individual learning style, examples of which include the characterisations described by Fleming (2001) and Honey & Mumford (1992). However, it also signals the importance of the prevailing teaching, learning and assessment environment.

Approaches to learning, therefore, characterise the student's behaviours and their orientation towards their studies rather than characterise the student *per se*. Given the emphasis and importance of the local teaching, learning and assessment environment in orienting the student's approach it is possible for a student to be inadvertently motivated to adopt a surface approach to learning within one module, whilst simultaneously being more appropriately motivated to adopt a deep approach to their studies within another module.

Components of the teaching, learning and assessment environment likely to impact on students' approaches to learning is given in Table 2-1.

Table 2-1 Influences on student approaches to learning

<p><b>Surface approaches to learning might be encouraged by ...</b></p> <p>Assessment methods emphasising recall or the application of trivial procedural knowledge</p> <p>Assessment methods that create anxiety</p> <p>Cynical or conflicting messages about rewards</p> <p>An excessive amount of material in the curriculum</p> <p>Poor or absent feedback on progress</p> <p>Lack of independence in studying</p> <p>Lack of interest in and background knowledge of the subject matter</p> <p>Previous experiences of educational establishments that encourage these approaches</p>
<p><b>Deep approaches to learning might be encouraged by ...</b></p> <p>Teaching and assessment methods that foster active and long term engagement with learning tasks</p> <p>Stimulating and considerate teaching, especially teaching which demonstrates the teacher's personal commitment to the subject matter and stresses its meaning and relevance to the students</p> <p>Clearly stated academic expectations</p> <p>Interest in and background knowledge of the subject matter</p> <p>Previous experience of educational settings that encourage these approaches</p>

Source: (Biggs, 2003)

Instruments used to establish students' likely orientation include the Approaches to Study Inventory (ASI) and the Study Process Questionnaire (Biggs, 1987). By definition, given the observations regarding the importance of the local teaching and learning environment, use of these instruments is more meaningful when administered at module level.

### 2.1.3 Promoting learning

Promoting learning, creating opportunities for students to move through the various levels of a learning taxonomy and encouraging study behaviours likely to lead to the adoption of a deep approach to learning is of interest to teachers and curriculum/instructional designers alike.

Teachers particularly have an important role to play in encouraging appropriate study behaviours and, ultimately, student learning. It is the teachers that typically design and create the learning activities; it is the teachers that will set out their expectations and subsequently construct the learning environment. Teachers create, and indeed are, the interface between the students and the curriculum. This nexus between teaching and learning is reinforced by Ramsden (1994, p. 5) when he suggests “*the aim of teaching is simple: it is to make student learning possible*” and Race (1998) when he talks of how teaching might create a thirst for learning. Unfortunately, despite the best efforts of many teachers, and the inseparable relationship between teaching and learning (Miller & Parlett, 1974), some students still remind us that teaching does not equal learning. This point is reinforced by Yorke (1999, p. 101) when he writes “*it is appropriate to recall that teaching is not necessarily followed by good learning*”.

When thinking about teaching it is possible to conceive a continuum between instructivism and constructivism. This continuum is described by Ramsden (1994) when he presents three alternative *theories*, which are arguably better considered as views, of teaching. To continue with the language of Ramsden, the first theory is described as *teaching as telling or transmission* and might be characterised as a situation where information is given from the teacher (expert) to the student (novice). The first theory implies that there is an authority associated with the content or procedures being displayed. The second theory presents *teaching as organising student activity* and the third theory as *teaching that makes learning possible*. These three theories are offered as hierarchical with the latter theories subsuming the previous. As the theories progress through the hierarchy, or along the continuum, there is a shift from teacher-as-expert to teacher-as-director, facilitator or orchestrator of learning; aligned with constructivism. The shift through the continuum presents increasingly more opportunities for students to construct their own knowledge and gain a first-hand view of the subject; the concrete experience noted by Kolb (2003); rather than receive a second-hand, teacher’s view. It is this shift from seeing the teacher as expert, as implied by instructivism, through to constructivism that is likely to enhance the learning experience and better support the potential for learning. Definitions of constructivism converge on notions that it

(constructivism) focuses on knowledge construction and not knowledge reproduction (Cartelli et al., 2008; Herrington & Standen, 2000).

A useful starting point for the development of an appropriate learning-oriented teaching strategy is offered by Chickering & Gamson (1987) in their *Seven Principles of Good Practice in Undergraduate Education*. In their summary of research Chickering and Gamson suggest that good practice for undergraduate education:

- Encourages contact between students and faculty;
- Develops reciprocity and co-operation amongst student;
- Encourages active learning;
- Emphasises time on task;
- Gives prompt feedback;
- Communicates high expectations;
- Respects diverse talents and ways of learning.

These principles are offered as guidelines for teachers and are not constrained to support the learning of particular student groups, genders nor subject areas. Other principles are offered by Ramsden (1994) and Fink (1999).

Ramsden's Six Key Principles of Effective Teaching in Higher Education comprise:

- [Develop] interest and motivation;
- [Show] concern and respect for students and student learning;
- [Provide] appropriate assessment and feedback;
- [Establish] clear goals and intellectual challenge;
- [Stimulate] independence, control and active engagement;
- [Provide opportunities to] learn from students.

Fink's Five Principles of Course Design comprise:

- Challenging students to higher level learning;
- Using active forms of learning;
- Giving frequent and immediate feedback to students on the quality of their learning;
- Using a structured sequence of different learning activities;
- Having a fair system for assessing and grading students.

Since the three lists are essentially all offered as good practice principles, it will be of little surprise that there is much overlap in the three lists. The overlap in the principles, referenced against Chickering and Gamson, is shown in Table 2-2.

Table 2-2 Similarities between principles of good teaching practice

<i>Chickering and Gamson</i>	<i>Ramsden</i>	<i>Fink</i>
Encourages contact between students and faculty	[Show] concern and respect for students and student learning / [Provide opportunities to] learn from students	
Develops reciprocity and co-operation amongst students		
Encourages active learning	[Stimulate] independence, control and <i>active engagement</i>	Using active forms of learning
Emphasises time-on-task		<i>Using a structured sequence</i> of different learning activities
Gives prompt feedback	[Provide] appropriate assessment and feedback	Giving frequent and immediate feedback to students on the quality of their learning.
Communicates high expectations	[Establish] clear goals and intellectual challenge	Challenging students to higher level learning
Respects diverse talents and ways of learning	[Stimulate] independence, control and active engagement	Using a structured sequence of <i>different learning activities</i>

Although useful, the various sets of principles do not offer specific solutions. Gagne, Briggs, & Wagner (1992), however, offer Nine Steps in Instructional Design to provide a sequence of events / activities to support learning. These steps are:

- Gain attention;
- Inform learners of objectives;
- Stimulate recall;
- Present the content;
- Provide learning guidance;
- Elicit performance (practice);
- Provide feedback;

- Assess performance;
- Enhance retention and transfer to the job.

Individual components of Gagne's steps have been confirmed as being useful elsewhere too. The value of providing practice opportunity within a curriculum, which is arguably a manifestation of student activity, is argued by McAlpine (2004) and is a central component of her learning model. Activity was also noted as being important in the earlier definitions of learning. Further, showing the importance of the learning activity and hence developing the students' intrinsic motivation (notions that are likely to enhance retention and transfer to the job) are noted by Combes (2004).

Perhaps one of the most obvious issues arising from Gagne's Nine Steps is that associated with *presenting content*. This appears to suggest that teachers hold the knowledge and simply 'deliver' or 'transmit' that knowledge to the 'receivers'; the students. This concept of presenting the content or transmitting information appears to be aligned with Ramsden's first theory of teaching, i.e. an instructivist view of teaching. Hence, although offering a useful structure, it might also inadvertently suggest to the students that there exists one answer, one truth, and that the knowledge, or truth, resides with the teacher. The role of the students in such teaching environments might be perceived as listening for, and being able to recall, the truths offered by their teachers. This view of truth, where students believe a duality exists, a right or wrong answer, and their role is to separate right from wrong, is analogous to the first stages of Perry's continuum of Intellectual and Ethical Development (Perry, 1970). At the opposite end of Perry's continuum exists an alternative position where pluralistic uncertainty exists and is dependant on the observer's experience. Proponents of the constructivist movement, and also those who value the latter stages of Perry's continuum, would argue that good teachers do not simply transmit information or content but they establish opportunities for the learners to construct their own knowledge and provide the potential for students to experience the plurality of the situation.

It might be argued that aspects of the subject areas under consideration in this study are based on a few truths and hence support the notion of duality. These include, for instance, the conservation equations of energy, momentum and mass. The pluralistic uncertainty in the subject areas arises more with the application of the truths and the assumptions being made in their application.

Work by Bransford, Brown & Cocking (2000) in their text on *How People Learn* highlight four different foci or 'centeredness's' that should exist in an environment to support learning; these being assessment, learner, knowledge and community centeredness:

- *Assessment centeredness* requires opportunities for the students' thinking and knowledge to be made visible, to themselves and their teachers, such that affirmations or corrections can be made.
- *Learner centeredness* seeks to establish an environment and associated activities that support the learners, their varied learning styles and their personal knowledge and skills base.
- *Knowledge centeredness* appropriately challenges the students to develop their thinking and understanding of the subject domain.
- *Community centeredness* seeks to establish a culture of sharing and peer support between learners, and also between teacher and learner.

The work also highlights the importance of so-called 'anchored instruction'. Anchoring the instruction on a topic or theme provides students with a concrete example on which to relate their learning.

A teaching strategy developed specifically to exploit the interconnected four foci of the How People Learn framework is the *Star Legacy Cycle*. The Star Legacy Cycle is also explicitly anchored around a *Grand Challenge* and includes five sequenced events; *generating ideas* (learner centred), *gaining multiple perspectives* (community centred), *undertaking research and revisions* (knowledge centred), *testing your mettle* (assessment centred) and *going public* (community centred). Application of the Star-Legacy Cycle can be found in (Birol, Liu, Smith, & Hirsch, 2006; Klein, 2006). Using the Star-Legacy Cycle, Cordray, Harris and Klein (2009) describe how the students benefit from engaging with a more structured and guided learning sequence.

There is much in the How People Learn framework that is consistent with the Conversational Framework offered by Laurillard (2002). In the Conversational Framework four components are identified as being important. These are the teacher's conceptions, the teacher's constructed environment, the students' conceptions and the students' actions. To support the students' learning, and the ensuing learning conversation, which is built on making the students' knowledge visible and available for teachers, Laurillard argues there is an explicit need for both teacher and student to discuss, interact, reflect and adapt.

Another teaching strategy that exploits many of the principles of the Conversational Framework is Just-in-Time-Teaching (JiTT) (Novak, Gavrin, Anderson, & Patterson, 1999). JiTT is based on the interaction between web-based study assignments and an 'active learner classroom', and explicitly seeks out the students' conceptions, between teaching sessions, via teacher constructed on-line activities. These conceptions are then taken back to class for further activity, exploration and/or to re-shape the upcoming lecture. Examples of JiTT and the purposive blend of on-line with conventional teaching and learning activities are reported in (Russell, 2006; Simkins & Maier, 2004).

The similarities between the Conversational Framework and JiTT are the explicit intent to establish a dialogue between teacher and student and that immediate teaching and learning adaptations are created as a consequence of the dialogue and the information flowing between teacher and student. Dialogic based teaching strategies note the importance of reflection and adaptation and hence locate the students and their current conceptions firmly within the learning design. Such student-centred learning environments are different from teaching strategies that focus on the curriculum content and subsequently do not fall foul of the observation that "*much the easiest mistake to make in deciding upon content and aims is to include too much detail*" (Ramsden, 1994, p. 137). An overly content-centric curriculum is likely to lead to inappropriate study behaviours and bring about a limited learning potential, as indicated in Table 2-1.

Two likely differences between a teaching (content) centred environment and a student (learning) centred environment are set out by Crawley *et al.* (2007). In a teaching centred environment the assessment activity is separate from the teaching whereas in the learning centred environment the assessment and teaching are intertwined.

It is apparent from the ongoing review that assessment too plays a significant part in promoting learning. Assessment provides opportunities for practice, to encourage active learning, to establish and make visible the students' conceptions and misconceptions and to generate feedback, all of which feature as important in many of the previously identified references. Assessment also impacts on the student's approach to learning. Given the importance of assessment and the direction of this research programme, the following section reviews assessment-focused literature.



#### 2.1.4 The purpose of assessment

The UK Quality Assurance Agency's (QAA) code of practice on assessment suggest assessment serves a variety of purposes (QAA, 2006). These include:

- Promoting student learning by providing the student with feedback, normally to help improve his/her performance.
- Evaluating student knowledge, understanding, abilities or skills.
- Providing a mark or grade that enables a student's performance to be established. The mark or grade may also be used to make progress decisions.
- Enabling the public (including employers) and higher education providers to know that an individual has attained an appropriate level of achievement that reflects the academic standards set by the awarding institution and agreed UK norms, including the frameworks for higher education qualifications. This may include demonstrating fitness to practise or meeting other professional requirements.

A similar yet shorter list is offered by Brown (2001) and comprises:

- to give a licence to proceed to the next stage or to graduation
- to classify the performance of students in rank order;
- to improve [the students'] learning.

Principally these and other suggestions around the purpose of assessment converge on notions that assessment can be viewed as being *diagnostic*, *formative* or *summative*. Diagnostic assessment looks for the students' preparedness for entering a module or programme. Summative assessment is typically conducted at the end of instruction, measures learning and records student achievement. Summative assessment has a purpose to grade students (Brown, Race, & Rust, 2005; Ebel & Frisbie, 1991; Gipps & Murphy, 1999). Formative assessment, on the other hand, specifically emphasises and accelerates the potential for learning created by the assessment tasks and the ensuing feedback. (Rolfe, 1995; Sadler, 1998) and spans a continuum from the informal to the formal (McAlpine, 2002; Rowntree, 1977).

The typical characteristics of both formative and summative assessments are given by Harlen & James (1997). For formative assessment these include its positive intent, the relationship of the assessment with learning and teaching, an emphasis on validity rather than reliability and the central role of the learner in the assessment processes. To note the positive relationship between formative assessment, learning and teaching, Wang (2007, p.

172) defines the purpose of formative assessment as “[to] illuminate learner difficulties and enhance teacher effectiveness”, and states that it “is always administered during the teaching process”. Summative assessment, according to the characteristics set out by Harlen & James (1997), takes place when achievement has to be reported, relates to progression against public criteria, involves aspects of quality assurance, and has an emphasis on reliability without compromising the validity of the assessment. Looking at these characteristics, there is a difference in emphasis from the assessment being oriented to supporting the students and their learning (formative assessment) against a process that is driven by a need to demonstrate accountability and transparency (summative assessment) to internal and external agencies. Quite simply, formative and summative assessment have different properties (Gipps & Murphy, 1999) and create different consequences.

To further promote the differences between the purposes and properties of formative and summative assessment, notions of assessment *for* learning, which is synonymous with formative assessment, and assessment *of* learning; synonymous with summative assessment, are also found in the literature. This alternative language, which essentially has the same meaning, is presented as being more accessible (Daugherty & Ecclestone, 2006). Assessment *for* learning is characterised by assessment tasks that focus on learning, is student and not content or teaching centric and allows students to show their misconceptions without fear of being punished. Assessment for learning is described by Black, Harrison, Lee, Marshall, & William (2008, p. 81) as a “*way of thinking, almost a philosophy*”.

Six principles guide the work of the *Assessment for Learning* CETL located in the University of Northumbria, UK (McDowell et al., 2006):

Assessment for Learning:

- Emphasises authenticity and complexity in the content and methods of assessment rather than reproduction of knowledge and reductive measurement.
- Uses high-stakes summative assessment rigorously but sparingly rather than as the main driver for learning.
- Offers students extensive opportunities to engage in the kinds of tasks that develop and demonstrate their learning, thus building their confidence and capabilities before they are summatively assessed.

- Is rich in feedback derived from formal mechanisms e.g. tutor comments on assignments, student self-review logs.
- Is rich in informal feedback e.g. peer review of draft writing, collaborative project work, which provides students with a continuous flow of feedback on 'how they are doing'.
- Develops students' abilities to direct their own learning, evaluate their own progress and attainments and support the learning of others.

The importance of the '*purpose*' of the assessment is affirmed by Wiliam & Black (1996, p. 538) when they write "*from the earliest use of these terms [formative and summative] it was stressed that the terms applied not to the assessments themselves, but to the functions they served*". As examples they offer "*on the one hand, the results of an assessment that had been designed originally to fulfill a summative function might be used formatively, as is the case when a teacher administers a paper from a previous year in order to help students to prepare for an examination. On the other hand, one does not have to go far to find examples of assessments intended to have some formative value whose results are used simply as summative judgments of the achievement of students*".

Accepting the importance of the purpose to which the assessment is put suggests their different features characterise the different purposes of the assessment; a suggested outline is given in Table 2-3.

Table 2-3 Suggested features of formative and summative assessment

	<i>Formative assessment</i>	<i>Summative assessment</i>
Principal focus	<i>Learning</i> , by providing the students with a safe space to practice.	<i>Grading</i> , and establishing the students' demonstrable ability to meet the learning outcomes.
Stakes	No / low stakes. These assessments are non-judgemental and students are free, indeed encouraged, to show their misconceptions of the topic area without suffering detrimental consequences to their grades or their potential to progress / graduate.	<i>High stakes</i> . These assessments are likely to impact on the students' ability to progress and ultimately their degree classification. Assessments of learning are judgemental and are therefore likely to influence the students' willingness to share their misconceptions of the topic
Timing	<i>Embedded</i> within the ongoing learning events. In many cases they are integral to, and important components of, the learning events.	<i>End of learning event</i> . In such situations the students may have moved away from that topic area and are now focusing on other areas.
Provision of feedback	<i>Feedback rich</i> which enhances the learning by correcting, confirming and encouraging. Good assessment for learning will actively encourage students to use the feedback for their progression and educational growth.	<i>Feedback poor / absent</i> . This suggests, along with issues of its timing, that the potential for students to learn from the limited feedback is reduced / non-existent.
Additional consequences	Can stimulate meta-learning and long term learning. Offers the potential to create assessments that support a deep approach to learning.	Likely to promote short term learning strategies. May create anxiety and inadvertently create a surface approach to learning
Key beneficiaries	<i>The individual students</i> . The focus is on improvement and student learning. Teachers wishing to draw on the students' understandings will also benefit from the orientation of the assessment.	<i>Administrative offices</i> . The collection of student scores will inform on the ability to progress / graduate the students. This information is useful in ranking universities too. Processes can be viewed against assessment regulations.

While it might be argued that an assessment task could reasonably be a mix of both formative and summative assessment, e.g. a mid-semester assessment that makes a significant contribution to the students' grade, with feedback provided in a timely fashion such that students can use it to enhance their learning, the dual purpose is not ideal. The

focus of the assessment, as suggested in Table 2-3, implies students come to the different assessment types with different intentions.

Drawing on Table 2-3, and using the example of the end of year examination paper offered by William and Black (ibid), there is a need to do more than re-title the old summative assessment to create a more formative variant. Putting the old summative assessment to its new formative purpose provides a rich opportunity for feedback, allows the students to safely explore their knowledge without penalty and is lower in both its stakes and the subsequent stress it might cause the students. Such features are unlikely to exist with the summative version and so the re-use of a summative assessment in a formative context will demand additional design and perhaps the creation of new resources and/or teaching and learning settings.

While compartmentalising the purpose of assessment is essential in articulating and describing its major intention to the students, the boundary between formative and summative assessment is not always clear cut (Rowntree, 1977). Assessment is, as (Ramsden, 1994, p. 182) suggests, “*about several things at once*”. This blurring-of-the-boundary is picked up by Yorke (2003, p. 479) when he suggests that “*some assessments (e.g. in course assignments) are deliberately designed to be simultaneously formative and summative; formative because the student is expected to learn from whatever feedback is provided, and summative because the grade awarded contributes to the overall grade at the end of the study unit*” [emphasis added]. As indicated above, a lack of distinction between the purposes of assessment is problematic since not only may the purposes of assessment overlap but they may *conflict* (G. Brown, 2001). Indeed Brown also notes that “*a common error is to use an assessment task for one set of purposes and then assume that the results from it are appropriate for other purposes*” (ibid, p. 6). The observation made by Yorke is troublesome since the potential for learning can be enhanced if the students are able to articulate their understanding of the subject/topic and in doing so, knowingly or otherwise, highlight their gaps and misconceptions.

The students are more likely to share their misconceptions if tasks do not create the potential for negative consequences. This situation is more likely to arise with the use of low- or no-stakes formative assessment and motivating students by intrinsic learning goals such as the desire to learn and an enjoyment of the subject, and not by extrinsic goals such as grades (Knight, 2001).

An extensive review of formative assessment practices in a range of settings including schools and universities, and across subject areas, has been undertaken by Black & William (1998). The review, *Inside the Black Box: Raising Standards Through Classroom Assessment*, like its 'control systems' counterpart suggests the black box has inputs and outputs. The inputs are offered as "*the pupils, teachers, other resources, management rules and requirements, parental anxiety, standards and tests with high stakes*". The outputs being "*pupils that are more knowledgeable and competent, better test results and teachers who are more or less satisfied, and more or less exhausted*" (ibid p. 1).

The overwhelming output from Black and William's review is that formative assessment has the potential to play a significant part in supporting learning and that formative assessment is at the heart of good teaching. However, as Yorke (2003) discusses, there are a number of issues and challenges pervading Higher Education that he argues are threatening the use of formative assessments. These are listed as:

- An increasing concern with attainment standards, leading to greater emphasis on the (summative) assessment of outcomes.
- Increasing student-staff ratios, leading to a decrease in the attention being given to individuals.
- Curricular structures changing in the direction of greater unitisation, resulting in more frequent assessments of outcomes and less opportunity for formative feedback.
- The demands placed on academic staff in addition to teaching, which include the need to be seen as 'research active', the generation of funding, public service, and intra-institutional administration.

A rallying call by an international expert group on assessment produced an assessment manifesto to reinvigorate the use of assessment *for* learning without compromising the importance of any assessment *of* learning. The six tenets of the manifesto are oriented around assessment *for* learning, active engagement in assessment standards and developing situations where appropriate dialogue can flourish (Weston-Manor-Group, 2007).

Observations into the broader issues of assessment on learning are offered by Messick (1999). Messick argues that assessments are not just about test scores or the intended consequences, but also create unintended consequences. The validity of the intended and unintended consequences is referred to by Messick as the consequential validity. Recognising that assessment has many meanings and creates differing consequences, as implied by notions of consequential validity, is affirmed by Boud (2000, p. 159) when he

introduces notions of double-duty. Boud writes “*an assessment act is never only what it appears or what we think it to be. It is always part of a broader discourse and has wider significance beyond the immediate context. We need ways of reminding ourselves about this so that we do not pretend that assessment practices only perform the immediate function desired by those who design assessment tasks*”.

### 2.1.5 Assessment and learning

Irrespective of its purpose, assessment has repeatedly been recognised as being dominant in indicating to the students what is important and what is not. This point is raised by Ramsden (1994, p. 187) when he suggests “*from our students’ point of view, assessment always defines the actual curriculum*” [emphasis added], Rowntree (1977) refers to assessments creating the *de facto curriculum*, and Snyder (1970), following interviews with students, identified the notion of a *hidden curriculum*. The hidden curriculum differs from the formal curriculum, is influenced significantly by the assessment regime and hence reinforces the previously introduced ideas of consequential validity and double-duty. As an example of the hidden curriculum Snyder observes one professor explaining to his students “*that they were expected to be creative and involved: In short they were to be active. They would have the opportunity to take intellectual risks and make mistakes*” (ibid, p. 16). Five weeks after the introduction the professor presented a quiz, that “*required the students to return a large amount of information that they could have mastered by memorisation*” (ibid p. 17). There was clearly a misalignment between the rousing introduction and the set assessment task. The misalignment was picked up by the students and although many appeared to be relieved to find that rote memory would suffice it seems all notions of stimulating risk taking and developing creativity were lost.

Examples of the influence of assessment on students’ interpretation of the curriculum and its influence on their study behaviours is given by Biggs (2003) when he refers to the *backwash of assessment*. Features of this inescapable backwash of assessment include the apparent cues it gives to students about;

- when they need to pick up their books and when they don't;
- how they need to distribute the effort across the topic areas;
- whether they need to think about the topic area at the micro or macro level;
- whether their knowledge base needs to remain situated in their discipline area or become abstracted beyond it.

The importance of assessment on students' behaviours is emphasised by Gibbs (1999, p. 124), who, when referring to some UK diary studies, notes how they [the diary entries], *"confirmed the extent to which students devote their out-of-class study time almost exclusively to assessed tasks. Take away the assessment and you lose the effort and the learning"*.

Aligned teaching is a designed function that recognises the influence of assessment and purposely creates a learning environment that includes the assessment tasks (Biggs 2003). The purposive inclusion of assessment helps ensure that the students' activity is aligned with the intended learning outcomes and the backwash of assessment creates positive consequences for learning. By definition, in aligned teaching, the assessment is seen as an integral component of the curriculum and not the add-on or after thought which, according to Heywood (2000), it too often is. After reaffirming the importance of assessment as an integral component of the teaching and learning system [aligned teaching], Wakefield (2007, p. 42) suggests that *"assessment may be used explicitly to guide students in their study"*. He goes on to say that *"what is rewarded and ignored by more formal examinations will have a substantial impact upon their [the students'] learning behaviour and thus upon the outcomes of a course"*.

Clearly, tasking students through assessment in an aligned curriculum is likely to lead to a closer agreement between the students and their teacher as to what constitutes the actual curriculum. However, while aligned teaching integrates teaching, the learning environment and the assessment activity, they are not of equal importance. Although offering the benefits of aligned teaching, Biggs (2003, p. 165) himself notes that *"assessment is the senior partner in learning and teaching; get it wrong and the rest collapses"*.

It is not just the assessment task that creates learning but the messages, implicit or explicit, they provide to the students. Snyder's example of the professor trying to establish a risk taking and creative learning environment which was undone by his misaligned quiz is a case in point. Further, there can be little benefit in seeking to establish a learning environment that sets out to engage the students in the entire curricula and then providing a single assessment task towards the end of the module. According to Ramsden (1994) *"the methods we use to assess students are one of the most critical of all influences on their learning"*. Brown, Bull & Pendlebury (1997) reinforce the point when they write *"if you want to change student learning then change the methods of assessment"*. Both Ramsden and Brown *et al.* suggest that 'inappropriate' assessments are likely to lead to inappropriate influences on students' learning and study behaviours; a point which is particularly



problematic since assessment affects so many students and, as Boud reminds us, “[while] students can with difficulty escape from the effects of poor teaching they cannot (by definition if they wish to graduate) escape the effects of poor assessment” (Boud, 2005, p. 35).

An instrument specifically developed to look at the ability of an assessment task to promote learning is the Assessment Experience Questionnaire (AEQ) (Gibbs & Simpson, 2004). The AEQ highlights 11 conditions, clustered into six themes. These themes are concerned with the quantity and distribution of student effort; quality and level of student effort; quantity and timing of feedback; quality of feedback and the student’s response to the feedback.

The following section takes a steer from the AEQ and explores the importance of feedback within the assessment process.

#### 2.1.6 Assessment and feedback

The noticeable importance of feedback, in that it features in three of the six themes of the AEQ, suggests that good assessments do not just commit the students to action but they typically commit their assessors too. Assessing students is a demanding activity. It requires the assessor to understand the intentions of the assessment activity, to appreciate what students have done well, to identify what students have done less well and indicate what the students might do to improve their work. Such activity (assessing student work) presents a great opportunity to engage students in the assessment-*for-learning* tenets offered by the Weston-Manor-Group (2007). It is unfortunate, therefore, that despite the numerous reported benefits to be realised in adopting peer and self assessment it appears that the predominant approach to the assessment of students’ work remains tutor led (Fallows & Chandramohan, 2001).

Irrespective of who is providing it, the feedback should be viewed as an integral part of the assessment process since it allows the students’ work to be evaluated, thus creating opportunities to provide support, encouragement and guidance. In some cases the guidance might be viewed as confirmatory whereas in other cases it might be corrective. The intended consequence of feedback is to improve learning. Huxam (2007, p. 601), writes “*feedback to students is essential for effective learning*”; a point which is reinforced by Orsmond, Merry, & Reiling (2000) when they suggest tutor feedback is inseparable from the learning process and although student activity is repeatedly raised as being important for learning “*action without feedback is completely unproductive to a learner*” (Laurillard, 2002, p. 61). In the

case of assessment, the action is the students' engagement with the assessment task. Clearly, if assessments are as influential on the students' learning as the literature suggests then that influence can be enhanced by providing appropriate and timely feedback.

Given the noted importance of feedback, the integral part it plays with assessment, its relationship with learning and the guidance relating to timely feedback, it is disappointing to note the results of the recently introduced National Student Survey (NSS). The NSS is a UK initiative with an aim "*to gather feedback on the quality of students' courses, to help inform the choices of future applicants to higher education, and to contribute to public accountability*" (HEFCE, 2005). Using a five point rating scale, the student view is obtained by their response to a 22 closed-question, seven-theme questionnaire. The themes of the questionnaire are; the teaching on the course; assessment and feedback; academic support; organisation and management; learning resources; personal development; and overall satisfaction.

The students' responses are tied to their specific subject area and their own university. In the section *assessment and feedback* the students are asked to respond to five statements:

- i) The criteria used in marking have been clear in advance.
- ii) Assessment arrangements and marking have been fair.
- iii) Feedback on my work has been prompt.
- iv) I have received detailed comments on my work.
- v) Feedback on my work has helped me clarify things I did not understand.

An exploration of the Unistats database (Unistats, 2007), which stores NSS scores, will show that in many cases assessment and feedback is rated the lowest of the seven themes. Further, within the Assessment and Feedback theme, response to the question '*feedback on my work has been prompt*' often scores the lowest mark.

An article in the Times Newspaper (Freen, 2006, p. 26; Light & Cox, 2001) regarding the NSS results quips that "*they [the teachers] expect their students to hand their essays in on time and write coherently, but England's university teachers are pretty poor at meeting deadlines or explaining difficult concepts. Only 51 per cent provided prompt feedback to their students last year, and the same percentage were able to clarify things their students did not understand, according to the second National Student Satisfaction Survey*".

There is an apparent disconnection between what the research tells teachers about the value of prompt feedback and how students perceive their teachers' actions in providing the feedback. On one hand the disappointing NSS scores are to be expected if the nature of assessment practice in Higher Education dictates that feedback is provided too late for it to be effective and subsequently used by our students (Carless, 2006; Light & Cox, 2001; Race, 1998). Although Gosling (2007, p. 172) writes "*a not-uncommon fault in a semester system is that students only find out how well, or how badly, they are doing when they receive their assessed work and by that time it is too late to take remedial action*", he also goes on to suggest that "*from the tutor's point of view it is difficult to give formative feedback to large classes in the short time available*". The relationship between teacher workload, increased volumes of marking and reduced quality and timing of feedback is also raised by Glover & Brown (2006).

Whilst the demands placed on teachers impacts on the quality and timing of feedback, the results of the NSS might also indicate a need to inform and better educate students with respect to what actually constitutes feedback. Feedback should not be viewed as the closing comments or grade placed at the bottom of an essay. Feedback also includes model answers, hints and tips as well as the information that flows from teacher led discussions and peer dialogue around the assessment activity (Race, 2001).

#### 2.1.6.1 Effective feedback

A checklist of effective feedback practice is given by Rust (2002). It is suggested here that Rust's 15 items could be compartmentalised into four themes; a positive focus; suggesting where next; making connections with the students; and offering justification. The items, in the 'suggested' categories, are given below.

A positive focus:

- start off with a positive, encouraging comment;
- balance negative with positive comments;
- turn all criticism into positive suggestions.

Suggesting where next:

- make general suggestions on how to go about the next assignment;
- suggest specific ways to improve the assignment;
- suggest follow-up work and references;
- ask questions which encourage reflection about the work.

Making connections with the student:

- be prompt;
- use informal, conversational language;
- offer help with specific problems;
- offer the opportunity to discuss the assignment, and comments.

Offering justification:

- explain all your comments;
- include a brief summary of your view of the assignment;
- relate specifically to the learning outcomes and assessment criteria;
- explain the mark or grade, and why it is not better (or worse!).

While offering the checklist Rust offers a word of caution when he writes “*although feedback which follows these guidelines, is likely to be better than nothing, sadly research evidence would also suggest that just giving feedback to students without requiring them to actively engage with it is likely to have only limited effect*” (ibid p. 158). It seems that just as learning requires action so there exists an additional potential for learning if the students are required to actively engage with the feedback. Or, put more starkly, the provision of feedback is unlikely in itself to lead to learning. Students need to engage with and act on the feedback they receive (Gibbs & Simpson, 2004). Sadler (1998, p. 78) suggests that “*students should also be trained in how to interpret feedback, how to make connections between the feedback and the characteristics of the work they produce, and how they can improve their work in the future. It cannot simply be assumed that when students are 'given feedback' they will know what to do with it*”. This suggested need to train students to interpret the feedback partly resonates with the previous suggestion that there might be a need to educate students as to what actually constitutes feedback.

Nicol & Macfarlane-Dick (2006) specifically focus on feedback when they offer their *Seven Principles of Good Feedback Practice*. They suggest that good feedback:

- helps clarify what good performance is (goals, criteria, expected standards);
- facilitates the development of self-assessment (reflection) in learning;
- delivers high quality information to students about their learning;
- encourages teacher and peer dialogue around learning;
- encourages positive motivational beliefs and self-esteem;
- provides opportunities to close the gap between current and desired performance;
- provides information to teachers that can be used to help shape the teaching.

The *Seven Principles* developed by Nicol & McFarlane-Dick (2006) have subsequently been developed to form *12 Principles of Good Assessment and Feedback Practice* (Nicol, 2007). Naturally there is some overlap with the original work but the addition of assessment (to the original focus on feedback) has prompted additional principles associated with giving learners choice in assessment, involving students in decision-making about assessment policy and practice, using the assessment activity to help support the development of learning communities, and ensuring that the assessment encourages 'time and effort' on challenging learning tasks.

#### 2.1.6.2 Use of feedback

Previous sections of this thesis have indicated the importance of feedback and the support it provides to the assessment and learning activity. One of the concerns over summative assessment and its limited relationship to learning is reinforced by Bransford *et al.* (2000, p. 140) when they write "*opportunities for feedback appear to occur relatively infrequently. Most teacher feedback – grades on tests, papers, worksheets, homework... represent summative assessments that are intended to measure the results of learning. After receiving grades, students typically move on to a new topic and work for another set of grades*". Feedback should not only consolidate students' recent engagement with the assessment task but should also stimulate additional activity. To demonstrate the idea that learning is enhanced when feedback is used, Bransford *et al.* go on to write "*feedback is most valuable when students have the opportunity to use it to revise their thinking as they are working*" (ibid 129). In essence good feedback and assessment practice will create a cycle of student reflection, leading to future planning and action. In the case of the Fluid Mechanics and Thermodynamics phase test, there was little (if any) chance for the students to engage with the feedback. Such situations are probably not unique. Poulos & Mahony (2007, p. 144), for instance, write that "*most of the research on feedback to student has focused on the input side of the equation, what is provided to students, how it is provided and when*". They go on to say that "*how the student interprets and deals with feedback is critical to the success of formative assessment*". Feedback should, as the assessment task does, create student activity. The importance of feedback and its relationship with future learning is noted in the guidance given by the QAA to Higher Education Institutions (HEi's) when it suggests "*institutions should provide appropriate and timely feedback to students on assessed work in a way that promotes learning and facilitates improvement ...*'

Reporting on their Formative Assessment in Science Teaching (FAST) project, Glover & Brown (2006, p. 2) note that "*supported by external examiners' reports and subject reviews, tutors at Sheffield Hallam University (SHU) argued that they were providing high quality*

*feedback, but that much of this was neither engaged with, nor acted upon, by students*". Higgins, Hartley & Skelton (2001, p. 272) report "*there is certainly research evidence to suggest that even if students do read comments they do little with them*". A point reinforced by Gibbs & Simpson (2004) when they include in their AEQ the need for feedback to be attended to by the students. In attending to the feedback the students will also be presented with an opportunity to *close the gap between current and desired performance*, a suggested principle of good feedback practice (Nicol & Macfarlane-Dick, 2006).

Specific examples of assessment strategies that explicitly require students to engage with feedback include the *Test Analysis* (Carter, 1998) and the *Zero Tolerance* (Reynolds, 2004) assessment strategies. In Carter's example the students' completed mathematics assignments were returned with each question noted as being correct, having a minor error or having a major, usually conceptual, error. In all cases the students were required to engage in follow-up activity responding to the limited feedback, namely the Test Analysis. For each error the students were required to write a description of what the error was and why it was likely to have arisen. They were also required to correct the error and demonstrate their new found understanding. For assignments with little or no errors the students were required to write a written response describing what they found the easiest concept to master and the most challenging on the assessment. All students, therefore, were subsequently challenged with follow-up activity. The students' final grade comprised their initial submission and their response to the Test Analysis. The approach was clearly oriented around developing autonomous learners and according to Carter amounted to shifting the responsibility for learning back to the student. Reynolds, on the other hand, requires his civil engineering students to re-submit their work, drawing on the feedback, if their original submission did not meet a pass standard. Reynolds refers to this as a Zero Tolerance assessment strategy. The final coursework grade is a function of the number of opportunities the student has taken to achieve the pass criteria. While the notion of a Zero Tolerance Assessment Strategy conflicts with advice regarding a safe learning environment, for example; "*we need to ensure, as much as possible, that the workload expected of students is realistic, and that the assessment system is non-threatening and non-anxiety provoking*" (Rust, 2002, p. 149), given the safety-critical nature of the subject and the real world consequences of making mistakes, such an approach might be justifiable and have its proponents.

Another example requiring students to engage with the feedback is presented by Higgins & Hartley (2001). Higgins & Hartley re-conceptualised feedback as 'feed-forward'. That is, the information that flows back to the students is used by them to plan and be demonstrably

used in subsequent assessment tasks. The value of conceptualising feedback as being useful to future tasks is affirmed by Carless (2007) in one of his three principles of Learning Oriented Assessment. His third principle suggests “*feedback should be timely and forward-looking so as to support current and future student learning*” (ibid p. 60) [emphasis added].

This demonstrable use of feedback may help to overcome the problem noted by Duncan (2007) when he suggests “*tutors become used to repeating important advice to some students, with no evidence that they have read, understood, or learned from the points raised by them*”. Feed-forward and formative assessment strategies that require the students to draw on the feedback creates additional consequences. Indeed, according to Black & Wiliam (1996, p. 536), “*formative functions of assessment are therefore validated in terms of their consequences as much as their meaning*”. In addition to the provision and promptness of feedback it is apparent that students’ learning is enhanced if they actively engage with the feedback.

### 2.1.7 Regular assessments

The preceding discussions have shown that assessments are significant in supporting student learning. Good assessments engage students in relevant activity, provide opportunity to practise, and stimulate appropriate study behaviours. Good assessments demand the attention of the teachers (assessors) too. It is the teachers who typically create, assess and provide the feedback on students’ work. Further, feedback that is prompt, encouraging and requires additional student action is likely to enhance the students’ learning. Hence, rather than viewing the act of assessing and provision of feedback as a burden, it is worth noting the observations by Yorke (2003, p. 482) when he points to the resultant gains for the teachers; “*the act of assessing (formally and informally; formatively and summatively) has an effect on assessors as well as on students. Assessors learn about the extent to which students have developed expertise, and can tailor their teaching accordingly.*” Good assessments, therefore, create a valuable learning experience for the teachers as well as the students.

Given the opportunities that assessment offers teachers to learn about their students; a significant and recurring theme in the work of Rowntree (1977); it is surprising that regular or continuous assessments are not used more often. By definition, less assessment is likely to lead to less opportunity for feedback. This, in turn implies a reduced potential to get to know our students, limited evidence on which to base teaching adaptations and ultimately a reduction in the potential for learning. Hence, just as the NSS scores indicate a potential

disconnection between theory and practice in the area of feedback, so there also appears a disconnection between the recognised value of regular assessments and their use in practice to support the teaching and learning transactions.

The immediate benefits of continuous assessment over terminal assessments are twofold. First, the potential to heighten the consequential validity by actively encouraging the students to distribute their efforts across the topic areas. And second by engaging regularly with their studies which ultimately reduces the potential for cramming. This relates to the time on task principle (Chickering & Gamson, 1987; Gibbs & Simpson, 2004). Cramming is a learning trait that is likely to lead to an inappropriate surface approach to learning. Haigh's (2007, p. 458) reason for introducing weekly test quizzes reinforces this view, his justification being "... to try to foster student learning, increase student engagement and help remove dysfunctional study patterns." Haigh also notes that the teachers benefit by making the students' conceptions and misconceptions visible to all parties. This flow of information provides the evidence with which to make informed teaching adaptations. This is particularly important for teaching strategies based around Just-in-Time-Teaching (Novak *et al.*, 1999) or the Conversational Framework (Laurillard, 2002) since they, by definition, rely on such information to help shape the teaching sessions.

Isaksson (2007) used *five minute essays* set at the end of each week's lecture. These essays were presented as being part of the in-course assessment. They were tutor marked and implemented to "*increase the students' engagement at each lecture and to catch their attention*" (ibid p. 2). Although some of the students commented that the experience was stressful, other comments are more positive and are aligned with the original motivation for including the tests. One student writes that "*It [the essays] makes it difficult to get a free ride*", and another writes that "*it, [the essays], increases attention during lectures*" (ibid p. 6). Importantly, Isaksson suggests the students' performance on the essays improved as the weeks went on.

Regular assessments, although often shorter than their one-off counterparts, are generally more resource intensive. For regular assessment activity, the attendant processes of administering, collecting, assessing, providing feedback and redistributing the continuous feedback to the students are not trivial. The following section therefore reviews issues around resource efficiency.



### 2.1.8 Resource efficiency

In addition to reviewing and ensuring the educational value of the assessment activity there is a need to ensure that they are not overly burdensome for the teachers. There can be little benefit in creating assessments that are aligned with the intended learning outcomes and encourage the students to adopt a sophisticated and integrative approach to their studies if they also place unreasonable demands on the teacher to assess and provide the much needed feedback. According to Gibbs & Simpson (2004, p. 8) “*the trick, when designing assessment regimes, is to generate engagement with learning tasks without generating piles of marking*”. Yorke (2003, p. 483) further captures the need for resource efficiency when he writes “*a major challenge for higher education is to respond to the main 'message' of Black and Wiliam's review (formative assessment is, after all, a key tenet of good teaching) whilst accepting that it cannot revert to a perceived previous 'golden age' when student learning was better resourced.*”

A two-dimensional grid locating assessments in terms of their likely educational effectiveness versus the associated resource efficiency is offered by (Hornby, 2005) - see Figure 2-1.

Figure 2-1 Graph of educational effectiveness and resource efficiency

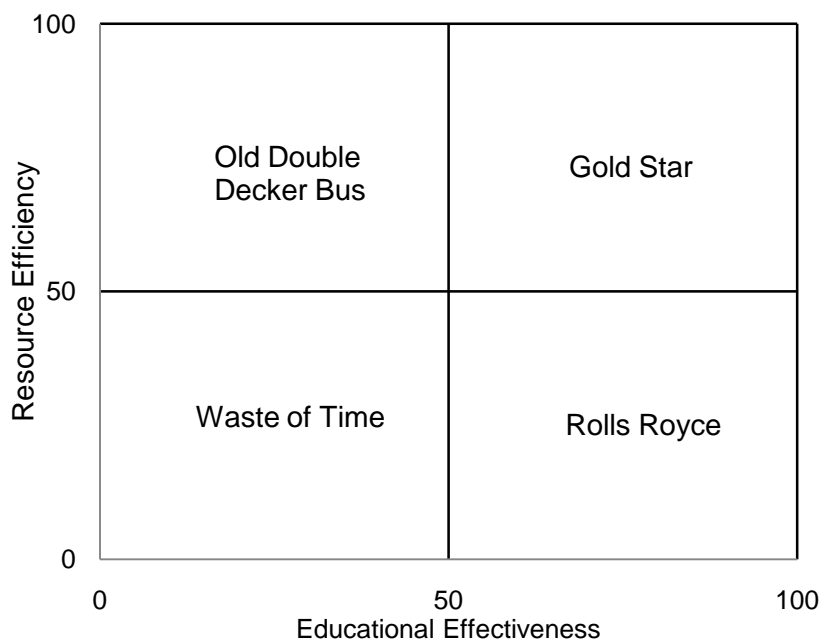

Source (Hornby, 2005)

Although the axes are presented as continua, the grid is compartmentalised into four distinct categories or regions. These four regions are termed *Gold Star*, *Waste of Time*, *Old Double*

*Decker Bus* and *Rolls Royce*. The Gold Star, as implied by its name, characterises assessments that are both highly educationally effective and resource efficient. The Waste of Time is diametrically opposed to the Gold Star and characterises assessments that offer limited educational value while placing high demands on the available resources. The Old Double Decker Bus represents assessments that offer limited educational value but place limited demands on the resources. Rolls Royce assessments, on the other hand, are highly educationally effective but are extremely resource intensive. An alternative classification is described by Lines & Gammie (2004). In the Lines & Gammie classification the Old Double Decker bus is replaced with a Fast Food Burger and the Rolls Royce replaced with a Persian Cat. The Fast Food Burger represents a cheap (resource-wise) yet non-fulfilling assessment activity. The Persian Cat, on the other hand, represents a highly educationally effective assessment task but one that requires a lot of interaction and is hence resource inefficient. Race (2005a) also offers a two dimensional grid on which assessments can be located (feedback efficiency and learning payoff) and also offers a rating system in which to establish the likely location of the assessment task on the grid.

The evidence on feedback and its potential to support learning dictates that carefully constructed feedback that takes too long to create and pass back to the students is unlikely to be as useful as less well prepared feedback that reaches the students soon after they engage with the assessment. This so-called *quick and dirty* feedback implies that the actions of the teachers, as well as the merits of the assessment *per se*, also locate the assessment task on the effectiveness versus efficiency grid. It is, therefore, the entire assessment *experience* that locates the task on the grid and not just the nature of the task.

The introduction of peer marking of homework sheets within an engineering module is described by Forbes & Spence (1991). Prior to the introduction of the peer marking activity the teachers implied they only had an impression of the amount and quality of work the students were doing after the mid-term examination was completed. Although the mid-term test would have illuminated poor performance and indicated a need to re-adjust student effort, students with poor performance struggled to redeem the situation in the second term. Given the teachers' concerns over their students' effort coupled with the resulting poor performance in the final examination, the students were subsequently required to engage in weekly activity. Further, the students were required, in class, using model solutions, to mark their peers' weekly submissions. The motivations behind the changes were two-fold. First, to redistribute the students' efforts across the weeks and topic areas, i.e. consistent with the benefits suggested by proponents of regular assessment activity, and second, to maintain the efficiency of the assessment activity by keeping the teachers away from the marking.

The set of final examination grades were higher than previously observed and the students now, according to Forbes & Spence, will take their newly-learned study habits to other subject areas. A similar peer marked weekly assessment scheme is reported by King & Gray (1991). They also talk of their desire to encourage even paced study and reduce the emphasis and burden of the final examination. In the King & Gray example 'markers and checkers' were used to undertake the marking activity. King and Gray also indicate an improved student examination performance but also, due to the use of markers and checkers, note the benefits of requiring students to justify their marking decisions. In addition to the educational benefits of the peer marking activity, both Forbes & Spence and King & Gray note that a major driver behind the peer marking activity was a desire to minimise staff time.

Russell (2005) presents another example of a 'possible' gold star where his students mark their peers' laboratory reports. This is undertaken using pre-defined marking criteria and includes questions relating to the presentation and the content of the laboratory report. In addition to the effectiveness gains, the teacher is no longer burdened with marking the 150 laboratory reports. The students themselves also report the positive impact of this approach to assessment on their learning. Similar examples of peer assessment are offered by Hughes & Large (1993).

The three examples quoted provide i) prompt feedback, ii) an opportunity for the students to see how others tackle the same task and iii) a transparency of marking as well as drawing the students closer to assessment criteria; all of which are suggested in the literature as being supportive of student learning. Further, the act of engaging students in peer assessment is also likely to stimulate self-reflection; a point also raised in Nicol & MacFarlane-Dick's (2006) *Seven Principles* and a central theme in the application of self-assessment, which included group discussions leading to peer feedback, reported by Taras (2001).

In addition to enhancing the effectiveness of the assessment process, the ability to enhance the efficiency of the process is often cited as a reason for using computers. The following section reviews the role of computers relevant to this research and the range of assessments to which they are typically applied.

### 2.1.9 The role of technology in assessments

Given that information and communication technology (ICT) is ubiquitous, it is of little surprise that it pervades education too. In 1997, The Higher Education Funding Council For England (HEFCE, 1997) wrote about the possibilities for ICT in education; *“in the present context of financial stringency and greatly increased numbers of students entering HE, the maintenance of quality in the face of reduced units of resource is something to which technology assisted teaching might contribute”*. Thoennesen & Harrison’s (1996) suggestion that the use of computers was already widespread indicates that their contribution was already being observed. The contribution of ICT has progressed rapidly since 1996 and there has been a vast increase in the use and sophistication of ICT to support teaching, learning and assessment processes. Hartley & Collins-Brown (1999) suggest that *“advances in technology are making an increasing impact on educational curricula, learning materials and instructional practices”*. They go on to say that *“these [ICT] developments are moving apace at a time when many societies are seeking to widen access to Further and Higher Education”*.

In many cases the use of educational technology manifests as managed or virtual learning environments (MLE/VLE’s). MLE’s are integrated intranet facilities that generally include the ability to:

- post news items;
- provide module notes and related web links;
- hold asynchronous and sometimes synchronous discussions;
- give students an opportunity to engage in web-logging (blogging) and wiki activity; and,
- provide on-line quizzes and/or tests.

These facilities are typically combined to provide a personalised student portal organised around the student’s individual programme of study. In many cases the use of the MLE appears to be focused on the provision of a central repository of learning resources. The central repository provides a virtual resource that seeks to draw students back to a virtual space. In doing so an additional connectivity is established between the teacher and the students as well as helping to connect the students to each other. This additional connectivity allows the students to be engaged outside the physical synchronous classroom and be kept up-to-date with module administration matters and learning activities in a supported virtual, but typically asynchronous, classroom.

A framework for the pedagogical evaluation of virtual learning environments is offered by Britain & Liber (1999). Three reasons for wanting to understand MLE's are listed by Pettit & Mason (2007). These include the institutional push, curiosity and a desire to develop teaching. Within the third reason they invite their readers to think how the MLE might facilitate learning that is different from that possible in a face-to-face session and also how the MLE will dovetail with other elements of the course, including the demands of the assessment. There is a clear suggestion in their writing that the MLE has the potential to support and enhance the traditional face to face teaching settings. General advice on using ICT and MLE's to support the *Seven Principles of Good Practice in Undergraduate Education* is given by Chickering & Ehrmann (1996), and specific examples of MLE's being used to support learning within engineering modules include (Bullen & Russell, 2007; Laws, 2005; Nortcliffe, 2005).

In addition to the use of MLE's to support teaching and learning, there exists an increasing use of ICT to support the assessment processes within HE. The growth and sustained interest in the use of ICT in assessment is evidenced by the annual International Conference on Computer Assisted Assessment (CAA) which, in 2009, was in its thirteenth year. There also exists a wealth of texts and journal articles dealing specifically with CAA. Many of the examples of CAA appear to be oriented around the use of objective tests. These include guidance notes on establishing good objective tests (Pritchett, 1999), experiences of using objective tests and suggestions on analysing the items (questions) of the objective test (Bull & McKenna, 2004).

While Brosnan (1999) suggests that CAA is essentially unchecked, the technology provides opportunities to undertake additional analyses of the outputs. These outputs include both the performance of the students as well as the performance of the assessments and their constituent questions. This point is supported by Conole & Warburton (2005, p. 26) when they write "*one of the benefits of CAA is the opportunity to record student interactions and analyse these to provide a richer understanding of learning*". They go on to say; "*a variety of analyses can be run to assess how well individual questions or students perform. Weak items can then be eliminated or teacher strategies adapted.*" It is not obvious if paper-based assessments are exposed to the same level of interrogative rigour. A useful side-effect of using ICT in the assessment process is the ability the technology provides to check itself.

Objective tests, which appear to be the most common form of CAA, are constructed from questions that are typically convergent; that is, they have a correct answer. Although QuestionMark Perception (QMP, 2007), a propriety objective test client, facilitates the use of

22 different question types, according to Warburton & Conole (2003) the majority of objective tests comprise either multiple-choice questions (one correct answer chosen from a predefined list of distractors) or multiple-select questions (more than one correct answer chosen from a predefined list of distractors). The limited use of the available question types is reinforced by Bennett & Nuthi (2008). After a review of QMP database storing 2323 questions, coincidentally running at the University of Hertfordshire, Bennett & Nuthi found that 66% of the questions were multiple-choice questions. They go on to show that 80% of the questions stored in the database were of three types, multiple-choice, fill-in-the-blank and multiple-select.

The high use of multiple-choice questions in lieu of other question types is of little surprise since, according to Berk (1998, p. 93), *“the multiple choice test item format provides the “best buy” for content coverage, administration, scoring and reliability in large classes (greater than 30)”*. While the objectivity of the tests suggests they are highly amenable to computer exploitation, they are still the subject of much scrutiny and criticism. Berk himself teases that multiple choice questioning *“holds world records in the category of most popular, most unpopular, most used, most misused, most loved and most hated test item format”*. Miller & Parlett (1974, p. 27) talk about MCQs being the *“least complex type of task”*. They go on to say that *“the most complex aspects of the task have been taken over by the examiner in setting it”*. Heywood (2000, p. 365) points out that *“apart from the issue of guessing, the most often-used objection to objective items is that they only test recall of knowledge”*. Heywood continues; *“or to put it another, more cogent way, they do not test reasoning”*. Davies (2001, p. 1) notes that *“the criticism offered by CAA sceptics is we are not developing transferable skills. Students on leaving higher education will rarely be expected to produce answers for their employers that require multiple choice skills, but will be expected to produce reports, presentations, etc.”* Although Davies points to sceptics of CAA, the criticism is more appropriately levelled at the objective test, which could equally be paper based as well as being deployed on a computer. The use of the computer does not fundamentally change the nature of the test; it simply modifies the mode of student engagement. Davies, in his 2001 paper, offers the use of computers to facilitate peer assessment and hence extends the use of computers for assessment beyond objective tests. The peer review brings subjectivity to the assessment and the use of ICT brings a visible and traceable dialogue between the participants of the peer review process.

A later paper (Davies, 2002) showed how the use of multiple choice questions might be enhanced by the use of confidence levels. Tests using confidence levels gather not only the students' responses to the questions but also their confidence in the correctness of their

response. According to Echternacht (1972, p. 217): *“Advocates of confidence testing have stated that knowledge is neither a dichotomous nor a trichotomous affair, which traditional multiple choice tests seem to imply, but it is continuous in the sense that there are varying degrees of knowledge”*.

The addition of confidence levels to objective tests may help counter the concerns of Khan, Davies, & Gupta (2001) that *“misinformation is particularly dangerous because the student strongly believes that the wrong answer is correct”*. Constructing a marking scheme that accounts for both the respondents’ confidence and the correctness of their answer is likely to deter answer guessing; another common criticism of objective tests. Again, while the use of students’ confidence levels in their students’ responses could equally be used in computer or paper-based tests, the computer is likely to be more efficient in dealing with the more complex marking algorithm. The additional complexity arises since confidence based tests are typically graded on the students’ responses to the question as well as their stated confidence in their response. A student that selects the correct answer coupled to a high confidence rating is graded higher than a student that selects the correct response but offers less confidence in the correctness of their selection.

Assertion reasoning questions (ARQ) are presented as another variant of multiple-choice questions and seek to test the higher order cognition of the test participants. In ARQ assessments two questions are coupled to form a single entity. The role of the respondent is to judge the correctness of the *assertion* and also to justify the response by selecting an appropriate *reason*. According to Connely (2004, p. 362) *“its structure facilitates the construction of questions that test student learning beyond recall. In particular, higher level thinking and application of key concepts may sometimes be more easily constructed using this format, than by using a conventional multiple-choice approach alone”*. Connely also finds *“assertion reasoning test performance to be a good predictor of student performance in essay work”*. Issues associated with such tests are pointed out by Williams (2006, p. 293), when he writes *“it took some time for the students to become accustomed to the format”*. Indeed some of his students noted how the complexity of the language might have been a distraction and impacted on the difficulty of the tests. This leads Williams to note that *‘the findings of this paper do not contradict the conclusion drawn by Connely, [on ARQ and essay scores] but suggest that student performance in ARQ tests may have as much to do with their linguistic skills and the time taken to process complex prose as with their conceptual understanding and problem-solving ability’* (ibid p. 298). This problem is exacerbated for students with English as an alternative language.

Russell (2008) has shown how presenting individual questions that (unbeknown to the students) are related to one another might facilitate an insight into answer guessing and help establish the students' conceptual understanding of a topic area. This is done by post-processing the students' responses to the separate yet related questions. In Russell's example the available answer choices offer the students a chance to contradict themselves on their previous responses. It is the selection of contradictory answers that implies the students are guessing or have a lack of real and/or conceptual understanding of the topic area.

Irrespective of the innovations and adaptations of the objective test, criticisms remain. According to Hakel (1998, p. 4), "*constructing a response differs substantially from recognising one in a list of potential responses*". Dangel & Wang (2008) talk of a need to engage students in higher order thinking which presents a need to move away from selecting a correct response. Ryan & Greguras (1998, p. 183) note the "*movement in the educational arena toward replacing multiple-choice testing with performance assessments stems partly from a concern that typical tests are dissociated from the real-world skills supposedly assessed*". They go on to discuss their rationale for avoiding MCQ's, and argue that "*life is not multiple choice and students should not be assessed in a way that is incompatible with reality*".

Although there are issues that may stifle engagement with the use of online objective tests, it is appropriate to acknowledge the support they have offered for formative assessment. Objective tests do not have to be high stakes nor do they have to be thought of as the *only* assessment. They could be low or no stakes, be part of a range of formative assessment activities and hence form an important part of students' ongoing learning activities. Objective tests provide an opportunity for prompt feedback and can be tailored to suit the individual needs of the learner via adaptive tests, see for example (Bryan & Glasfurd-Brown, 2005; Lilley & Barker, 2007). They can also be accessed a number of times by the same student.

The use of technology to reduce the time to provide feedback in a first year computer science module is presented by Díez, Díaz, Aedo, & Fernández (2008). Their use of technology, which still involves staff input, helped reduce the time to return the marked work from three weeks to an average of five days. The authors go on to note that "*the sharp drop in correction times has had a direct effect on the course. The possibility of identifying generalized knowledge gaps among students in a short time span has enabled the adoption of corrective measures. For example, the recurrence of mistakes in the use of control*



*sentences led to the provision of additional reading material and supporting exercises” (ibid p. 5).*

Smaill (2005) describes his Online Assessment System with Integrated Study system (OAS/S). OAS/S is a web-based objective test system specifically developed to counter the large proportion of time teachers spent on assessments rather than on teaching. According to Smaill, for a class size of 550, 75% of the teachers' time is committed to assessment. This drops to 65% for a class size of 200. The functionality of OAS/S includes the use of random questions and the choice for teachers to offer the assessment in a *practice* or *test* mode. The major difference between the practice mode and test mode is the level of supervision required and the timing allowed for the students to participate in the assessment. A similar assessment system (*MarkIT*) is described by OConnell & OCinneide (2005). *MarkIT* also provides random questions and was developed to administer web based assessments to electrical engineering undergraduates. Both systems, *MarkIT* and OAS/S, will have no doubt brought the benefits of prompt feedback and reaped efficiency gains too. Smaill, for instance, suggests for a typical year-2 course of 200 students, the savings are about 50 hours. For a typical year-1 course of 550 students, the savings are about 180 hours. Following discussions with OAS/S users regarding the time it takes to create, administer and mark OAS/S and typical assessments it seems that a break-even point (time-wise) occurs when there are more than 66 students.

Although Smaill's work indicates the efficiency gains likely to arise with ICT based assessments and suggests that web-based assessment systems offer 'any time' study, the place of study is likely to be limited to where an internet connection is available. Many ICT-reliant assessments explicitly require the students to be stationed at a computer to both receive the assessment and also to submit their answers. Forcing students to engage with an assessment task while stationed at a computer might disadvantage some students. Ricketts & Wilks (2002, p. 477) noted, when they changed from paper based test to computer based tests, that "*a few students felt that online examinations were more stressful or had disadvantaged them because they hate computers*". They go on to say "*in the first year (2000) the most common negative remark from students (20 students out of 129) related to the difficulty of interacting with the assessment because of the way that it was presented on the computer screen*". When talking about self-efficacy and confidence in using the internet and computers, (Sam & Othman, 2005, p. 213) challenge the notion that "*the more [use of the internet and the computer] the better*". They suggest that "*undergraduates who used computers often may not necessarily feel more comfortable using them. Possibly, other factors such as the types of application used, the purpose for using, and the role of*

*satisfaction, could also influence computer self-efficacy and computer anxiety.*” Any potential for bias does not follow the principle of good practice in undergraduate education respecting diverse talents and ways of learning (Chickering & Gamson, 1987).

Even with the potential for bias, there are a wealth of applications and experiences of CAA activity in the literature. Conole & Warburton (2005) provide a comprehensive review of activities in the design, delivery and analysis of online assessment over the period 1995-2005. They suggest that “*many of the barriers and enablers to effective implementation mirror those found in the uptake and use of other learning technologies; however, CAA differs because it is perceived as more high risk and central to the learning and teaching process*” (ibid p. 27)

Explorations of the literature highlight the potential of computer assisted assessments to enhance the educational effectiveness of the assessment and/or the resource efficiency. Nicol & Milligan (2006), for example, reviewed numerous examples of CAA and showed how these met the previously described *Seven Principles of Good Feedback Practice*.

There are challenges remaining with computer based assessments, specifically related to access, the validity of tests *per se* and the additional stress, and subsequent downturn in student performance that any computer based activity may induce.

Having reviewed the relevant literature, the following sections introduce the context for the research situation.

## 2.2 The research situation: University, student group and host module

This research is located at the University of Hertfordshire and was undertaken in response to the student failure rate on the first year Fluid Mechanics and Thermodynamics module. The following provides a relevant introduction to the University, the student group and the host module.

### 2.2.1 The University

The University of Hertfordshire (UH) is a post-1992 university with an overall student population (in 2007-08) of 22,835 students (HESA, 2008). In 1997-98 the numbers of students studying at the University was 17,230. In both years the majority of students were

registered on undergraduate degree programmes (~83%). and most students engage in full time study (~75%). Both figures are higher than those of the sector average, see Table 1-1. The number of UK students at UH is lower than the sector average which suggests the inclusion of students from other European Union countries and beyond.

Programmes of study are taught by 23 Academic Schools (2006) which are clustered to form six Faculties. The School of Aerospace, Automotive and Design Engineering (AADE<sup>3</sup>) is one such School and is located in the Faculty of Engineering and Information Sciences. AADE offers undergraduate Degree programmes in the area of Aerospace, Automotive and Mechanical Engineering. These programmes are offered as a B.Eng stream with an entry tariff of 260 UCAS points<sup>4</sup> from three subjects. General Certificate in Education at Advanced Level ('A' Level) passes in Maths and Science, or equivalent, are prerequisite components of the entry tariff.

### 2.2.2 Study rates in AADE

All AADE's undergraduate programmes are valued at 360 credit points and are taught over three years to campus-based students. Placement opportunities are available to students after they have completed their second year of study. Each year of study comprises two semesters and each semester typically lasts 11 teaching weeks. The profiles of the various degree programmes are identical in that each year of study comprises modules totalling 120 credit points. Modules in AADE are either 15 or 30 credits. 15 credit point modules are taught over one semester and equate to around 150 hours of student effort. 30 credit point modules are taught over two semesters and equate to around 300 hours of student effort. The total student effort for each module is related to both teacher-student contact and non-contact time. Non-contact time includes the student input required to complete assessment activities and guided and independent study activity.

Distributing the total expected student effort across the number of teaching weeks (for all the modules taken in a semester) implies the students should be studying at a rate of 55 hours

---

<sup>3</sup> The School of Aerospace Automotive and Design Engineering evolved from the Department of Aeronautical, Civil and Mechanical Engineering mentioned in Chapter One.

<sup>4</sup> 260 UCAS points equates to a General Certificate in Education at Advanced Level ('A' Level) grade profile of B, C & C.

per week. The reality, however, is likely to be different given that the teaching weeks in both semesters are interspersed with non-teaching weeks. Although it is anticipated that students will study in both teaching and non teaching weeks the maximum number of available weeks in each semester is unlikely to exceed 16. This implies a more probable study rate of around 38 hours per week, hence the students should be spending around 14 hours per week on each module.

### 2.2.3 Fluid Mechanics and Thermodynamics: An overview

Each of AADE's undergraduate programmes set out to provide a foundation in core engineering subjects at year one which is replaced by increasing numbers of more programme specific modules at years two and three. Fluid Mechanics and Thermodynamics is one such core/foundation engineering module and, because of its relevance to all mechanical engineering disciplines, is undertaken by all first year AADE B.Eng students. Although the module comprises two subject areas, in AADE they are combined to form a single 15 credit point module. The rationalisation exercise leading to more common modules (discussed in Section 1.1.2) taught at level one with more programme specific modules at year two and three does not appear to be unique to UH. While arguing the need for an integrative engineering curriculum, Crawley *et al.* (2007) use an arched vault as a metaphor for the curricula, and show science located firmly as one of the foundations onto which disciplinary courses are constructed. A capstone course binds together the pillars representing the different components of the curricula.

During this research programme teaching arrangements within Fluid Mechanics and Thermodynamics were typified by a combination of formal lectures (1:>125), small group tutorial sessions (1:~20) and two practical laboratory sessions (1:~20). For the duration of the module each student would have been exposed to around 30 hours of formal lectures, 20 hours of informal tutorials and four hours of laboratory studies, The teaching arrangements suggest a total of 54 hours of contact time. Following the guidance for expected student study time (a 15 credit point module will demand around 150 hours of student effort), the remaining 96 hours of student effort is associated with the assessment and non-contact study activity. Within the module the lectures are typically didactic and can generally be viewed as information-giving episodes. The small group tutorials present more opportunities for active student engagement and are subsequently more dialogic. The laboratory studies provide the students with an opportunity to apply the theories presented in the lectures to practical, real world, situations.

In addition to the formalised contact sessions, the students' learning was supported by on-line resources and activities. These on-line activities were administered through the Managed Learning Environment.

### 2.2.3.1 The Definitive Module Document

The formal description of the module is provided in the DMD. The DMD describes, among other things, the module's aims, its intended Learning Outcomes, the methods of student engagement and the assessment arrangements. Information relevant to this research, drawn from the DMD, is presented below. The DMD is presented in Appendix A.

Analysis of the Aims, Learning Outcomes and the Module Content presented in the DMD indicates the foundational nature of the module. The DMD states *"This module introduces students to the fundamentals of fluid flow and thermodynamics and provides a basis for higher level modules in aerothermodynamics, vehicle aerodynamics and thermofluid mechanics"*.

A taxonomy for problem-solving related to engineering and related disciplines is offered by (Platts, Dean, Sears, & Venable, 1980). The list essentially describes a hierarchy that builds from; *application* of a routine with no requirement for its selection; *diagnosis*, namely selection and use of a correct routine; identifying *strategies* on the use of routines and their interaction with other routines; *interpretation* of a real world situation into a soluble form and *generation* of routines which are new to the user.

The description of Learning Outcomes (presented in Table 2-4) is aligned with the lower levels of the problem solving taxonomy and also the lower levels of Bloom's Taxonomy of Educational Objectives (Bloom, 1956); i.e. knowledge, comprehension and application; and hence reinforce the foundational nature of the module.

Table 2-4. Learning outcomes – Fluid Mechanics and Thermodynamics

<i>Learning Outcomes: Knowledge and Understanding</i>	<i>Learning Outcomes: Skills and Attributes</i>
Identify the properties of liquids and gases	Apply Fluid Mechanics principles to the analysis of fluid systems
Identify thermodynamic systems and processes	Analyse Fluid Mechanics problems using dimensional analysis
	Apply the first law of Thermodynamics to the analysis of open and closed systems
	Apply the perfect gas concept to simple gaseous systems

#### 2.2.4 Assessment arrangements

The summative assessment arrangements within the module in 2001-02, that is, prior to the introduction of the new assessment programme, comprised two laboratory studies and associated laboratory reports, an in-module phase test and a final examination. All the assessments were taken individually by the students and all assessments were marked by the teacher. The students' grade for the module was constructed from 70% of their examination score and 30% of their coursework score.

#### 2.2.5 The students

Good instructional design considers the needs of the students as well as that of external agencies (Biggs, 2003; Kemp, Morrison, & Ross, 1994). Biggs, in his 3P model, talks of the presage and the importance of drawing on what students bring to their studies, and Kemp *et al.* suggest the importance of identifying the learner and their characteristics in learning design. These might include personal characteristics; such as age, motivation, work habits, interests; social characteristics, attitudes, socio-economic level, cultural background and beliefs, language skills, sources of bias, and disabilities; such as vision or motor ability; which might impair learning.

Student numbers enrolled on the Fluid Mechanics and Thermodynamics module during this research programme were routinely in excess of 125. Details of the number of students exposed to the research programme are given in Table 2-5.

Table 2-5 Number of students exposed to the research programme

Year	2002-03	2003-04	2004-05	2005-06	2006-07 <sup>5</sup>
N	128	133	163	175	129

The majority of the students are 19-year-old males. The student population includes both home and international students.

With regard to external commitments 50 (39%) of the 2006-07 cohort indicated they were not working while studying and 48 (37%) were. The remaining 31 (24%) of the cohort did not respond to the question (see Table 2-6). 36 (~28%) of the cohort noted that, while studying, they undertook on average more than 10 hours paid or voluntary work per week. Further, using the middle of the hour ranges for the working students will show that the mean number of working hours was 14 and the mode 13. These figures are similar to those presented elsewhere (de la Harpe, Radloff, & Parker, 1997). In the de la Harpe study, which was also a second semester first year cohort, (n=111), 70% of the students were working, the mean number of working hours was 16 and the mode was 10.

Combining the expected study rate of 38 hours per week with the students' external commitments, which as indicated is in excess of ten hours per week for 28% of the cohort, suggests that these students were committed to around 50 hours per week. If the trend for more students to seek employment while studying continues then such student commitment is likely to be a common feature of HE.

A possible common feature of HE, working while studying is not without its problems. In a report of the first year HE experience in the UK, Yorke and Longden (2007) noted that students working more than 12 hours cited the demands of employment while studying as influences on their non-completion.

Table 2-6. Number of hours per week the students are engaged in paid or voluntary work (2006-07 cohort)

Hours	0	1-2	3-5	6-10	11-15	16-20	21-25	26-30	31-35	>35	No response	Total
n	50	1	6	5	22	6	2	5	1	0	31	129
%	38.8	0.8	4.7	3.9	17.1	4.7	1.6	3.9	0.8	0.0	24.0	100

<sup>5</sup> 2006-07 were not included in the main study. They were used to establish the number of hours students were engaged in work whilst studying.

### 2.2.6 The teaching team

The module is supported by a teaching team comprising four members of staff. All members of the teaching team are full time staff members of AADE. Each member of the teaching team was allocated their own responsibilities and had different interactions with the students and the module. The major interactions of the teaching team are shown in Table 2-7.

Table 2-7. Major interactions of the teaching team with the students and the module

	Team member			
	A*	B	C	D**
Student interactions	Through lectures and tutorials	Through lectures, tutorial and the MLE	Through the laboratory activity	Through the laboratory activity and the MLE
Assessment interactions	Set and mark the final examination	Set and mark the final examination	Set and mark the laboratory report	Set and mark the laboratory report

\* Team Member A is the module leader

\*\* Team Member D is the originator of this research programme and the author of this thesis.

## 2.3 Design considerations

Following the review of the literature and the local context, three design themes have been identified. The design themes arise due to their relevance to this research and in particular the ways in which they can act as design drivers for a new assessment programme. The assessment programme has an explicit intent to improve student learning and student performance in the Fluid Dynamics and Thermodynamics module. The themes identified to steer the development of the assessment programme<sup>6</sup> are:

- alignment
- having a learning focus
- resource efficiency

Underpinning the three themes are six principles. These are described below -

---

<sup>6</sup> This thesis uses the term 'programme' to represent the broader system of the assessment and the term 'program' to represent a computer program. The computer programs, shown in Chapter Three, are therefore components of the broader assessment programme.



### 2.3.1 Design theme 1. The assessment programme shall be aligned

*Principle 1:* The assessment programme shall connect the assessment tasks to the module learning outcomes

This principle is offered to align the students' interpretation of the curriculum to the actual curriculum. In adopting this principle the students' activity will also be appropriately oriented such that the issues associated with assessment backwash and the hidden curriculum are reduced.

*Principle 2:* The assessment programme will complement and support the existing appropriate teaching and learning settings

Supporting the first principle is the notion that the assessment programme is to be viewed as being complementary to, rather than competing against, any existing effective teaching and learning settings. The assessment programme should form an important part of the curriculum and the teaching and learning environment. This includes traditional face-to-face settings as well as online settings.

*Principle 3:* The assessment programme shall inform teachers of their students' progress

In addition to tasking the students, as is the convention with traditional assessments, the assessment programme will also construct meaningful information for the teachers.

The information flowing back to the teachers should be sufficiently fine-grained, regular and up-to-date in order to support teaching strategies oriented around notions of a teaching and learning dialogue. The students' conceptions, and misconceptions, will provide the intelligence on which teachers can make informed decisions on teaching adaptations.

### 2.3.2 Design theme 2: The assessment programme shall be learning focused

*Principle 4:* The assessment programme shall stimulate and focus the students' effort on activities that are likely to lead to learning.

The assessment programme will be consistent with the principles of assessment for learning. The assessment tasks will stimulate and explicitly require student activity, through opportunity to practise, which will be followed by prompt feedback. Further, to maximise the

learning potential of the assessment programme the students will be encouraged to share their current understandings and misconceptions. The assessment programme will seek to develop the students' understanding of the relevant topic areas and also actively encourage meaningful student study behaviours. This will include the purposive encouragement to spend time-on-task, ensuring the students' effort is distributed across the topic areas and also the creation of assessments that do not facilitate the sharing of answers. The assessment programme will articulate and reinforce appropriately high expectations of the students and develop appropriate studentship. Hence, the assessment programme will also seek to establish and promote positive consequences outside the students' immediate understanding of the topic areas.

*Principle 5:* The assessment programme will respect and support the individual student while also valuing the learning benefits to be realised from mutual peer-to-peer support.

Individual students have their own preferences in terms of where and when they study. They are also likely to be exposed to different and varied external demands. Further, some of the students are likely to be more comfortable around computers than others. This assessment programme will not seek to advantage or disadvantage individual students due to their personal preferences or their competing demands.

The learning environment will also support and challenge the individual student while also encouraging social interactions to support learning, i.e. a community centeredness.

### 2.3.3 Design theme 3. The assessment programme shall be resource efficient

*Principle 6:* The assessment programme will not be overly demanding on the available resources

Meaningful learning oriented assessment can be readily created if there exists a willingness and an abundance of available resource. The intention in setting out and developing this assessment programme is not to develop a set of principles or offer an assessment framework that is impracticable or unsustainable. The intention here is to adopt a more pragmatic perspective and create an approach to assessment that is both educationally effective, as implied by principles 1-6, whilst also being resource efficient.

Resource efficiency in this research, is considered as the broad intention that the assessment programme is seen as a viable proposition for use by colleagues in similar

contexts. The resource costs and time to run the assessment programme should be such that they are not overly bearing in the decision to adopt the assessment programme. Further, the assessment should not be prohibitively burdensome on the students and teachers in terms of their access to, and usability of, the technology developed to support the assessment.

## 2.4 Close of Chapter Two

Assessment is repeatedly seen as having a significant impact on students' activity as well as their perception of the curriculum. Following a review of the literature this chapter culminated in the production of three themes, underpinned by six principles. The themes and principles will guide the development of a new assessment programme. The themes will help to align the students' perception of the curriculum with that of the actual curriculum and will also stimulate learning.

The following chapter describes the developed assessment programme. It is argued here that the assessment programme is educationally effective and, because of the technologies developed, is resource efficient.

## 3 System development

This chapter describes the design and development of the assessment programme in response to the design themes identified in the preceding chapter. While features of the development are transportable and relevant to other modules, disciplinary areas and levels of study, the development was driven by the specifics relating to high numbers of students failing the first year module - Fluid Mechanics and Thermodynamics. The contribution this chapter makes, therefore, is presented as the design and development of an assessment programme to specifically support Fluid Mechanics and Thermodynamics.

To demonstrate the specifics of the assessment programme, this chapter includes descriptions and accompanying images of the developed technologies. The images have been included to demonstrate the typical functionality of the technology rather than present a comprehensive review of how they are used to support all aspects of the module. The examples shown relate to hydrostatics.

### 3.1 The WATS approach to assessment: An overview

In response to the identified themes set out in Chapter Two, the developed assessment programme centres on the use of student-unique, Weekly Assessed Tutorial Sheets (WATS). The WATS engage all students in out-of-class activity that is aligned with the current in-class lecture topic. In doing so the WATS stimulate practice opportunities that are regular and relevant to the ongoing teaching and learning interactions. The weekly tasks are consolidatory, typically requiring around 1-2 hours of student effort and, following the students' submissions, are feedback rich. What follows is a description of the main features of the assessment programme. Within the description is a justification for the assessment tasks being:

- weekly
- formally assessed
- based on tutorial sheets
- student unique and
- feedback rich.

Embedded within these justifications are the intended consequences arising from the designed functionality. Following the description and design justifications, the remainder of the chapter presents the technologies developed to operate the assessment programme.

The technologies include those required to create the weekly assessment tasks (the *WATS Set Up Wizard*), to collect the students' responses (the *WATS Data Gatherer*), and to mark and provide student feedback (the *WATS Marking Wizard*).

## 3.2 Responding to the design themes

The design themes set out in chapter two provided a focus for the development of the WATS approach to assessment. Features of the assessment programme relating to the design themes are presented in Sections 3.2.1 - 3.2.3.

### 3.2.1 Features of the WATS approach to assessment supporting design theme 1

Design theme 1 sets out that the assessment programme shall be aligned. Notions of alignment are articulated through three related principles:

- Principle 1: The assessment programme shall connect the assessment tasks to the module learning outcomes.
- Principle 2: The assessment programme will compliment and support the existing appropriate teaching and learning settings.
- Principle 3: The assessment programme shall inform teachers on their students' progress.

#### 3.2.1.1 The WATS are Tutorial Sheets

Aligned teaching seeks to join up the teaching, the module learning outcomes and assessment activity. The WATS support alignment by stimulating appropriate and relevant practice opportunity through a tutorial sheet<sup>7</sup>. The practice opportunity reaffirms the content of the preceding lecture and creates a consolidatory non-threatening task that is also aligned with the module learning outcomes. Although the tasks for a first year module in Fluid Mechanics and Thermodynamics are likely to comprise questions oriented around *application* and the associated lower levels of Bloom's taxonomy, engaging students in these tasks set down essential foundations on to which learning in higher levels of a cognitive domain can be built.

---

<sup>7</sup> A tutorial sheet is typically a collection of questions related to the content of the current topic being studied.

### 3.2.1.2 The WATS create feedback to teachers

The primary motivation for the weekly tasks is to stimulate regular student activity and student engagement with the curricula. Following the students' engagement with the WATS they receive feedback on their performance. By design the WATS programme also creates meaningful feedback to help the teachers see their students' performance. This information provides useful evidence with which the teachers are able to make purposeful and evidence-based teaching adaptations. This creates a cycle of out-of-class student activity shaping the in-class teaching activity.

### 3.2.2 Features of the WATS approach to assessment supporting design theme 2

Design theme 2 is at the core of the development of the assessment programme. Design theme 2 sets out that the assessment programme shall be learning oriented. Supporting design theme 2 are principles 4 & 5:

- Principle 4: The assessment programme shall stimulate and focus the students' effort on activities that are likely to lead to learning.
- Principle 5: The assessment programme will respect and support the individual student whilst also valuing the learning benefits to be realised from mutual peer-to-peer support.

Features of the assessment programme that respond to design theme 2 are set out below.

#### 3.2.2.1 The WATS are Weekly

Significant consequences arise from weekly tasks. First, by aligning the tasks with the current topic of the lecture, the weekly task provides an immediate opportunity to reinforce, out of class, the key messages of the lecture and supporting tutorial sessions. Second, weekly tasks are, by definition, regular and hence engage the students across all areas of the curriculum. In doing so the students' effort is aligned with *all* the module learning outcomes, a consequence of which is the ability to reaffirm, via the assessments, what constitutes the actual curriculum. Third, the regular nature of the assessment programme distributes the students' effort across the whole semester and subsequently develops a more appropriate study pattern. The students are continuously stimulated to think about and work on the module. The use of weekly tasks removes the potential for students to concentrate their efforts solely around the examination period. Weekly tasks, followed by prompt feedback, also provide the students with a chance to review their own learning as the weeks

progress. Finally, as noted in Section 3.2.1.2, the regular nature of the assessment provides immediate and up-to-date information for the teachers. This allows the teachers to see their students' on-going progress; the topic areas that the students appear to grasp and those that they appear to be struggling with. This feedback to the teachers is vital if teaching is to be viewed as a dialogic activity that is informed by student performance.

### 3.2.2.2 The WATS are student unique

The justification to develop an assessment programme that embeds student unique data in the tasks arises from the identified benefits to learning. These benefits are described below.

#### 3.2.2.2.1 Sharing answers has no relevance

The uniqueness of the students' numerical data dictates that each student's correct answer will also be unique to them. Having student unique answers immediately stops any student benefiting by sharing with, or receiving answers from, their peers. In doing so the assessment programme does not inadvertently support or encourage inappropriate student behaviours. Student unique tasks require individual student activity.

#### 3.2.2.2.2 Collaboration and student-to-student support is possible

Even though answer sharing has no relevance in this assessment programme it is still possible for the students to collaborate on the problem solving methodologies. Hence the benefits of peer supported learning are still available. There is, however, a continuum of potential peer collaboration. At one end of the continuum is a meaningless situation where a considered 'expert' in a peer support group takes control and does the task for other members of the peer group. At the other end of the continuum exists a more appropriate situation where all members of the peer group seek to help and learn from one another. A good peer support group will scaffold each student such that they are all suitably positioned to respond to their own individual tutorial sheet.

#### 3.2.2.2.3 Parity of assessment is assured.

While each student tackles their own unique tutorial sheet, the whole class tackles the same question(s). It is the data within the questions that brings the student uniqueness to the activity and not the body of the question. As discussed, using student-unique answers immediately eliminates the potential for answer sharing. This also deflects criticisms levelled at users of student unique assessments created by combining questions randomly selected

from question banks. Randomising questions from question banks also helps to avoid issues of answer sharing but problems arise because an assurance of the parity of questions, that is, a guarantee of their equal difficulty, is difficult to provide.

### 3.2.2.3 The WATS are formally Assessed

The significant intent of the WATS approach to assessment is to stimulate activities that lead to learning, but, as identified in chapter two, learning is only likely to occur if the students are active and, in this instance, engaged with the weekly tasks. Stimulating weekly student activity that leads to learning is a non-trivial task. To encourage student engagement, the students' responses to the tasks are formally assessed such that their weekly performance contributes to the students' grade in the module. Given the weighting of the final examination for this module (70%) and the fact that 11 WATS are used, each WATS only accounts for around 1.5% of the overall module grade. Hence the students' engagement is stimulated by a low-stakes assessment activity.

### 3.2.2.4 The WATS support any-time and any-place study

The WATS approach to assessment is an example of CAA and is highly dependant on ICT. In this CAA example, however, the assessment does not force the students to work at the computer nor does it require the student activity to be undertaken at a specified location. The only two constraints that exist are i) the need for students to submit their responses to the weekly task before midnight on the submission day, one week after the task has been set, and ii) the need for the students to submit their responses to a dedicated computer program. This computer program resides on University servers, access to which is available from either of the Learning Resource Centres. The major implications of these minimal constraints are that this assessment programme does not create any unintended bias that might exist by forcing students to work at a computer, as discussed in chapter two, nor does it disadvantage students with varied demands on their time. A part time student, a working student or a student with family commitments can decide, within that week, when they are best able to undertake the task.

### 3.2.2.5 The WATS programme is feedback rich

Student engagement in the weekly assessment activity is followed by prompt, individual and group feedback. Typically, the day following the submission deadline, the students receive a



personalised feedback e-mail. This feedback e-mail contains the student's response, the correct answer, the marks available and the marks awarded. Importantly the feedback e-mail also includes feedback statements based on intelligent diagnostics of the student's responses.

To complement the individual feedback, a full worked solution and a *WATS League Table*<sup>8</sup> is uploaded to the module area on the MLE. The immediacy of the feedback is important so that the students' recent action can be seen against the feedback they receive. Teachers also benefit by seeing immediately the student performance data on each week's assessment task.

### 3.2.3 Features of the WATS approach to assessment supporting design theme 3

Design theme 3 sets out a pragmatic view that the assessment programme shall be resource efficient. Supporting design theme 3 is principle 6:

- Principle 6: The assessment programme will not be overly demanding on the available resources.

#### 3.2.3.1 The WATS approach to assessment uses technology to support the assessment and feedback processes

The main response to the need for resourcefulness arises from the design intent to firmly embed the use of ICT into the assessment programme. The technologies are intended to facilitate the use of the assessment programme by removing much of the drudgery and resource intensive processes from the associated assessment and feedback activities. This is particularly important since, as identified in Sections 3.2.2.1 - 3.2.3.2, the assessment is weekly, student unique and feedback rich. These design elements create numerous processes that in a non-technological solution are likely to render the assessment programme too resource intensive and prohibit its deployment. Developing technology to support these design features operationalises the assessment programme and makes the design ideas a practical reality. The development and use of technology to support the assessment programme is discussed in Section 3.4.

---

<sup>8</sup> The *WATS League Table* is discussed fully in section 3.4.5

### 3.2.3.2 The WATS establish an additional connectivity to, and between, the students

*StudyNet* is used to provide a virtual base for the WATS programme. The students collect their weekly tasks from *StudyNet* and *StudyNet* is used to feedback the WATS worked solution and the *WATS League Table*. Drawing the students back to *StudyNet* on a regular basis creates an additional connectivity to the students; enabling them to be directed towards additional news items or supplementary teaching resources. Further, given that *StudyNet* is provisioned with a discussion forum, a virtual space exists where the students can seek, as well as offer, student-to-student support. The explicit use of the *StudyNet* to support the assessment programme extends the connectivity *between* students and hence supports principle 5. Additionally, and in relation to design theme 3, this feature provides an opportunity for the students to work together in ways that are not demanding of staff time, and facilitates another connection where the students are able to help each other and learn from additional student-to-student interactions.

Having outlined some of the main features of the WATS approach to assessment and also indicated some of their intended consequences, the following section describes the WATS approach to assessment in action. The workflow of the WATS approach to assessment is shown in Figure 3-1.

Figure 3-1 Workflow of the core functionality of the WATS approach to assessment

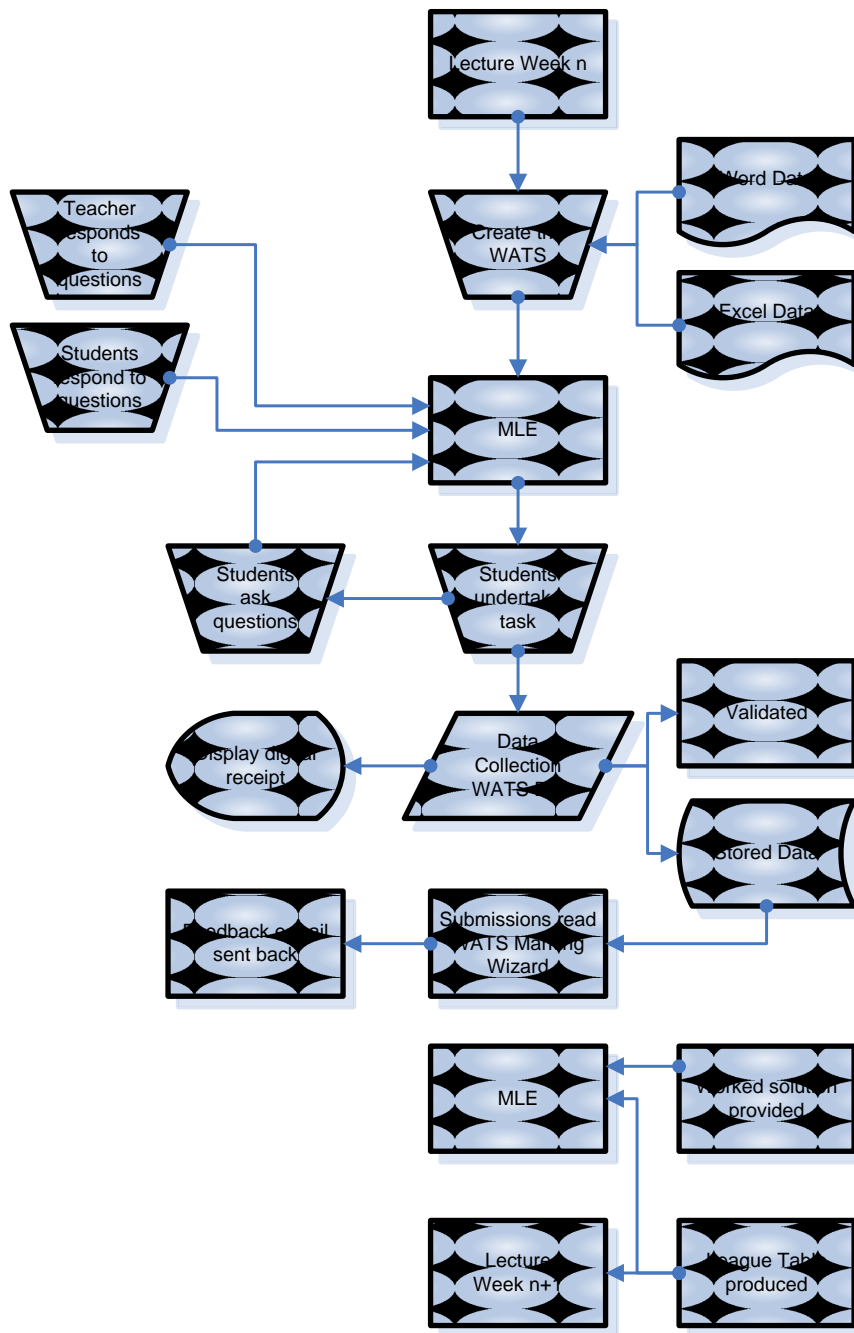

### 3.3 Student and teacher interactions with the assessment programme

Numerous interactions exist between the students, teachers and the developed technology (see Figure 3-1). While these interactions are interwoven and describe a complex interplay between the different parties, the following describes separately the typical activity of the

students and the teachers. A description of the developed technologies to support the programme concludes the chapter.

### 3.3.1 The students' engagement with the WATS approach to assessment

The following sections, 3.3.1.1 - 3.3.1.5, indicate the designed student engagement with the WATS approach to assessment.

#### 3.3.1.1 Sharing the motivation for the development

During the first lecture the students are introduced to the rationale for the development of the assessment programme. At this time they are presented with the intended benefits and what is expected from them. The assessment programme places continuing demand on the students and it is important that the students understand the demands and appreciate that they are the most significant beneficiaries of the assessment programme.

#### 3.3.1.2 Introducing the topic area of the WATS

During the weekly lectures (typically Wednesday mornings) the students are presented with material and concepts relating to specific areas of the curriculum. The lecture setting is used to provide background information, highlight an engineering application and show the importance of the current topic. The lecture also provides an opportunity for the students to engage with a tutor-led solution of a topic-related problem. The lecture is predominately a teacher-centric session.

Small group (1~30) tutorial sessions are run during the week of the lecture. The tutorial sessions allow the students to practise problem solving and consolidate their understanding of the concepts presented during the lecture. The problems and tutorial questions presented relate to the recent lecture topic and hence are also likely to be useful preparatory exercises for the current WATS. The tutorial setting creates a different type of student-teaching interaction from the lectures. The tutorials are more interactive and predominantly student-centric sessions.

#### 3.3.1.3 Student engagement with their WATS

The students are able to access their own WATS after the lecture. By design, the WATS are only made available to the students through *StudyNet*. During the week, and before the next

lecture, the students are required to have responded to their unique WATS and submitted their response to the *WATS Data Gatherer*. Within this week the students are able to discuss their work with their peers, seek help on the discussion forum and look back at the supporting lecture and tutorial activity. Within the weekly constraints the students are able to work on their task at a time and place that best suits them. Details of the *WATS Data Gatherer* are provided in Section 3.4.3.

#### 3.3.1.4 Student submission of their response

Having completed their WATS the students are required to submit their responses to the *WATS Data Gatherer*. The submission deadline is typically midnight on Tuesday. Setting a deadline at midnight the day before the next lecture ensures the weekly task is appropriately constrained between the topic introduction and the introduction of the next topic. The *WATS Data Gatherer* is password protected and guides the students through the submission process. At the end of the submission process the students are required to record the digital receipt issued by the *WATS Data Gatherer*.

#### 3.3.1.5 Feedback to students

During Wednesday morning, a week after the task has been set and typically a few hours after the students have submitted their responses, the students receive a personalised feedback e-mail. For each of the questions the feedback e-mail documents the students' answer, the correct answer (using the students' unique data), feedback on any errors and a closing statement encouraging the students to engage with the worked solution. In addition to the personalised feedback e-mails, a full worked solution is provided via *StudyNet*. The worked solution describes how the task is solved and where common mistakes are made. An updated *WATS League Table* is also provided via *StudyNet*.

### 3.3.2 The teachers' engagement with the WATS approach to assessment

Much of the teachers' interaction with the WATS approach to assessment has already been identified in Section 3.3.1. It is the teachers who explain to the students the motivation for the development of the assessment programme and its benefit to student learning (see Section 3.3.1.1). It is the teachers who provide the introduction to the topic area in the lectures and supporting tutorials (see Section 3.3.1.2). It is the teachers who make the WATS available to the students via *StudyNet* and it is the teachers who create the worked

solution and update the *WATS League Table* (see Section 3.3.1.5). The following Sections (3.3.2.1 – 3.3.2.6) describe other important teacher interactions in the operation of the WATS approach to assessment.

### 3.3.2.1 Creation of the WATS

The WATS comprise written questions into which student-unique Random Factors are embedded. This dictates the requirement of three separate functions, to create the WATS. First, the teachers need to write the body of the question. The body of the question should be aligned to the current topic area and support the relevant module learning outcomes. The body of the question should be written such that it has the feel of a traditional tutorial sheet. It should not be overly demanding nor should it be trivial. The body of the question should demand around one to two hours of student effort. Second, the teachers need to create the Random Factors. The Random Factors are typically numerical data sets and are created using the *WATS Set-Up Wizard* (see Section 3.4.2). Each student gets their own data set. Finally, the body of the question and the Random Factors are brought together using Mail Merge techniques to create the WATS. The WATS are subsequently loaded to *StudyNet* for the students to access.

### 3.3.2.2 Supporting the on-line dialogue

The assessment tasks stimulate student activity around which the students often ask questions. The students are advised to send all questions through to the discussion forum of *StudyNet* rather than send private e-mails to teachers. This helps develop a student-to-student support network since students are encouraged to help each other and offer advice relating to the questions being posed. Further, in steering the students' questions to the discussion forum in *StudyNet*, the teachers are not burdened with answering the same question more than once. This supports the design theme of the assessment programme being resource efficient. While there are clearly many benefits to be gained by steering questions via *StudyNet* and supporting student-to-student interactions, the teachers might need to respond to questions, provide clarification, or draw other students into the on-line dialogue.

### 3.3.2.3 Setting up the WATS Marking Wizard

At the time of creating the WATS, and before uploading the WATS to *StudyNet*, the teachers need to set up the *WATS Marking Wizard*. It is important to set up the *WATS Marking Wizard* before releasing the WATS to the students so that a check can be made for nonsensical answers arising from an unfortunate combination of Random Factors.

Setting up the *WATS Marking Wizard* involves creating the correct answers to each question using each student's unique data, setting the appropriate marking rules (marks and marking tolerances) and creating any question-specific feedback statements. Feedback rules are required to allow the *WATS Marking Wizard* to automatically select the appropriate feedback statement. A description of the *WATS Marking Wizard* is provided in Section 3.4.4.

### 3.3.2.4 Collecting, marking and providing feedback on the students' submissions

After the submission deadline has passed, the teacher retrieves the students' submissions file. The data in the students' submissions file is read into the *WATS Marking Wizard* by accessing the Visual Basic for Applications (VBA) code written directly into the *WATS Marking Wizard*.

After the students' submissions have been read into the *WATS Marking Wizard* it is then able to automatically compare the students' submitted answers with the correct student-unique answer. Hence, the students' answers are automatically marked using the marking rules, the students' answers, and the correct answers. The provision of the feedback e-mails is initiated by starting the appropriate VBA.

### 3.3.2.5 Uploading WATS League Table and Worked Solution

After the students' work has been marked, the teacher uploads an updated *WATS League Table* and *Worked Solution* to *StudyNet*. The *WATS League Table* allows students to see how they are 'performing' against their peers. The worked solution is intended to show students how the task should have been tackled and, along with the students' personalised feedback, is helpful for students to see where they may have made mistakes. Irrespective of the student's performance, the feedback e-mail always encourages them to look at the worked solution.

### 3.3.2.6 Linking performance with the lecture

Due to the timing of the submissions deadline (midnight on Tuesday) and the lectures (Wednesday mornings), the teachers are able to use the data found in the *WATS League Table* created automatically within the *WATS Marking Wizard* and use the data to shape part of the upcoming lecture experience. These evidenced-based adaptations provide additional feedback and can be used to revisit areas demonstrated by the students to be problematic, or to stretch the students where they have shown a good understanding of the topic area.

The preceding sections set out the designed student and teacher interactions with the assessment programme. It is apparent from the discussions that significant technological developments were needed to allow the assessment programme to function. The following sections take forward the need for technology and, more specifically, introduce the technologies developed to operate the WATS approach to assessment.

## 3.4 The need for technology

It is apparent from the preceding discussion that the assessment programme places significant demands on the teachers. Indeed, many of the tasks noted in Figure 3-1 and Sections 3.1 - 3.3 highlighted a significant demand to set, administer, collect, mark and provide feedback. While these demands exist for most assessment activity, the problems and demands are exacerbated here. With weekly assessments this process is repeated week-on-week. Further, since the weekly tasks are student-unique, the assessment programme introduces another layer of complexity. There is now a need to create Random Factors, embed them into questions to create student unique WATS and establish student unique solutions. These activities establish the student uniqueness of the assessment, which brings various benefits, but also increases the demands placed on teachers. Therefore, to allow the assessment to be practicable, many of the assessment activities are undertaken using ICT. The use of ICT thus supports the design theme of being resource efficient. The technologies specifically developed to support this assessment and their core functionalities are described in the following sections.



### 3.4.1 Creating the WATS

Each WATS contains a set of questions to form a weekly assessment task. They are created by combining a set of Random Factors into the body of the questions. To provide a context for a discussion on the questions and the Random Factors an example WATS is presented in Figure 3-2.

Figure 3-2 An example of a WATS. (Student unique data is highlighted)

## Fluid Mechanics and Thermodynamics

### Weekly Assessed Tutorial Sheet 7.

+

<b>Student Number</b>	1		
<b>Print your name</b>			
<b>Hand out date</b>	17 April 2008	<b>Hand in date</b>	23 April 2008

**Q1a).** A fluid of relative density 0.87 flows through a pipe of diameter 120 mm at 0.11 m/s. After passing through a gradual reducer the fluid leaves a 50 mm diameter pipe and discharges onto a stationary surface. Assuming that the surface slopes at an angle of 'A' degrees from the horizontal plane, as shown below, and that the surface somehow acts as a vane in that the fluid is deflected along its surface - calculate the forces **acting on the surface** for the angles shown in the answer boxes. You may assume that friction effects are negligible.

**Figure Q1a.** Definition of angle 'A' for the inclined surface.

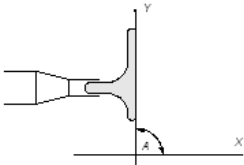
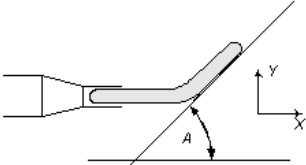
i) $A = 90^\circ$ (X force) (N) (1 Mark)	ii) $A = 10^\circ$ (net force) (N) (2 Mark)	iii) $A = 61^\circ$ (Net force) (N) (2 Mark)	iv) $A = 86^\circ$ (Net force) (N) (2 Mark)

**Q2.** 12.001 s flows through a contracting elbow which has an angle, 'A' of  $18^\circ$  i.e. as shown in figure Q2. Assume the inlet to the bend is 245 mm diameter and the outlet is 135 mm diameter and that the pipe lies in the horizontal plane. The static pressure at the pipe inlet is 4.80 Bar and the fluids specific gravity is 0.96. Calculate the net force and the direction of the force acting on the bend.

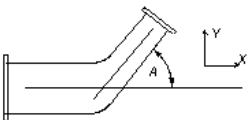

**Figure Q2.** Sketch of bend.

i) Net force (N)  (3 Mark)	ii) Direction of force. (As measured anti-clockwise from the top of the horizontal plane. i.e. AS SHOWN in all above examples.  (1 Mark)

**You must now enter your answers to the WATS Data Gatherer. You must do so by MIDNIGHT of the submission day. Due to the nature of this continuous assessment programme all late submissions will receive a zero score. Take care with the units! Details of the WATS data gather are provided on StudyNet**

The collection of the WATS used during 2003-04 is presented in appendix B.

### 3.4.1.1 The body of the question

The body of question is the text and any accompanying images that form the weekly assessment task. The body of the question is the same for each student and hence dictates that each student is presented with the same assessment task and level of cognitive challenge. In creating the body of the WATS the following information needs considering:

#### 3.4.1.1.1 The cognitive challenge and time demands of the WATS

The WATS typify a tutorial sheet and so the cognitive challenge they set and the time demands they place on the students should be reflected in the questions posed.

The WATS should provide an appropriate challenge and be neither too trivial nor overly complex. If the assessment task is too trivial then, in addition to potentially undermining the validity of the assessment, the task will not demand sufficient effort from the students. Students who do not value the assessment task are likely to adopt a surface approach to their studies. Further, if the assessment task is overly complex there exists a potential to undermine the students' confidence in the subject which is likely to stifle their inquisitiveness and willingness to further explore the subject domain. Hence, an overly complex or trivial assessment task is likely to reduce the learning potential of the task.

Related to the need for an appropriate challenge is the realisation that the assessment task will naturally require student time. The assessment tasks should encourage an appropriate amount of time-on-task. This will be dependant on the modular value and might also be cognisant of other on-going student activities and assessments. If the task demands too little of the students' time, it might be viewed as a trivial exercise, the consequences of which have already been discussed, whereas an assessment task that is too time-consuming is likely to have a detrimental impact on the students' other studies. Aligning the WATS with the notion of a tutorial sheet and the modular and assessment weighting of the Fluid Mechanics and Thermodynamics module suggests each week's task should demand around one to two hours of student effort.

#### 3.4.1.1.2 Alignment of the WATS with ongoing activity

In addition to aligning the assessment task with the module learning outcomes, the continuous nature of this assessment programme suggests the content of the WATS should also be aligned with the current or upcoming topic area. This helps align the students' understanding of what constitutes the actual curriculum. Further, setting the right cognitive

challenge and demanding an appropriate study time also helps align the students' understanding of what is expected of them.

#### 3.4.1.1.3 The WATS should require multiple responses from the students

The assessment task should be written such that multiple responses are required from the students. Ideally, each week's assessment task should be constructed from a series of questions or question parts. It is the students' responses that are marked and hence these create the opportunity on which to provide feedback. The assessment tasks, and the requirements for the student data that is gathered, should be written to gain an insight into the students' knowledge and their approach to problem solving. The feedback to the student, and also to the teacher, will be richer if there exists an opportunity to see the students' workings and their conceptions as they move towards completing the task. Multiple responses help provide such an insight.

Having created an appropriate question that takes account of the points noted above, there is now a need to create the Random Factors.

#### 3.4.2 The *WATS Set-Up Wizard*: Creating The Random Factors

The *WATS Set-Up Wizard* is a Microsoft Excel workbook with additional functionality programmed via VBA. The role of the *WATS Set Up Wizard* is to create the Random Factors. The coding of the routines to create the Random Factors are hidden from the users but are accessed via standard software interface controls – i.e. buttons and entry boxes.

The Random Factors are data pieces embedded into the WATS. Although they close the question, that is by adding the data to the body of the question, their sole purpose is to create the student uniqueness in the WATS. In the majority of instances the Random Factors are numerical.

### 3.4.2.1 Controlling the Random Factors

To create each Random Factor, in addition to providing a unique name, information on a set of controlling conditions is required. The controlling conditions for each Random Factor are the:

- *lowest permissible value* the Random Factor can be assigned;
- *highest permissible value* the Random Factor can be assigned;
- *level of precision* that the Random Factor should be calculated to;
- *incremental value* that the Random Factor can be calculated from.

Constraining the Random Factors to have meaningful values, managed by the controlling conditions, enables each student to be presented with sensible questions. In doing so the students' calculated results are also likely to hold sensible and meaningful values. A consequence of seeing an appropriately posed question, which leads to the calculation of a meaningful answer, is the development of the students' 'engineering nous'.

### 3.4.2.2 Creating the Random Factors

Creating the Random Factors is a guided process from within the *WATS Set-Up Wizard*. Constructing *the WATS Set-Up Wizard* to facilitate the rapid production of the Random Factors aligns this task, setting up of the Random Factors, with the theme of being resourceful. Indeed *the WATS Set Up Wizard* was developed with the specific intention to efficiently create the Random Factors and guide users through the creation process without requiring them to understand the intricacies of the underlying functionality.

The workflow and functionality of the *WATS Set-Up Wizard* to create the Random Factors, is given in Figure 3-3. A description of the workflow set out in Figure 3-3 is presented in Table 3-1. An image of the actual *WATS Set-Up Wizard* is shown in Figure 3-4.

Figure 3-3 Workflow of the WATS Set-Up Wizard

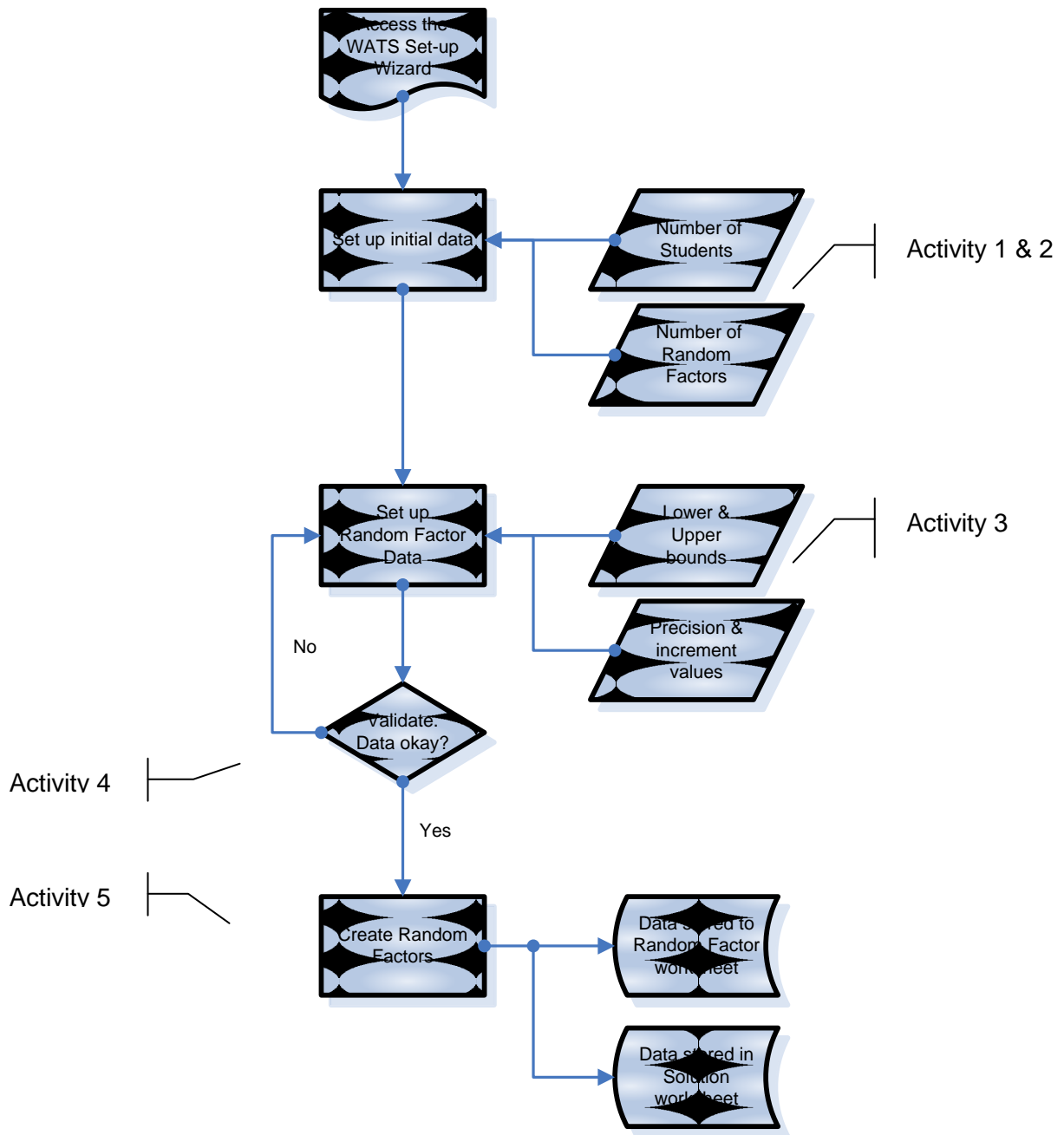

Table 3-1 Description of the separate entities identified in the *WATS Set-Up Wizard* workflow diagram (Figure 3-3)

Activity no	Description	Action	Notes
1	Set up the number of Random Factors and the number of students	Enter the values	Using the <i>WATS Set-Up Wizard</i> , enter the number of Random Factors and the number of students.
2	Create empty Random Factors	Button click	Clicking the button ( <i>set up random data</i> ) starts the Visual Basic for Applications routine to places blank controlling conditions for each of the Random Factors (uses information set in activity 1).
3	Complete the controlling conditions for each of the Random Factors	Enter the values	For each of the Random Factors, enter the name, lowest permissible value, highest permissible value, precision and step value.
4	Validate the controlling conditions	Button click	Click the <i>validate data button</i> – the VBA routines check for known input errors in the controlling conditions (as set in activity 3).
5	Create the Random Factors	Button click	Clicking the button ( <i>create Random Factors</i> ) starts the Visual Basic for Applications routine to create the Random Factors. These are created according to the controlling conditions entered at activity 3. The quantity of each random factor created is controlled by the number of students entered at activity 1. Random Factors are created on a separate <i>random factor worksheet</i> and also copied to a <i>solution worksheet</i> within the same workbook.

Figure 3-4 Screen shot of the WATS Set-Up Wizard

**WATS\_Setup Wizard** (version 1.1) Date of issue: 25 Aug 2005

**No of Random data items**  1

**No of students**

**Details for Random Factor # 1**

Random Factor Name	Q1 height a
Lowest value in Random Factor range	0.1
Highest value in Random Factor range	0.4
Precision of values for Random Factor # 1	2
Value of increment/step in range	0.01

2a

**Details for Random Factor # 2**

Random Factor Name	Q1 height b
Lowest value in Random Factor range	400
Highest value in Random Factor range	1000
Precision of values for Random Factor # 2	0
Value of increment/step in range	1

2b

**Details for Random Factor # 3**

Random Factor Name	Q1 rho
Lowest value in Random Factor range	800
Highest value in Random Factor range	950
Precision of values for Random Factor # 3	0
Value of increment/step in range	1

2c

Buttons: Set Up Random Data, Refresh!, Validate Data input, Make Random Factors, Save File, Clear ALL Factor Details, All Data - set the same

Adjustment buttons: Lowest Value - set the same (1), Highest Value set the same (10), Precision - set the same (2), Increment - set the same (0.1)

3, 4, 4, 4, 4

A description of the labelled items in Figure 3-4 is given in Table 3-2.

Table 3-2 Description of the highlighted areas of the *WATS Set-Up Wizard*

Item	Description
1	Entry of initial conditions. Number of Random Factors and number of students.
2	Controlling conditions for the individual Random Factors.
3	For ease of use, all VBA routines are initialised by 'button-clicks'.
4	If required, a common set of controlling conditions can be applied to all the Random Factors.

Examples of the Random Factors created with the controlling conditions shown in Figure 3-3 are given in Figure 3-5.

Figure 3-5 Example Random Factors for the controlling conditions set in Figure 3-4.

Student Number	Q1 height a	Q1 height b	Q1 rho
1	0.26	522	849
2	0.19	619	902
3	0.33	607	858
4	0.33	655	931
5	0.31	430	860
6	0.22	524	882
7	0.34	960	818
8	0.39	904	801
9	0.12	883	938
10	0.21	555	834
11	0.33	817	828
12	0.28	603	854
13	0.19	466	947
14	0.29	574	879
15	0.18	735	935
16	0.35	577	919

The preceding discussions described the WATS approach to assessment, identified some of its perceived benefits and introduced the *WATS Set-Up Wizard*. As noted in Section 3.3.2.3 creating the WATS is typically followed by a need to establish the student unique correct solutions. This is done via the use of the *WATS Marking Wizard*. Before introducing the *WATS Marking Wizard*, the data collection facility, the *WATS Data Gatherer*, is described.



### 3.4.3 Data collection: The *WATS Data Gatherer*

Before the submission deadline the students are required to submit their responses to the weekly tasks. The students' responses are made to the *WATS Data Gatherer*. The *WATS Data Gatherer* is a bespoke computer program specifically written to support the assessment programme and manages the entire submission process. The functionality provided by the *WATS Data Gatherer* is shown in Figure 3-6.

Figure 3-6 Functionality and workflow of the *WATS Data Gatherer*

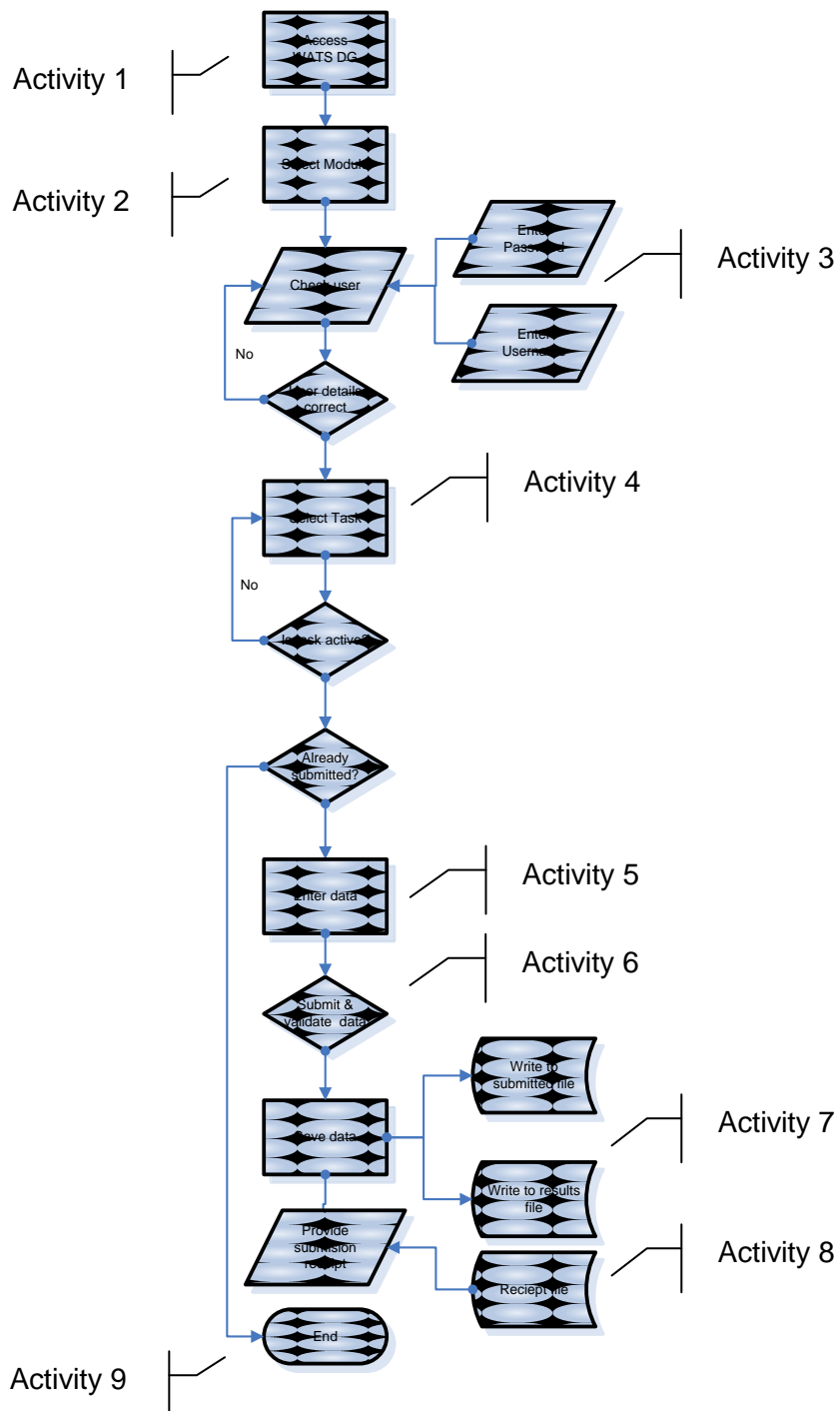

A description of the individual entities identified in the *WATS Data Gatherer* workflow diagram, Figure 3-6, is given in Table 3-3.

Table 3-3 Description of the main entities identified in the *WATS Data Gatherer* workflow diagram (Figure 3-6)

Activity no	Description	Notes
1	Start program	The program, the <i>WATS Data Gatherer</i> , is located on the Universities main server, access to which is obtained from either of the Universities two Learning Resource Centres
2	Students select the module to which they wish to respond	The WATS approach to assessment is being used in numerous modules across the University.
3	Student enter their password and student number	The students will have been sent this data from via the <i>Distribute WATS Passwords Wizard</i> . The <i>WATS Data Gatherer</i> validates the user by referring password data files. Separate password data files exist for each of the modules using the program. After positive verification the students are presented with the <i>WATS Selector</i> dialog box.
4	Students select the weekly task to which they wish to respond	The <i>WATS Data Gatherer</i> identifies the current status of the WATS tasks and takes appropriate action. For instance, access to the entry screen for the different weekly tasks are made inactive if they have, i) finished, ii) are not yet ready for student response or, iii) have already been responded to by the students. This status information is gathered from additional 'module and WATS specific' data files.
5	Students enter their responses	Having accessed an active WATS task the students and then able to enter their responses to that task.
6	Students submit their entered responses	After entering their responses the students now submit their responses by clicking the 'submit' button. At this stage the <i>WATS Data Gatherer</i> validates the entered data. The program will flag an error and require student action if non-numeric responses are submitted to areas where the program expects numeric responses. Further, the program will raise a warning if the students do not submit a complete set of answers to a weekly task. In this case the program will identify to the students the unanswered questions, but ask if the students wish to continue.
7	WATS Data Gatherer writes to files	The <i>WATS Data Gatherer</i> now writes the students' submissions to data files. The students' submissions are written to the <i>results file</i> . A separate file that shows the student engagement in the WATS tasks is also written to; this is the <i>student submitted file</i> . The <i>results file</i> is used by the <i>WATS Marking Wizard</i> (described later). The <i>student submitted file</i> is used by the <i>WATS Data Gatherer</i> to de-activate that WATS task for that student. (See activity 4)
8	Students collect digital receipt	Upon successful submission the <i>WATS Data Gatherer</i> writes to the screen a digital receipt. The digital receipt is unique for each student and for each WATS.
9	The program closes	

The *WATS Data Gatherer* is programmed to take submissions to various modules and different weekly tasks within each of the various modules. Access to the program is password protected. Hence, upon successful access the *WATS Data Gatherer* is able to steer the 'known' user to the correct submission area. In addition to collecting the students' responses, the *WATS Data Gatherer* writes to separate data files to enable the program to communicate more fully with its users. This additional communication includes information relating to the status of the various weekly tasks; e.g., if the student is able to submit data, if the program is not yet ready to take responses, or if the student has already submitted and so cannot submit again.

In addition to collecting numeric data, which is the typical data collected by the *WATS Data Gatherer*, the assessment programme was developed further to take other data types and hence provide additional ways of engaging the students.

#### 3.4.3.1 Addition of free-text

The initial WATS, as well the majority of the current WATS assessment activity, focuses on the use of numerical responses. The motivation for collecting numeric responses has already been discussed, but essentially arises due to the need to provide opportunities to practise solving engineering problems and also to facilitate an assessment programme that can readily exploit automated computer marking capabilities. To help develop the students' cognition and also gain an insight into their interpretations of the practise opportunity the *WATS Data Gatherer* has been developed to take and store free-text responses.

Although the free-text responses are not marked by the technology, the *WATS Data Gatherer* writes the students' responses to a file in such a way so as to facilitate ease of reading and, if required, ease of manual marking. In terms of the information in Table 3-3, the students' free-text responses are written to a separate file along with the other actions at activity 4. The use of free-text input opens up the opportunity to present the students with different questions and also explore their ability to operate at different levels of a cognitive hierarchy. The free-text questions offer a complimentary function to the calculations in that they allow for the teachers to ask their students to articulate their understanding rather than prove it via calculations.

Example questions requiring a free-text response include:

- In your own words describe Bernoulli's Equation
- Often in manometry we ignore the density of one of the fluids – why is this?
- What useful data can you assume when dealing with flows from large tanks?
- In your own words describe the purpose of Dimensional Analysis and explain how engineers might benefit from using the technique.

Inviting students to respond '*in their own words*' was a purposeful decision to gain the students' thoughts rather than encourage a response copied from the internet. Not only does the free-text provide new ways to question and interact with the students but it also opens up new opportunities to gain feedback from them. Examples here include-

- What one thing / topic would you like more help on?
- What one or two things could we do to help you better understand the subject?

Students' responses to such questions provide valuable information to teachers wishing to respond to the students' identified need. This, again, supports a more student-centred learning environment.

Seeing students as a valuable resource is part of a teaching philosophy that acknowledges students as contributors to, as well as consuming, resources for learning. The free-text data collection facility of *WATS Data Gatherer* was used to support this philosophy. Examples here included asking students to each provide:

- one hint or tip on the subject that might be useful to another student;
- one multiple-choice question together with five possible answers (indicating the correct response).

Hence, in addition to the thinking and, therefore, learning that arises from the student's individual engagement with the previous examples, the output from such inclusions into the *WATS Data Gatherer* was a collection of resources generated by the students to aid their cohort's learning.

The majority of the WATS activity is oriented around calculation and problem solving. Inclusion of the free-text allows different aspects of the students' understanding to be made visible. The free-text stimulates the students' thinking and subsequent learning beyond calculations. The addition of the free-text data collection, and the consequent

questions students can be asked, is aligned with the design driver set out in chapter two, that *the assessment programme is learning focused* and in particular it supports the underpinning principle (*principle 4*) that *the assessment programme shall stimulate and focus the students' effort on activities that are likely to lead to learning*. Good learning is not constrained to one level of a cognitive taxonomy or hierarchy. Good learning operates at various levels of the taxonomy and the free-text facility challenges students to operate at different levels.

#### 3.4.3.2 Using the WATS Data Gatherer to gain feedback from the students

In addition to including free-text to help the students' learning, the *WATS Data Gatherer* was programmed to gain the student view on the WATS approach to assessment. The student view was collected by their response to closed questions via radio buttons describing their view on a rating scale and via free-text responses to open questions.

An example of a data collection screen of the *WATS Data Gatherer* is shown in Figure 3-7.

Figure 3-7. Example data entry screen

### 3.4.3.3 Validating and storing the students' submissions

After the student has entered their response, the *WATS Data Gatherer* validates the submitted data. The validation routine either:

- accepts the student's data as submitted;
- raises a warning which the student *may* wish to respond to (i.e. unanswered questions) or,
- raises an error which the student needs to correct before they are allowed to continue.

The data validation routine checks the correctness of the data-types and also the completion of all the required responses. It does not check the correctness of the student's responses.

At the end of a successful submission the *WATS Data Gatherer* writes the student's response to the *student result* files and also adds their student number to a *student*

*submitted file*. A file identification protocol exists to ensure the data is written to a file that relates to the chosen module and the chosen WATS task.

Having written to external files, and before automatically closing down, *the WATS Data Gatherer* finally distributes back to the screen a seven digit character string. This forms a digital receipt of the student's submission.

#### 3.4.4 Marking and the provision of feedback

Having collected the *results file*, written by the *WATS Data Gatherer*, the next phase of the assessment process involves marking and providing student feedback. This is undertaken using the *WATS Marking Wizard*. The *WATS Marking Wizard* is a Microsoft Excel workbook specifically developed to support this assessment programme. Enhancements to the normal functionality of a Microsoft Excel workbook have been undertaken by the development and inclusion of Visual Basic for Application (VBA) routines.

For consistency with previous discussions, the following presents the typical workflow and functionality of the *WATS Marking Wizard*, see Figure 3-8. This is followed by a description of the individual entities of the workflow diagram, see Table 3-3. The development section concludes with images of the *WATS Marking Wizard*.

Although interrelated, the main processes associated with the *WATS Marking Wizard* can be separated into three main areas. These are:

- setting up the student unique solutions, associated marking and intelligent diagnostics,
- reading the students' submission data, and
- providing the student feedback.

These activities are shown in Figure 3-8.



Figure 3-8. Workflow of the WATS Marking Wizard

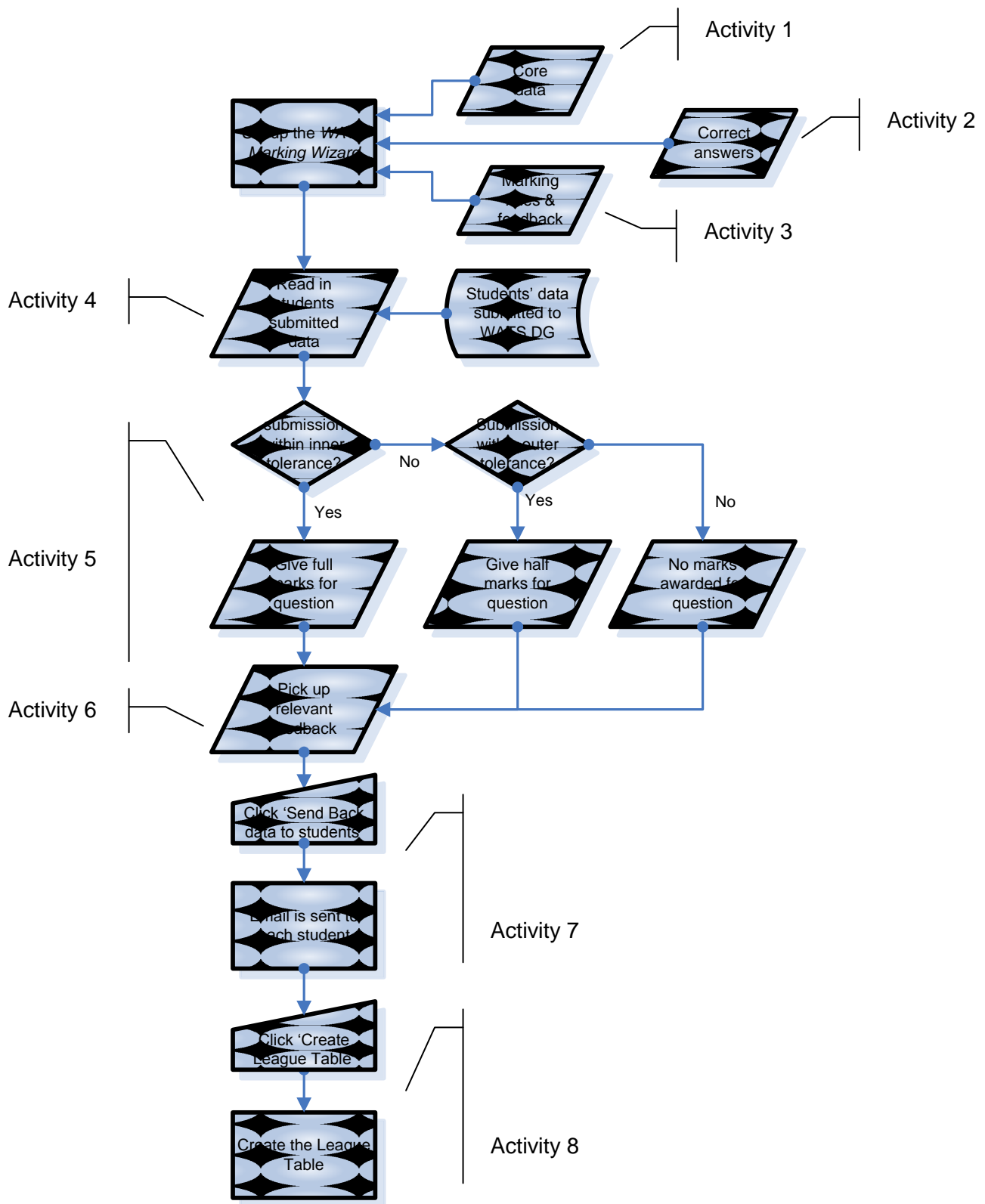

Table 3-4 Description of the main entities identified in the *WATS Marking Wizard* workflow diagram (Figure 3-8)

Activity no	Description	Notes
Setting up the marking activity		
1	Set up the core information	This includes; the teacher's name, the names and e-mail addresses of the students, the name of the module and the generic text to be used on the feedback e-mail.
2	Set up the Student unique answers	Using the student unique Random Factors solve, within the <i>WATS Marking Wizard</i> , the solutions for one student. Copy and drag the solution methodology to create unique solutions for all students. Check that all of the students' answers are meaningful.
3	Set up the marking rules & feedback statements	Create the grading structure for each of the answers. This includes i) the marks available for the correct response and ii) the marking tolerances. Where possible create tests to look for common issues with the students' responses. Create the feedback that is coupled to the outcomes of these tests. This activity might also be undertaken after the students' submissions have been read. That is you can create tests to generate feedback for already identified issues.
Read the students responses		
4	Read the students submissions	Clicking the <i>read students' submission</i> button initialises the routine to read the student <i>results file</i> . The <i>read students' data</i> routine is programmed to place the students' data in the correct place in the <i>Marking Wizard</i> .
Mark and provide the feedback		
5	Mark the students submissions	Since the marking is undertaken by the <i>Marking Wizard</i> spreadsheet, the marking process is initialised as soon as the students' submissions are read into the <i>Marking Wizard</i> . The marking rules immediately make a comparison between the correct responses (created in activity 2) with the students' submissions (activity 4). The marking rules determine if full marks, half marks or no marks should be awarded. Prior to releasing the feedback it is customary to check the students' results. For example, given the nature of the tasks, closed with known answers, it is likely that a few students will score 100%. Further, to help this checking process the <i>Marking Wizard</i> tallies and graphs the number of students scoring full marks for each of the question parts. A WATS task with no students scoring 100% or a question part with a relatively low proportion of students scoring full marks might indicate an issue with the marking rules.
6	Collect feedback statements	The <i>Marking Wizard</i> is programmed to collect student unique feedback. The feedback is collected from a statement bank that is unique for each weekly task. Feedback statements are collected if certain conditions are met.
7	Send back the feedback	Clicking the button ' <i>send data back to students</i> ' starts the process of provisioning the student unique feedback. Prior to sending out the feedback the <i>Marking Wizard</i> checks to see that the user has entered a password in to the correct cell. This is simply a pausing mechanism to stop sending out feedback e-mails by pressing the <i>send feedback</i> button accidentally. After checking the password, the <i>WATS Marking Wizard</i> establishes a personalised e-mail using the student's name, the question number and the text of the question, set in activity 1. The send back feedback e-mails routine then gathers the students' responses (activity 5), the correct answers (activity 2), a grade and also any diagnostic feedback statements.
8	Create the league table	Clicking the <i>create league table</i> button transfers the students' grades to the <i>League Table</i> . The students' scores are pasted alongside their names and the <i>League Table</i> is re-ordered according to any changes in position.

The following images show the main features of the *WATS Marking Wizard*. The *WATS Marking Wizard* is colour-coded to demarcate the different regions of the workbook. Within each colour-coded section, the darker coloured cells represent areas where users (teachers) are required or able to enter their own data.

Activity 1, entering the core data, is supported by the region of the *WATS Marking Wizard* shown in Figure 3-9. Two types of e-mails are produced by the *WATS Marking Wizard*, one type for students who submitted a response to the weekly task and another for students who did not. Within the *WATS Marking Wizard* the teachers are able to customise the title of the e-mail, the starting body of the e-mails and add their own e-mail signature. Towards the bottom of Figure 3-9 is the student information; this includes the student number, (generated specifically to support the WATS process), the student's name and their e-mail address collected from *StudyNet*.

Figure 3-9 Entry area for the core information

<b>Fluid Mechanics and Thermodynamics</b>				
<b>Weekly Assessed Tutorial Sheets</b>				
WATS Number	<input type="text" value="1"/>	MBR Password	<input type="text"/>	
No of Questions	<input type="text" value="8"/>			
<b>Submitted Subject Text (e-mail title)</b>		<input type="button" value="Send marked sheet back to students"/> <input type="button" value="Copy general data to all sheets"/> <input type="button" value="Copy results to League Table"/>		
<i>Results for F&amp;T WATS</i>				
<input type="text"/>				
<b>Non - Submitted Subject Text (e-mail title)</b>				
<i>Non - submission of F&amp;T WATS</i>				
<b>Submitted statement (e-mail body)</b>				
<i>Thank-you for submitting a sheet for WATS</i>				
<i>Details of your submission and your marks follow below ...</i>				
<b>Non - Submitted statement (e-mail body)</b>				
<i>It has come to my attention that you have not submitted a sheet for WATS</i>				
<i>They all count towards your coursework grade and are used to help you in your study</i>				
<i>Please ensure that you submit future sheets.</i>				
<b>Lecturers Name</b>				
<i>Mark Russell.</i>				
<i>Principal Lecturer.</i>				
<i>School of Aerospace, Automotive and Design Engineering.</i>				
<i>University of Hertfordshire.</i>				
<b>Student no</b>	<b>Family Name</b>	<b>First Name</b>	<b>e-mail address</b>	<b>Submitted? 1 (Yes) - 0 (No)</b>

Figure 3-10 identifies the area of the *WATS Marking Wizard* that deals with the students' submissions. The location and name of the file that stores the students' responses to the weekly tasks (as submitted to the *WATS Data Gatherer*) is shown at the top of the image (activity 5). Clicking the button, *Get Student Data*, activates the routine to read the students' responses, located in the file identified above, and subsequently places the students' responses in the correct place, concluding activity 6.

Figure 3-10. Student submissions

<i>Date</i>	<i>Time</i>	1	2	3	4
		<i>Q1 i)</i> <i>Force on Door</i> <i>(N)</i>	<i>Q1 ii)</i> <i>Line of Action</i> <i>(m)</i>	<i>Q2 i)</i> <i>Force on door</i> <i>(N)</i>	<i>Q2 ii)</i> <i>Line of Action</i> <i>(m)</i>
27/02/2006	12:22:21	194.98	5.77	33.92	1.87
27/02/2006	18:13:01	87.31	4.36	34.81	2.13
27/02/2006	16:25:06	423.05	7.15	288.90	5.39
27/02/2006	18:50:06	252.83	7.08	31.82	1.80

Figure 3-11 shows the area of the marking wizard that stores the teacher's calculated correct answers for each of the registered students (activity 2). These are either copied from the *WATS Set-Up Wizard*, or programmed as functions if the *correct* answers use some of the students' previous responses to arrive at an answer. At the top of this area of the *WATS Marking Wizard* is a control condition that describes the level of precision to which the feedback e-mail reports the correct answer.

Figure 3-11. The correct answers

1	2	3	4
<i>Q1 i)</i> <i>Force on Door</i> <i>(N)</i>	<i>Q1 ii)</i> <i>Line of Action</i> <i>(m)</i>	<i>Q2 i)</i> <i>Force on door</i> <i>(N)</i>	<i>Q2 ii)</i> <i>Line of Action</i> <i>(m)</i>
196.81	5.77	33.92	1.8667
87.31	4.36	34.81	2.1333
423.05	7.15	133.65	3.5333
252.83	7.07	31.82	1.8000
376.86	7.37	61.03	2.4000
216.75	5.76	82.91	3.2667

Having collected the students' responses and the correct responses, the *WATS Marking Wizard* is now able to undertake a numerical comparison. The control of the comparison, which leads to a numerical grade for each submitted answer, is undertaken by the area of the *WATS Marking Wizard* shown in Figure 3-12. The marking rules allow full marks to be

awarded if the students' responses are the same as the correct answer or within an inner tolerance. Half the available marks are awarded if a student's response falls beyond the inner tolerance but lies within the outer tolerance. The marks available, and the inner and outer tolerances, are configurable for each question. To help the efficiency of the system, generic marks and tolerances can be set and applied to all the answers. These are copied to the correct area of the *WATS Marking Wizard* after clicking the *Set Same Tolerance* and/or *Set Same Marks* button. This corresponds to activity 3 in Table 3-4.

Figure 3-12 Marking rules

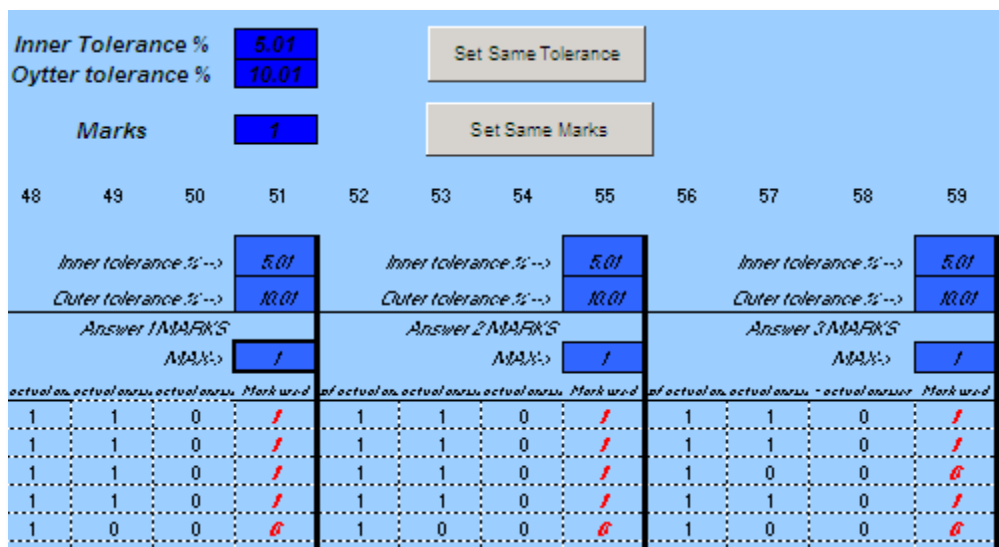

The *WATS Marking Wizard* tallies the marks awarded for each question and constructs a final grade (see Figure 3-13). Comparing the student's final mark with the maximum available mark allows the total grade to be presented as a percentage. Using additional rules an overall feedback type indicator is selected. The feedback type indicator is used in the feedback e-mail to offer a final thought on the student's performance. The text for the closing feedback statements for each of the four feedback types, together with the controlling conditions for automatically selecting the feedback type, are configurable by the user (teacher), as shown in Figure 3-14.

Figure 3-13. Final grades and feedback type

Overall score		
128	129	130
Max Available 12	Total Marks for this WATS %	Overall Feedback type
Total Marks for this WATS		
4	33	4
10	83	1
4	33	4
5	42	3
0	0	4
7	58	2
0	0	4
11	92	1
12	100	1
12	100	1
10	83	1
10	83	1
8	67	2
10	83	1
1	8	4
0	0	4

Figure 3-14. Controlling the feedback type and examples of closing feedback statements

Closing feedback details	Closing Response
Type 1 > <input type="text" value="50"/>	Well done. For this sheet your performance is first class.
Type 2 >	Your mark for this sheet is fairly good but does include some mistakes. Please take the time to look at the worked solution to see where you went wrong.
Type 3 < <input type="text" value="55"/>	Your mark for this sheet is above a pass but not exceptional. Please take the time to look at the worked solution to see where you went wrong.
Type 4 < <input type="text" value="35"/>	Your mark for this sheet is below a fail grade. Please take the time to look at the worked solution to see where you went wrong.

The feedback e-mail shows the student's submissions, the correct answer, the marks available and the marks awarded. An example of a feedback e-mail is shown in Figure 3-17. In addition to this data, the *WATS Marking Wizard* also facilitates the use of intelligent diagnostics; that is; the spreadsheet can be used to test for specific answers and hence diagnose common mistakes. Sample test calculations are shown in Figure 3-15. As with the closing feedback statements, these question-specific diagnostic tests are subsequently coupled to question-specific feedback statements (see Figure 3-16). The motivation for including this functionality in the *WATS Marking Wizard* is to help provide the students with feedback that is relevant and pertinent to them and their own demonstrable understanding of the weekly tasks.

Figure 3-15. Question specific diagnostic tests

141		142		143		144		145		146	
Calc	6	Calc	7	Calc	8	Calc	8	Calc	8	Calc	8
	3		3		2		2		2		2
	1		1		2		2		2		2
	3		3		2		2		2		2
	2		2		2		2		2		2
	3		3		3		3		3		3
	2		2		2		2		2		2
	3		3		3		3		3		3
	1		1		1		1		1		1
	1		1		1		1		1		1
	1		1		1		1		1		1
	2		1		2		2		2		2
	1		1		1		1		1		1
	1		1		3		3		3		3
	1		1		3		3		3		3

Figure 3-16. Question specific feedback statements

178		179	
7		8	
Well done - you seem to have calculated the correct pressure gradient	Well done - you seem to have calculated the correct pressure difference		
Whilst your pressure gradient has a negative number (which it should be), your value is not what I was expecting	Whilst your pressure difference has a negative number, which it should be, your value is not what I was expecting		
You seem to have a positive value of pressure gradient. For this calculation it should have been negative	You seem to have a positive value of pressure difference. Note for this calculation it should have been negative. The question asked for P <sub>Top</sub> -P <sub>Bot</sub>		

At the end of the above process, which can essentially be described as collecting the students' responses and marking the responses by comparing them with the correct answers, there is a need to provide the feedback to the students (activity 8 of Table 3-4).

Figure 3-17 shows a 'part' example of an e-mail to a student who responded to a weekly task, whereas Figure 3-18 shows an example of an e-mail sent to a student who did not submit a response to the weekly task. The motivation to send an e-mail to students not

submitting a response to the weekly task was to remind them of the importance of engaging in the tasks and also to alert them that their teacher has observed their non-engagement.

Figure 3-17. Part example of feedback e-mail

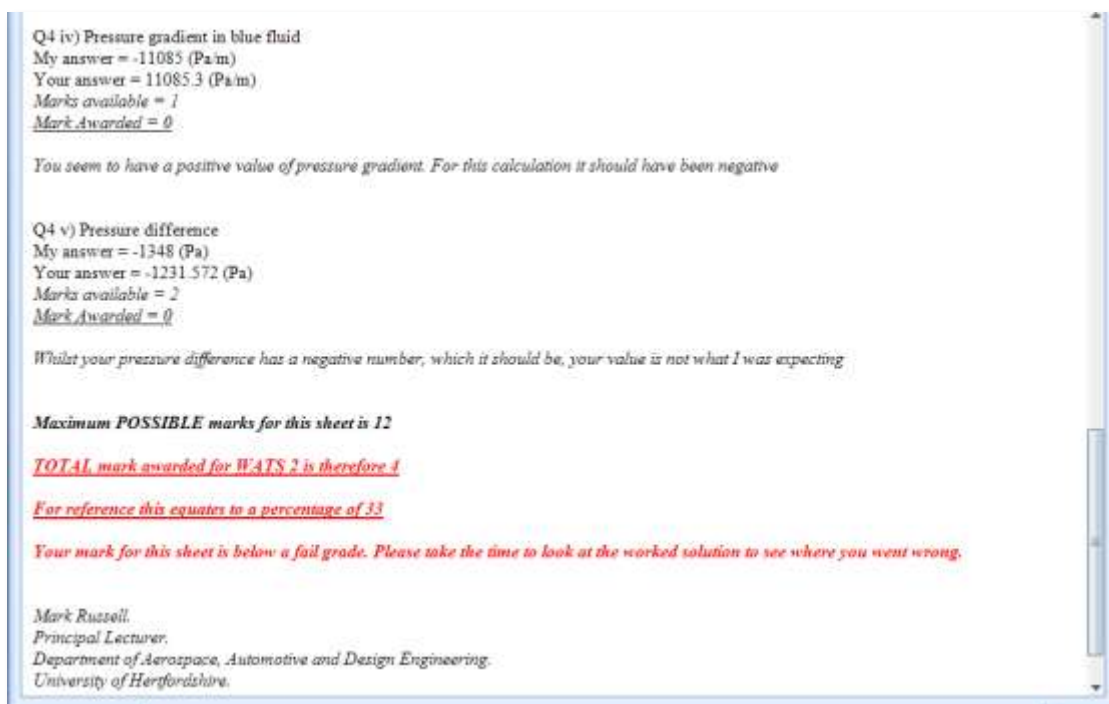
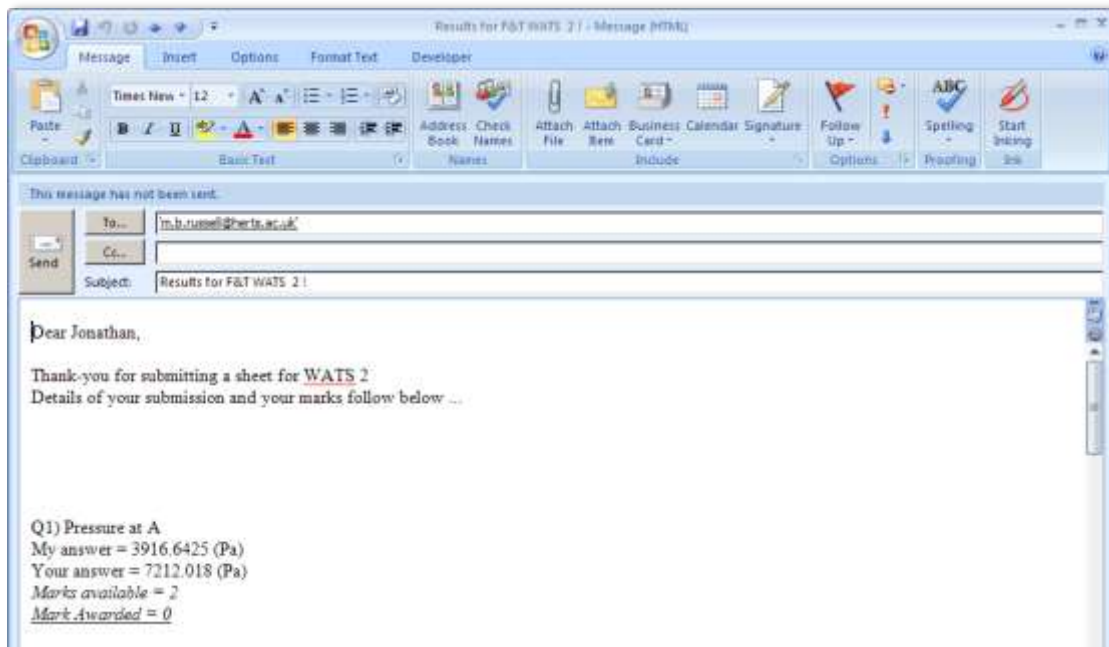
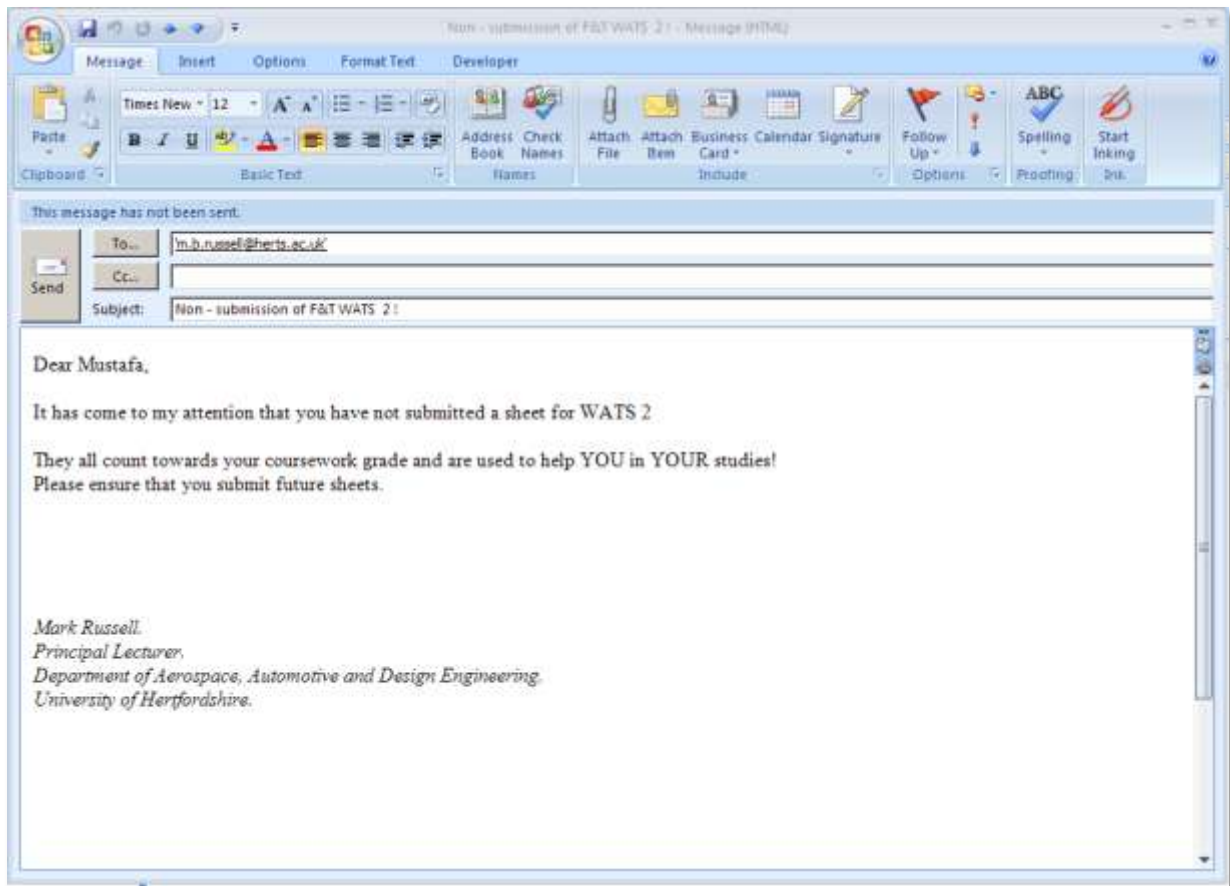



Figure 3-18. Example e-mail distributed to a non submitting student



The feedback e-mail reports the student's given response, the correct response based on the student's own individual data and the score awarded for that question part. This functional information is enhanced by the intelligent diagnostics written into the *WATS Marking Wizard*. For any incorrect answers the marking wizard seeks to stimulate additional student thinking rather than set out to offer a conclusive diagnostic of the mistake. This feature encourages additional engagement with the task, and is also fed back in the feedback e-mail. In some sense this encourages the students to use the feedback they receive. Although separate entities, the worked solution and the feedback e-mail are considered complementary to each other. It is the feedback e-mail and the embedded intelligence that motivates the students to review the worked example and re-engage in the task. Examples of worked solutions are presented in Appendix C.

### 3.4.5 The WATS League Table

The weekly nature of the WATS approach to assessment suggests that the students' weekly performance data can readily form a student-by-student performance profile; i.e. a *WATS League Table*. The *WATS League Table* can then be used to highlight students who are struggling with the topic, as well as to indicate students who are not engaging with the weekly tasks. Further, the *WATS League Table* can also be used to highlight any topic areas that are causing difficulty for the whole class. The *WATS League Table* is created automatically, within the *WATS Marking Wizard*, by the inclusion of appropriate VBA routines. A fragment of the *WATS League Table* is shown in Figure 3-19.

Figure 3-19 A fragment of a *WATS League Table*

ID	WATS number											Av	Last weeks Rank	This weeks Rank	Change in Position
	1	2	3	4	5	6	7	8	9	10	11				
JPH	100	100	100	62	100	83	100	57	27	77	100	82	22	18	up 4 place(s)
AUT	78	100	100	100	100	50	90	86	1	100	100	82	23	19	up 4 place(s)
GUM	78	100	100	100	83	83	100	93	0	65	100	82	24	20	up 4 place(s)
CMR	78	86	100	100	100	88	60	86	45	58	100	82	25	21	up 4 place(s)
ESH	100	86	86	100	100	67	93	64	1	100	100	82	26	22	up 4 place(s)
LEB	67	100	100	62	83	92	63	100	64	81	83	81	19	23	down 4 place(s)
COL	89	71	86	88	100	75	97	86	100	31	67	81	17	24	down 7 place(s)
GLF	100	100	100	62	100	100	73	93	0	62	100	81	27	25	up 2 place(s)
JAM	78	100	100	62	58	92	63	0	14	77	0	59	76	93	down 17 place(s)
BILZ	67	100	86	1	83	58	33	86	14	15	100	58	105	94	up 11 place(s)
LIE	67	100	29	62	17	33	87	57	73	15	100	58	106	95	up 11 place(s)
MUS	78	100	86	0	83	100	47	67	0	85	0	58	78	96	down 18 place(s)
ITA	78	93	71	46	100	58	60	29	0	31	67	58	97	97	up 0 place(s)
AND	33	100	100	54	67	75	23	86	41	38	0	56	82	98	down 16 place(s)
BH	100	100	29	62	100	92	47	86	0	0	0	56	83	99	down 16 place(s)
CHL	67	86	71	62	67	0	13	0	1	62	0	58	119	124	down 5 place(s)
GRL	44	100	29	77	17	67	17	67	5	15	0	58	120	125	down 5 place(s)
DJI	0	100	86	77	50	0	57	67	0	0	0	58	121	126	down 5 place(s)
BRA	0	100	0	46	0	83	60	29	0	0	100	58	133	127	up 6 place(s)
LAO	44	86	57	62	50	33	0	0	59	1	0	58	124	128	down 4 place(s)
BOL	44	57	0	100	100	50	7	1	1	31	0	58	125	129	down 4 place(s)
MDV	61	100	29	46	100	38	0	0	1	15	0	58	126	130	down 4 place(s)
N(s)	133	133	131	128	134	134	128	127	109	119	109				
Mean(s)	76	92	77	72	75	72	71	63	36	61	85				
Median(s)	78	100	86	73	83	75	80	64	27	62	100				
SD(s)	19	15	30	25	28	24	27	32	32	30	23				
D100(s)	0.76	0.35	0.54	0.67	0.58	0.84	0.85	0.83	0.96	0.81	0.35				
D75(s)	0.34	0.14	0.36	0.52	0.38	0.49	0.45	0.54	0.83	0.57	0.33				
D50(s)	0.25	0.06	0.25	0.46	0.28	0.34	0.36	0.51	0.82	0.55	0.11				
D50(s)	0.14	0.02	0.21	0.23	0.14	0.17	0.22	0.30	0.70	0.34	0.09				
N(e)	133	133	133	133	133	133	133	133	133	133	133				
D100(e)	0.77	0.38	0.57	0.72	0.59	0.83	0.86	0.83	0.98	0.83	0.50				
D75(e)	0.38	0.19	0.41	0.60	0.41	0.42	0.50	0.56	0.86	0.62	0.48				
D50(e)	0.29	0.12	0.31	0.55	0.32	0.36	0.42	0.54	0.86	0.61	0.31				
D50(e)	0.20	0.09	0.27	0.34	0.18	0.21	0.29	0.36	0.77	0.41	0.29				
r(e)	0.36	0.19	0.48	0.03	0.35	0.52	0.38	0.48	0.09	0.52	0.39	0.59			

Note:

- Column 1 is the student unique identifier (this is a three letter country code)
- Columns 2-12 are the students' performance on WATS 1-11 respectively
- Column 13 is the students' average overall WATS score
- Column 14 is the students' position in the league table last week.
- Column 15 is the students' position in the league table this week.
- Column 16 is the students' movement in the league table

### 3.5 Close of Chapter Three

Drawing on the literature review and the demands of the module as set out in the Definitive Module Document, this chapter proposed a new assessment programme; the WATS approach to assessment. The WATS approach to assessment uses student-unique weekly assessed tasks to create out-of-class activity that is aligned with the current in-class activity and module learning outcomes. The students' performance in the out-of-class activity flows to the teachers such that they are able to adapt the teaching and learning interactions to make them relevant to both the curriculum and the demonstrable needs of the students.

The chapter described the students' and teacher's interactions with the assessment programme. While those interactions are possible for small numbers of students, the number of students registered on the module dictates the WATS approach to assessment is not possible without recourse to use of ICT. In the WATS approach to assessment ICT applications have been designed, developed and implemented to help set the students work, distribute the work to the students, collect the students' submissions and mark and provide student feedback. This chapter introduced and described the technologies used to support the assessment programme.

The following chapter describes the methodological approach used to collect and analyse data arising from the implementation of the assessment programme.

## 4 Evaluation

Chapter Three described the development of the student unique, regular assessment programme. The WATS approach to assessment was established in response to the observed lack of student engagement and poor examination performance in a core first year engineering module; Fluid Mechanics and Thermodynamics. Analysis of the literature, the student group and the host module provided the pedagogical foundations and the design drivers for the assessment programme.

Having constructed the assessment programme, the next phase of the research moves to implementing and subsequently evaluating its impact. This chapter presents the research methods used to collect and evaluate the results. Aligned with the research questions, the impact of the assessment programme is evaluated against:

- Student support
- Student study behaviours
- Teaching and the provision of learning oriented support
- Student performance
- The students' perspective.

### 4.1 Research paradigms

A research paradigm shapes what we research, the ways in which we approach the research, the data collected and subsequently the ways in which the results of the research are presented. A research paradigm defines a philosophical framework.

Two research paradigms appear to dominate educational research; positivism and interpretivism.

Positivist research regards the world as being made up of observable, measurable facts. The reality of the findings are offered as being 'out-there' and independent from the researcher (Blaxter, Hughes, & Tight, 2006; Creswell, 1994). Research undertaken from a positivist perspective is presented as being objective and value free. The independence of the researcher from the research findings, and the suggested objective nature of the research, implies that there is no bias in the research. The results of positivist research are presented, therefore, as scientifically correct and reproducible.

Interpretivist research, on the other hand, is undertaken from a perspective where the researcher is knowingly connected to the research and the findings. The connection of the researcher and the findings suggests that the findings should be viewed as being value-laden and subjective. Hence, rather than finding an objective truth, interpretivists suggest that the reality is constructed by the individuals involved in the research situation (Creswell, 1994). Given the relationship between the interpretivist research and the researcher there is an implicit potential for research bias since the research methods, the observations and the interpretations of the findings are wedded to the researcher and the values and beliefs they bring to the research. Further, while discussing practitioner-research (case studies and action research) and the relationship of oneself within the research situation, Jarvis (1999) suggests that no meaningful research about practice can ever be presented in a value-free manner. To help put the findings of interpretivist research in context, the potential for bias should be acknowledged and made explicit by offering biographical details and statements about the researcher's underlying values and beliefs (Greenback, 2003).

#### 4.1.1 Research bias

In addition to the differences in the data collected and the methods used to analyse the data (quantitative data and statistical analysis of quantitative data is generally associated with positivist research whereas qualitative data is generally associated with interpretivist research (Leedy & Ormrod, 2005)) there appears a potential difference in the role of the researcher in the alternative research paradigms. Positivists claim the research is independent from the researcher whereas interpretivists suggest the researcher is intimately connected to the research and the subsequent findings.

The influences and interpretations of the observer might be obvious or inadvertent. For instance, Laurillard (2002) writes about determining engineering students' understanding of mechanical science by inviting them to draw the forces imposed on a given system. The explicit use of sketches to elicit the students' understanding has probably inadvertently biased the observation since the use of drawings is something experts relate to; novices tend not to use such techniques (Bransford et al., 2000). Clearly, known or not, the research methods, methods of data collection and the subsequent findings may be a function of the researcher and are not as remote from the researcher as proponents of the positivist paradigm suggests. Greenbank (2003, p. 793), writing about interpretivist research, argues that "*interpretivists accept the influence of their values, rather than falsely assuming they are able to depersonalise their research*". He goes on to present a collection of examples where

bias is introduced into the research findings from political, social and personal values and beliefs held by the researcher.

#### 4.1.2 Mixed-mode research: An alternative paradigm

Historically positivism and interpretivism were typically viewed as being competing research paradigms. More recently, however, an alternative perspective is appearing. While accepting that the different paradigms use different methods and have different affinities with different data types, some writers are suggesting the competing distinction is not helpful. Baur & Gaskell (2000) talk of an unproductive dispute over the different research values and methods, and Jones (2004) argues that the division between quantitative and qualitative research has become overdrawn and rooted in an excessively theoretical approach to social research. Both Baur & Gaskell's and Jones' suggestions support the rise of an alternative research approach; an approach that values both positivist and interpretivist research. The hybrid paradigm is referred to as mixed-methods or mixed-mode research paradigm.

Mixed-methods research purposely draws on both positivist and interpretivist research methods. In mixed-methods research the alternative research paradigms are seen as complementary rather than competing approaches. This suggests that both qualitative and quantitative data have a rightful place in the research and the research findings.

## 4.2 Influences on the choice of a research paradigm

Good research demands purposive justifications. This is true also in deciding which research paradigm to operate within. The research paradigm should be selected if its assumptions meet those of the phenomenon being investigated (Guba, 1981). The importance of the research situation and the data required to respond to the research questions are noted as being important factors in deciding on a research paradigm and use of associated research methods (Clark, 1999; Dick, 2003). A criteria-set for selecting a research paradigm is offered by Creswell (1994). The criteria relate to the researcher, i.e. their worldview, training, experience and attributes, the nature of the problem and the audience for the study. The values of the researcher, particularly those relating to competency in choosing a research paradigm, are offered by Greenbank (2003). The guidance is not limited to a choice between interpretivist or positivist research. Miller and Crabtree (2000) cited in Alltree (2008) argue for the legitimacy of combining methods if the research question justifies it.

The influences on the research paradigm and the methods used during this research programme are presented in Sections 4.2.1 – 4.2.4.

#### 4.2.1 The nature of the research questions

Following the design and development of a new assessment programme, the research questions set out to explore:

- i) the impact of the assessment programme on student support;
- ii) the impact of the assessment programme on the student study behaviours;
- iii) the impact of the assessment programme on teaching and the provision of learning oriented support;
- iv) the impact of the assessment programme on student performance;
- v) the students' perception of the usefulness of this approach to assessment.

The students' study behaviours can be explored via observation of their engagement in the assessment tasks. For example, the time and date of submission and their regularity of submission will start to provide an insight into the students' study behaviours. Observations of the students' discussions on *StudyNet* will also highlight how the assessment programme impacted on their study behaviours. Hence, both qualitative and quantitative data can be used to evaluate the impact of the assessment programme on student study behaviours.

Analysis of the students' marks in the assessment programme and the module final examination provide an opportunity to measure the impact of the assessment programme on student performance. The final examination score of the module presents an opportunity to explore if the WATS approach to assessment led to improvements in examination performance. Correlating the assessment and examination scores will indicate the strength of any relationship between the WATS and examination scores. The examination and WATS marks are numeric and are therefore amenable to quantitative analysis. The students' perceptions of the usefulness of the assessment programme can be explored via discussion and their responses to open and closed questions.

#### 4.2.2 The nature of the discipline and potential audience for the study

This research, and the development of the WATS programme, was initiated to combat the poor examination performance in an engineering module. By definition the academic School offering the module is likely to be more receptive to evaluations using a familiar research methodology, i.e. one that is used in their own subject related research. Typically the so-

called normal research (Kuhn, 1962) in engineering and science centres on the use of quantitative methods, and is undertaken within a positivist paradigm (Guba & Lincoln, 2000; Waller, 2006).

#### 4.2.3 The researcher's background

The disciplinary background of the researcher (and author of this thesis) is located in the area of Fluid Mechanics and Thermodynamics. The author has published various journal articles relating to Computational Fluid Dynamics (CFD) and the thermal performance of monolithic building components; see for example Russell & Probert (2004), Russell, Surendran & Probert (2002), Russell & Surendran (2000), Russell & Surendran (2001). This disciplinary-based research was undertaken from a positivist standpoint. The data was entirely numeric, the analysis was quantitative and the researcher typically considered himself as being remote from the data and the research findings. During the research activity, reported in this thesis, the benefits of qualitative data have been highlighted to the author. The potential influences of the researcher on the research have also been noted.

#### 4.2.4 The nature of the research approach

This research is consistent with the design features of case study research. Case study research typically begins with the researcher's interest in a particular set of phenomena (Blichfeldt & Andersen, 2006). Understanding the reasons that led to the high failure rate noted in Chapter One and developing an alternative, more learning oriented, assessment experience was the primary stimulus for this research project. Consistent with the collection of functions of case studies presented in Jarvis (1999), the research undertaken sought to illuminate the phenomena under study, chronicle the steps taken during the research and experiment/test the development.

While case study research shares many similarities with action research (Blichfeldt & Andersen, 2006), case study research is less collaborative with its participants (the students) in the ongoing research. The primary audience for the findings of case study research are the researcher's peers rather than the students. Engaging peers as the target audience for the research findings served two useful functions. First, the results, conclusions and findings were open to scrutiny and alternative perspectives from peers working in similar contexts. During the research programme I have sought numerous opportunities to engage peers and have benefited from the many questions asked. Second, keeping the students at a distance reduces the potential for the Hawthorne Effect to influence the findings. The Hawthorne



Effect is the name given to a situation where the subject's knowledge that they are in an experiment modifies their behaviour from what it would have been without this knowledge (Adair, 1984). Good research reduces the potential for bias. This research aimed to minimise bias and gain views from the students on their experience, not views that were skewed because a) they were key informants in the research design or b) they believed they were either privileged or disadvantaged in some way due to the deployment of a new assessment programme.

The implementation of the new assessment programme was phased over three years. The phasing was designed to minimise risk to the students and also facilitate the development of iterative enhancements.

Year 1 - Proof of concept

Year 2 - Developing and deploying ICT to take the concept forward

Year 3 & 4 - Ongoing enhancements

Although the three years can be compartmentalised as having different strategic aims, in every year there was a consistent desire to improve and enhance the assessment programme. The enhancements and modifications were based on evidence gained during each of the years.

#### 4.2.5 Adopting a mixed-method approach: A justification

The nature of the discipline, which includes the audience for the study and the associated prevalence of numeric data, suggests the adoption of a positivist research framework. This view, however, is countered by the nature of the research questions and the research approach (case study research). Hence, to respond to all the research questions implies a need to draw on both numeric and non-numeric data. For instance, while conversations with students (qualitative data), may bring out suggestions as to why the assessment programme may have impacted positively on their examination scores, it is more likely that an analysis of the examination scores (quantitative data) will demonstrate whether the assessment programme actually impacted on their examination performance. Further, collecting data relating to the timing of the students' submissions (quantitative data) will not provide sufficient insights into the students' study patterns and behaviours. Observations and discussions with the students (qualitative data) will provide useful information relating to the students' study patterns and behaviours prior to the students submitting their work.

As noted in Section 4.1.2, a mixed-method paradigm draws on both quantitative and qualitative data and associated methods. Here, they are viewed as being complementary rather than competing paradigms. Both paradigms provide opportunities to gain valuable and different insights into the impact of the work. Importantly, a mixed-method paradigm does not advocate the collection of different data for its own sake but rather collects different data to provide opportunities to gain different insights.

Using a mixed-method approach immediately provides opportunities to test the findings using triangulation. Triangulation takes various guises in research. *Methods triangulation* is the combination of methodologies in the study of the same phenomenon (Jick, 1979). The use of different data is made more explicit in Leedy & Ormrod's (2005, p. 99) definition of (methods) triangulation. They define triangulation as "*a situation where both quantitative and qualitative data are collected to (help) answer a single research question*". Methods triangulation, therefore, uses alternative methods to collect more and different forms of data. In doing so the conclusions are less likely to be inadvertently skewed by data types or the chosen method of analysis. Methods triangulation explicitly promotes the use of different methods and hence supports the mixed-method approach. *Data triangulation* (Denzin, 1970) is an approach that uses different data arising from the same method to look for agreement or otherwise with the findings. In the case of this research, data arising from the different cohorts exposed to the WATS programme constitute different data sets and hence facilitate data triangulation. Data triangulation tests the findings outside the immediate cohort, or year group, and helps ensure that conclusions are not drawn from an analysis of an atypical cohort. Testing across the cohorts again enhances the reliability of generalisations drawn from the findings.

Testing the findings using triangulation is repeated as a benefit by Clark (1999, p. 88) when he writes that "*one of the main advantages to be gained from triangulation as part of multi-method research design is that it allows the researcher to have greater confidence in the research findings than is the case when a single method is used.*"

### 4.3 Quantitative methods

Quantitative methods focus on numerical data and data that can be measured. In this research, both descriptive and inferential statistics are used.

Descriptive statistics provide descriptions of the data. The descriptions include the students' performance within the WATS assessments and the examination. The descriptions comprise the cohort means, medians and standard deviations. By locating the students' WATS and examination scores in equal class sizes, the performance profiles of the cohorts can be seen.

In addition to the students' WATS and examination performance, the timings of the students' WATS submissions have been collected. The timing of the students' submissions provide insights into the students' study patterns.

Descriptions of the students' performance and their submission times focus on individual data measurements. In contrast, regression analysis provides an opportunity to explore any potential relationships within the collected data. The nature of the relationship, positive or negative, can be seen by plotting the various measurements against each other. The strength and nature of the potential relationship is found by calculating a correlation coefficient.

Inferential statistics allows inferences to be drawn from the data. These inferences enable judgements to be made between the cohorts and support an analysis of the transportability of the sample (cohort) findings to the population. In this research inferential statistics are used to test the hypothesis that the WATS approach to assessment created a better understanding of the subject than would have existed otherwise, '*better understanding*' being judged as the students' improved performance in the module's final examination. In comparing the cohort means, the convention adopted in this research is that the null hypothesis describes a situation where no benefit arises. The null hypothesis is the default position and is accepted unless the findings, from the statistical analyses, suggest it could reasonably be rejected.

Single-tailed tests are used in lieu of a two-tailed test, since the hypothesis tested is that the WATS approach to assessment has made a *positive* difference; that is, a better understanding of the subject area. The null and alternate hypotheses are mutually exclusive.

Although the assessment activity was identical across the cohorts exposed to the WATS, each cohort would have been exposed to a unique final examination. Internal moderation procedures are in place to help ensure the examination standard is relevant for the level and consistent between cohorts.

## 4.4 Qualitative methods

Qualitative methods focus on non-numeric data. Given that the research and the research questions do not constitute a single-minded exploration for improvements in examination performance, but they also relate to the impact of the assessment programme on the students' study behaviours as well as gaining the students' perception of the usefulness of the assessment programme, there is a need to elicit data and feedback from a range of sources and research methods. This additional data complement those arising from the student performance, since they present the students' perceptions of the WATS approach to assessment and their views on how it influenced their actions and study behaviours. Questionnaires were used to gain the student view, and the students' posts to the module discussion forum were reviewed for their relevance to the research. *In situ* observational studies were discounted since the students' habitat is prohibitively vast and includes the classroom, the Learning Resource Centre, the halls of residences and other social spaces. Given the numbers of students involved in the research, meaningful observations of student behaviour within these settings was deemed impracticable.

### 4.4.1.1 Questionnaires

The primary mechanism used to collect the students' views of the assessment programme was a WATS specific questionnaire. This questionnaire comprised a series of statements specifically relating to different features of the WATS approach to assessment. The WATS related statements, featured in the questionnaire, were all presented as positive statements and students were asked to indicate their level of agreement with the statement via a rating scale.

To explicitly demonstrate to the students an equal scaling between the available choices, each position on the rating scale was associated with an integer value. The text describing the various positions of the scale and the associated integer values were presented to the students when they responded to the questionnaire. Hence, in addition to seeing the distribution of the students' responses on the rating scale, arithmetic operations could be

performed on the responses. In this case a 'weighted average' could be calculated for the students' responses to each of the statements. The weighted average allows comparisons to be made between the different statements and subsequently allows the various features of the WATS approach to assessment to be ranked according to the level of student satisfaction.

A pilot questionnaire was developed and issued to the 2002-03 cohort. The pilot questionnaire (see Appendix D) was guided by general advice on questionnaire design (Blaxter et al., 2006; Moore, 2006; Robson, 2002). Following the use of the pilot questionnaire three modifications were made. The modified questionnaire included changes to one of the questions, the method of administering the questionnaire and the number of choices on the rating scale. The three modifications are described below.

*i) Modifications to a question;* the pilot questionnaire presented the students with the statement '*I really like doing the WATS and getting a mark each week*' [emphasis added]. On reflection, this question was particularly confusing since this single statement sought a view on two separate, although related, aspects of the assessment programme. The revised questionnaire separates the statement into two individual statements. '*I really like doing the WATS each week*' and '*I really like getting a mark each week*'.

*ii) Method of administering;* the pilot questionnaire was administered by hand in a one-off teaching session. Although the response rate, 66%, was above the level that may indicate a response rate bias, 60% (Moore, 2006), this research wanted to engage more of the students exposed to the WATS approach to assessment. The modified questionnaire was subsequently administered electronically and embedded in the *WATS Data Gatherer*. This meant that limited additional effort was needed by the students to complete it. The students now responded to the questionnaire when they submitted their response to the weekly tasks. Removing barriers to questionnaire completion is recognised as essential to increase participation. Maximising participation and seeking to gain views from all the students, rather than gaining those of a self-selecting group or vociferous few, was a cornerstone of the evaluation strategy. Response rates with the modified questionnaire were 91% (121/133) 2003-04, 85% (138/163) 2004-05 and 87% (149/172) 2005-06. Gaining such a high response rate improves the credibility of the findings through reducing the potential for bias.

*iii) Rating scale;* the final modification to the pilot questionnaire centred around the number of choices on the rating scale. In the pilot questionnaire the students were presented with a

six point rating scale. This scale was labelled as shown in Table 4-1. The integer values associated with each position on the rating scale is shown below the descriptive text.

Table 4-1. Six point rating scales used in the pilot questionnaire (administered 2002-03)

		<b>&lt;-Agree</b>		<b>Disagree -&gt;</b>	
strongly agree	agree	slightly agree	slightly disagree	disagree	strongly disagree
1	2	3	4	5	6

In the pilot questionnaire the six point scale, and accompanying labels, forced the students to express a view and did not allow for a no-view or neutral position. To accommodate a neutral view the revised questionnaire used a five point rating scale. This revised scale was labelled and presented to the students as shown in Table 4-2.

Table 4-2. Five point rating scales used in the modified questionnaire (administered 2003-04 onwards)

		<b>&lt;-Agree</b>	<b>No view</b>	<b>Disagree -&gt;</b>	
strongly agree	agree	neither agree nor disagree	disagree	strongly disagree	
1	2	3	4	5	

The revised questionnaire is presented in Appendix E.

#### 4.4.2 Open responses; data collection and analysis

To provide the students with an opportunity to respond outside the closed statements of the questionnaire, the *WATS Data Gatherer* was also programmed to take open, free-text, responses. Many students chose to respond to the open question and provide short narratives of their experiences through the additional opportunity.

To gain a broad view of student experience and avoid steering the students towards any particular aspect of the assessment programme the primary question asked was:

*Now that you have finished the WATS approach to assessment what comments do you have regarding this approach to teaching and learning?*

292 responses were submitted to the question. This represents an overall response rate of 65%. The response rate was reasonably consistent for each of the cohorts. The breakdown

for each cohort was 65% (86/133 2003-04), 58% (93/163, 2004-06) & 66% (113/172) 2005-06.

Content Analysis was used to guide the investigations on the data and to help extract meanings from the students' open responses. Content analysis is a research method that helps make inferences from text (Weber, 1990). Baur and Gaskell (2000) describe how content analysis not only undertakes numeric descriptions of the text (e.g. word counts) but that these quantifications are preceded by the *kinds, qualities and distinctions* of the text. Baur and Gaskell go on to indicate that content analysis can provide a useful bridge to the quantitative and qualitative divide in social research.

To support the content analysis, a spreadsheet was programmed to tally the occurrences of keywords in the students' responses. For ease of visibility, conditional formatting was used to colour-code the spreadsheet cells where the keywords appeared. The highlighted keyword guided the analysis to a *key word in context* (kwic) study (Baur & Gaskell, 2000), looking at the context in which the key word was written. The kwic study formed the basis of a thematic investigation of the open responses.

Two methods were used in the thematic investigations; *a priori* coding and *a posteriori* coding. *A priori* coding used the predefined research questions, with the students' responses read and tagged according to their relevance to the research questions. The open responses were read to look for relevance to study patterns, impact on examination, pastoral support and teaching. In addition the responses were read to see if the students' response indicated a positive and/or negative view about the assessment programme. The students' responses were stored, analysed and tallied in Microsoft Excel. An example coding table is shown in Table 4-3.

Table 4-3. Example coding of student responses (coding against having a positive comment and / or negative comment)

<i>Example student responses</i>	<i>Positive</i>	<i>Negative</i>
a helpful way of ensuring you follow the course.	1	
a highly stressful experience! seriously!! but i can say its better than having a heavier weighted exam paper. it felt good to know how you were doing week by week, especially when you were doing well. being assessed throughout a course instead of all at the end is a much better way to see how well someone is doing. that especially applies to me.	1	
according to me it is an excellent way of teaching both for teachers as well as students. hope it should be introduced in other subjects as well. well done -- that's what i will say at the end..	1	
an excellent way to ensure students are doing work outside of lessons every week however would be a lot more motivated if there were method marks so there was less to worry about when entering in digits.	1	
good but tedious towards the end. and too hard when it doesn't relate to any of the tutorial work.	1	1
good idea because it helps you to take everything in easier. shame working marks cannot be awarded if final answer is wrong	1	1

A *posteriori* coding used an alternate approach. In a *posteriori* coding the themes emerged from reading the students' responses. A *posteriori* coding is consistent with grounded theory where the themes emerge from, or are '*grounded*' in, the data (Glaser & Strauss, 1967).

The codes for a *posteriori* coding were developed iteratively from an initial review of the students' posts. The students' posts were then re-reviewed to see if they also had a view, agreement or other, with the emergent codes. Using an emergent a *posteriori* coding approach, where the items of interest come from the students rather than the researcher, does not constrain the findings to the original research questions but provides opportunities to gain other views and establish themes that might not have been considered *a priori*. Although this has the potential to broaden the research further, it is a little more open-minded and provides opportunities to hear the students' varied experiences and perceptions. The students' responses are not now constrained to respond to the interests of the researcher as set out in the research questions. Consistent with grounded theory, the a *posteriori* analysis starts with the data, identified codes and developed broader categorisations of responses.



#### 4.4.3 Additional qualitative data: Contributions to the discussion forum and e-mails

The discussion forum associated with the module was used to support the ongoing assessment programme. The discussion forum received many posts relating to the specifics of the weekly tasks. These posts were reviewed for their relevance to the research. In situations where students posted more general comments and observations relating to the assessment programme, these were collected and stored for categorising against the emergent codes described in Section 4.4.2. Additionally, unsolicited e-mails received from the students were also collected and coded.

#### 4.5 Student bias

To explore the potential for a 'performance bias', the students' responses to the questionnaire were correlated against their WATS score. Due to the questionnaire scoring system and the fact that the questions were presented in the positive, a negative relationship will indicate a performance bias. In this research a performance bias indicates that students gaining high marks on the WATS will rate the assessment as favourable.

The students' free-text responses were classified against their WATS performance. For each cohort, three discrete Performance Groups were identified:

- Performance Group 1 students in the top half of cohort who passed the WATS;
- Performance Group 2 students in the bottom half of the cohort who passed the WATS;
- Performance Group 3 students who failed the WATS.

In addition to coding the free-text responses (against the research questions), the tallies of coded responses were compared with the Performance Groups. This comparison will indicate if students from different Performance Groups describe a different perspective of the assessment programme. An example of the Performance Groups' distribution for positive and negative attributes of the assessment programme is shown in Table 4-4.

Table 4-4. Example positive and negative responses against Performance Groups (2004-05)

<i>Performance Group</i>	<i>Positive</i>	<i>Negative</i>
1 n (%)	28 (90)	12 (39)
2 n (%)	41 (91)	21 (47)
3 n (%)	16 (94)	8 (47)

## 4.6 Interviews

One-to-one interviews were not used throughout the study due to the number of students involved. However, following the students' performance in the 2005-06 examination, a series of one-to-one interviews were conducted. Ten students volunteered to participate in semi-structured interviews. The interviews were conducted by an independent researcher and lasted approximately one hour.

The interview was singly focused on the Fluid Mechanics and Thermodynamics module and addressed the following categories:

- Organisation/structure, guidance from lecturers
- Work done in class
- Use of available resources
- Time spent on the module
- Performance on the module
- Factors contributing to students learning and performance
- How the students studied the module
- Feelings about the complexity of the module and its subject areas

While the interviews were not part of this research, the interview transcripts were explored for their relevance.

## 4.7 Data storage

Microsoft Excel was the primary tool used for storing the raw data. For each of the cohorts a Microsoft Excel Workbook was used to store:

- The students' WATS scores
- The date and time each student submitted their response to the weekly task
- The students' examination scores
- The WATS League Table
- The students' responses to the questionnaire
- The students' free-text responses.

Additionally the Microsoft Excel Workbook was used to undertake and store analyses on the raw data. These analyses included:

- Descriptive data of Examination and WATS performance;
- Ranking students according to their Performance Group;
- Correlations between data sets;
- Examination performance and WATS scores;
- Examination performance and questionnaire responses;
- Performance Group and free text coding.

## 4.8 Ethical considerations

For research studies involving the use of human participants the University of Hertfordshire have a defined University Policy and Regulation (UPR RE01). The policy describes the regulations and identifies the notion of an Ethics Committee with Delegated Authority (ECDA). The ECDA considers requests to undertake research involving human participants within their disciplinary area. In relation to this research, approval was sought and granted to undertake the work by the ECDA for the Faculty of Engineering and Information Sciences (FEIS). In the case of the FEIS ECDA, a completed questionnaire is needed. The questionnaire requires a description of the work, and sets out to safeguard the students participating in the study and the data arising from the study. The approved protocol references relating to the research are:

03/45 Evaluation of the 'WATS' project

06/102 Understanding students' learning behaviours on an Engineering module

0910/84 WATS approach to assessment – a synthesis for PhD submission

## 4.9 Summary of data and research methods

To consolidate the preceding discussions, a summary of the research methods used, together with the data collected and the analysis undertaken, is presented in Table 4-5.

Table 4-5. Summary of data and research methods used in the evaluation

Research theme/question	Data collected	Analysis
What impact did the assessment programme have on the student study behaviours?	Timings of the students' submissions to the <i>WATS Data Gatherer</i>	Correlations of timings with performance.
	Observation of contributions to the discussion forum	Timings and nature of the contributions.
	Free-text in the WATS questionnaire	Study profiles in the students' own words.
	Unsolicited e-mails	Analysis of text and demonstration of impact; timing and nature of the e-mails.
	WATS League Table	Performance and submission profiles.
	Interview transcription	Analysis of student responses.
What impact did the assessment programme have on student performance?	Student performance in the WATS (League Table)	Profiles of student performance. Difficulty of each task.
	Examination performance	Descriptive and inferential statistics. Correlations of WATS and Examination Performance. WATS as a predictor of examination success. Which group are most likely to benefit from WATS-type interventions.
	Free-text in WATS questionnaire	Impact on performance in the students' own words.
What impact did the assessment programme have on teaching and the provision of learning oriented support?	WATS performance (League Table)	Use of data to provide evidenced based teaching adaptations. Calculations of difficulty of task.

What was the students' perception of the usefulness of the assessment programme?	Questionnaire (closed questions)	Features of WATS that students prefer and value as being learning oriented.
	Free-text – open question	Theming of responses - content analysis.
	Discussion forum	Theming of responses-content analysis.
What impact did the assessment programme have on student support?	WATS performance (League Table)	Identifying at-risk students and study profiles.
	Incoming e-mails	Nature of incoming e-mails and theming.

#### 4.10 Close of Chapter Four

Good research demands a purposeful and considered evaluation strategy. The evaluation strategy and the framework within which the research operates should be influenced by the research problem, the audience for the research and the competency of the researcher.

The approach taken in the evaluation phase of this research has been one that sought to ensure the validity, reliability and authenticity of the findings. This manifests itself by:

- giving all the students an opportunity to have a voice;
- consideration of views from different research methods;
- triangulating the findings;
- considering data across cohorts;
- seeking students' views within and outside formal feedback questions;
- using questions that were non-threatening to the student;
- removing barriers to gaining the student view.

Input from peers has tested the developing conclusions and the development of the assessment programme. Lessons learnt have been fed back to the assessment programme with year-on-year developments.

## 5 Results and preliminary discussion

The WATS approach to assessment was presented in Chapter Four. The development of the assessment programme was brought about to respond to the observed lacking student engagement and poor examination performance in Fluid Mechanics and Thermodynamics. Analysis of the literature, the local context, the module and the student group, gave rise to a set of complementary design themes and supporting principles. The design themes and principles, set out in Chapter Two, were used to steer the development of the assessment programme.

The intended consequence to flow from the development, guided by the design themes, was to improve student learning and teaching on the module. Hence the thesis presented argues that the WATS approach to assessment will enhance both learning and teaching.

This chapter presents the results from the implementation of the WATS approach to assessment. In responding to the thesis the results are presented against:

- i) the impact of the assessment programme on student support;
- ii) the impact of the assessment programme on student study behaviours;
- iii) the impact of the assessment programme on teaching and the provision of learning oriented support; and
- iv) the impact of the assessment programme on student performance.

The voice of the student concludes the chapter.

### 5.1 The impact of the assessment programme on student support

Student support is viewed here as having two separate functions. First, the support that is more purposely learning oriented and intimately connected with the teaching function, and second the support that is more obviously associated with the students' well-being and their ability to engage with the learning. While some aspects of student support blur the distinction, this section deals with the information generated by the assessment programme relating to the students' well-being and their availability to learn. The impact of the assessment programme related to learning oriented support is discussed separately in Section 5.3.

### 5.1.1 Monitoring student engagement

An overview of the ongoing student performance can be seen in the *WATS League Table*. Two alternate views of the *WATS League Table* are possible, a student-by-student (row) view and a task-by-task (column) view. For student support the league table is best viewed on a student-by-student basis (row view). In addition to highlighting the students' comparative performance, the student-by-student view highlights those individual students that appear to be struggling with the subject (colour coded red) and those that are not (colour coded green). The colour coding is undertaken automatically and is dependant on each student's ongoing performance. In addition to highlighting the individual student's performance, the student-by-student view indicates their engagement with the weekly tasks. This information provides useful evidence on which to initiate discussions regarding the student's study patterns and their impact on the student's performance. Examples of different student engagement are discussed below (see also Table 5-1). A non-submission of a weekly task is indicated by a score of 0 (zero) whereas a submission scoring zero marks is recorded as a score of 1 (one).

Table 5-1 Fragment of the weekly WATS performance (2003-04)

ID	WATS number											WATS	Last weeks	This weeks
	1	2	3	4	5	6	7	8	9	10	11	Av	Rank	Rank
LAO	44	86	57	62	50	33	0	0	59	1	1	36	124	128
COM	33	57	1	0	67	42	0	14	64	15	0	27	136	136
KHM	0	0	0	62	0	0	7	57	64	62	0	25	137	137

The level of engagement and success from student LAO (highlighted yellow in Table 5-1) is different in the second half of the semester than it was in the first. LAO's first six tasks were submitted with pass or near pass scores. LAO only submitted three of the last five tasks, only one of which achieved a pass mark (WATS 9 = 59%). The other two submissions scored zero marks (WATS 10 & 11). Even though this might indicate a reversal in personal interest or motivation, it might also indicate the emergence of an issue impacting on LAO's ability to engage with the module.

LAO's profile contrasts with his near neighbour COM (highlighted green). COM's submission profile is seen to be irregular throughout the semester. COM does not submit a response to WATS 4, 7 or 11. This might suggest an ongoing issue influencing his ability to engage with the module or simply COM's adoption of an entirely inappropriate study pattern. Further, of the eight tasks that COM submitted, only four achieved a pass mark.

Student KHM's profile (highlighted blue) differs again from LAO and COM. KHM only submitted a response to five of the WATS and didn't make his first submission until week 4 (WATS 4).

What is useful in the examples noted is the immediacy and visibility of the emerging performance and engagement information. In the three cases noted, LAO, COM and KHM, the *League Table* presents sufficient and immediate information upon which to build a dialogue. Rather than speculate causation, the information allows for timely discussions to help identify the cause of any potential issue and ultimately suggest changes to study behaviours or offer appropriate student support.

### 5.1.2 Stimulating additional teacher-student contact

The assessment programme provides a prompt and personalised feedback e-mail to each of the students registered on the module. This feedback e-mail provides the scores to those students who submitted work and a '*did not submit*' e-mail to those students who did not respond to that week's task. The provision of a '*did not submit*' e-mail appears to do two things. It stimulates the student to re-engage with the subject and also presents the recipient with an invitation to discuss their non-submission. Evidence of this stimulated response to the '*did not submit*' e-mail is given below.

*I apologise for not submitting the last two WATS papers, I have had some family issues that have required my full attention these last few weeks. These issues have now been resolved, i can assure you that i will not fail to hand in the following WATS papers. e-mail*

*i have a reson for the non submission of wats sheet 1 cuz my sister was havin her delivery and i had to look after her for nearly 2 weeks .so, plz sir, it would be great if u allow me to submit my sheet any day u like. and sir, due to some personal problems, i will not be able to attend the lectures from 6th feb till 20th feb cuz i have to go back to my home in India. so , sir plz, if thr is any submission required, i will deposit it after 21st. plz sir (sic) e-mail*

*I sorry that I didn't submit my WATs but I have reason why I couldn't submit my WATs on Tuesday (30/01/07) because I am seriously ill; I did try to inform you by phone but couldn't speak due to my sore throat. I have evidence that I am ill by asking you to ring my doctor because I visited him on that Tuesday at 11am*



*as an emergency appointment. With your permission can I submit my WATs to you by hand next week Monday or give it to you when I submit the next WATs sheet on Tuesday. (sic) e-mail*

The examples above provide an additional opportunity to offer the students advice and support as they engage with their studies.

The instruments developed to support the assessment process provide numerous opportunities to support both the students' learning and the teacher's teaching. Although not dominant in the original development they also, as indicated above, provide information on the students' engagement. This additional information stimulates an additional opportunity to support the students as issues arise that might impact on their availability to learn.

The following section describes the impact of the assessment programme on the students' study behaviours. The results comprise data drawn from the students' engagement with the weekly tasks and their engagement with the module discussion forum.

## 5.2 The impact of the assessment programme on student study behaviours

### 5.2.1 Engagement with the weekly tasks

The number of students submitting a response to the weekly task is shown in Table 5-2. The first column for each cohort represents the total number of students who submitted a response, whereas the second column represents the number of submissions made by the students who took the final module examination. The bracketed figure represents the percentage of students responding.

High proportions of each cohort were actively engaging with the module each week. Further, the students' engagement was focused on tasks that were i) aligned with the learning outcomes; ii) consolidating the current lecture and ii) distributed across the subject domain and the semester. All these qualities are aligned with the principles underpinning the development set out in Chapter Two.

Table 5-2 Cohort submission profile\*

	2002-03		2003-04		2004-05		2005-06		All Years	
	Total	Sat exam	Total	Sat exam	Total	Sat exam	Total	Sat exam	Total	Sat exam
WATS 1	122 (95%)	118 (92%)	133 (100%)	124 (93%)	156 (96%)	147 (90%)	173 (101%)	167 (97%)	584 (98%)	556 (93%)
WATS 2	123 (96%)	119 (93%)	134 (101%)	125 (94%)	160 (98%)	151 (93%)	165 (96%)	159 (92%)	582 (98%)	554 (93%)
WATS 3	119 (93%)	115 (90%)	132 (99%)	124 (93%)	158 (97%)	151 (93%)	171 (99%)	166 (97%)	580 (97%)	556 (93%)
WATS 4	114 (89%)	110 (86%)	129 (97%)	121 (91%)	159 (98%)	153 (94%)	165 (96%)	162 (94%)	567 (95%)	546 (92%)
WATS 5	116 (91%)	112 (88%)	135 (102%)	127 (95%)	159 (98%)	153 (94%)	170 (99%)	163 (95%)	580 (97%)	555 (93%)
WATS 6	116 (91%)	111 (87%)	134 (101%)	124 (93%)	150 (92%)	144 (88%)	160 (93%)	154 (90%)	560 (94%)	533 (89%)
WATS 7	122 (95%)	117 (91%)	128 (96%)	122 (92%)	143 (88%)	136 (83%)	159 (92%)	155 (90%)	552 (93%)	530 (89%)
WATS 8	116 (91%)	112 (88%)	129 (97%)	123 (92%)	142 (87%)	140 (86%)	149 (87%)	148 (86%)	536 (90%)	523 (88%)
WATS 9	83 (65%)	81 (63%)	114 (86%)	110 (83%)	139 (85%)	138 (85%)	158 (92%)	157 (91%)	494 (83%)	486 (82%)
WATS 10	96 (75%)	92 (72%)	119 (89%)	113 (85%)	131 (80%)	131 (80%)	154 (90%)	154 (90%)	500 (84%)	490 (82%)
WATS 11	94 (73%)	91 (71%)	112 (84%)	106 (80%)	136 (83%)	136 (83%)	150 (87%)	150 (87%)	492 (83%)	483 (81%)
Sum WATS	1221	1178	1399	1319	1633	1580	1774	1735	6027	5812
Average	111 (87%)	107 (84%)	127 (95%)	120 (90%)	148 (91%)	144 (88%)	161 (94%)	158 (92%)	548 (92%)	528 (89%)
<i>n exam</i>	128		133		163		172		596	

\* Percentages higher than 100% indicate that at that time more students submitted the work than took the examination.

There is a decline in the number of submissions as the weeks progress. The rate of decline differs within the cohorts (see Figure 5-1). Students ranked in the upper third of the cohort, as measured by their examination score, maintained a reasonably consistent level of engagement as the weeks progressed. The rate of decline was less than 0.7% per week ( $r = -0.84$ ). Students ranked in the lower third of the cohort exhibited a rate of decline in the rate in submissions of more than 2% per week ( $r = -0.96$ ).

Figure 5-1 Student responses versus WATS (all cohorts)

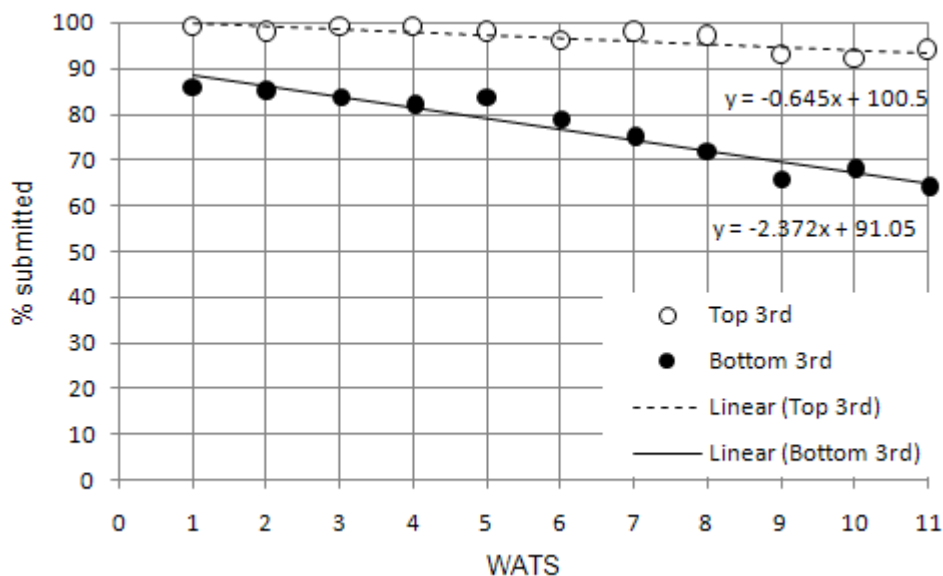

### 5.2.2 Day of submission

In addition to collecting and storing the students' responses to the WATS, the *WATS Data Gatherer* also collects and stores the date and time the students submitted their data. Collecting the date and time allows for additional analysis to be undertaken, i.e. the length of time before the deadline the students submitted their responses, and exploration of a relationship between the students' performance and the length of time before the submission deadline.

The number of submissions made a day or more before the submission deadline is presented in Table 5-3. The data is constrained to the years 2003-04, 2004-05 & 2005-06 since only these cohorts submitted their results through the *WATS Data Gatherer* and hence the date and time of submissions could be recorded. (The *WATS Data Gatherer* was not available in 2002-03).

Table 5-3 Number of WATS submissions made at least a full day before the submission deadline

	2003-04	2004-05	2005-06	all years
<i>Day in advance</i>	108 (7.7%)	193 (11.8%)	236 (13.3%)	537 (11.2%)
<i>Total submissions</i>	1395	1631	1773	4799

Across all years only 11% of the total number of submissions were made a full day before the submission deadline. This figure is similar for each of the cohorts (8% 2003-04, 12% 2004-05, 13% 2005-06). While the majority of the students' submissions were made on the last day of the weekly study period, which might indicate cramming, there is evidence on each cohort's discussion forum that some students were thinking about and working on the tasks in the days preceding their submission. For instance, the following was posted to the discussion forum on the 18th February 2004 and yet the student chose not to submit his results until the 24th February 2004; the last day of that week's study period.

*To Mark Russell, The last WATS 3 question is unclear what is meant by the horizontal floor of the tank, how is it different to the original position of the door.  
(S58, 2003-04)*

Further, the following was posted on the 14th April 2005 whereas the student chose to submit on the 26th April 2005.

*I was attempting Watts 9 and i got stuck on the first question because I found there was 2 unknowns when equating equations for both size disk in different fluids. The only assumption i could come to was there should be an angular velocity given in the question for the first disc in the equation so that we can find the Dynamic Viscosity for the fluid for second disc. Hope this is clear (2004-05)*

The first example demonstrates thinking about the task whereas the second demonstrates, by the student's own admission, working on the task. Both comments were posted to the discussion forum in the days preceding the submission deadline and the students' actual dates of submission.

### 5.2.3 Time of submission

There is evidence to suggest some of the students were working on the tasks in the days preceding their submission and not just on the day of the submission deadline. It is instructive, however, to also look at the time of the students' submissions. Since this assessment exploits technology to collect the students' submissions, the submission deadline is not constrained to fall within normal working hours; i.e. 09.00-17.00. The submission deadline was purposely set at midnight on the submission day. During the first year of deployment (2002-03), prior to the development of the *WATS Data Gatherer*, students were required to submit hard copy responses to the Administrative Office. As such, the deadline for receipt of submissions was during office hours, a consequence of which was some students missing lectures so that they could work on their WATS task. The development of the *WATS Data Gatherer* presented opportunities to use submission deadlines outside office deadlines.

A histogram showing the time the students submitted their work is shown in Figure 5-2. The histogram relates to 2004-05 and is typical for the three years where the date and time of submissions has been recorded. A summary of the submission time profiles for all the cohorts is presented in Table 5-4.

Figure 5-2 Submission times of the WATS (2004-05)

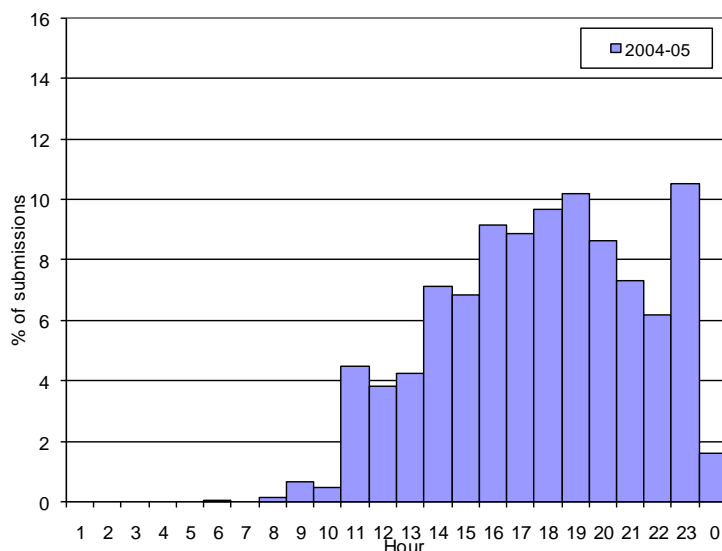

Table 5-4 Submission times of the WATS – located in various time bands

	2003/04	2004/05	2005/06	All years
9-5 inc	699 (50.1%)	745 (44.5%)	851 (48%)	2295 (47.8%)
Outside 9-5	696 (49.9%)	886 (55.5%)	922 (52%)	2504 (52.2%)
Within last two hours	244 (17.5%)	273 (16.3%)	244 (13.8%)	761 (15.9%)
Within last hour	135 (9.7%)	172 (10.3%)	137 (7.7%)	444 (9.3%)
Total submissions	1395 (100%)	1631 (100%)	1773 (100%)	4799 (100%)

Around half the students chose to submit their responses outside normal office hours. The results also show that around 16% of the submissions were made within the last two hours of the study period, i.e. two hours before the midnight submission deadline. Furthermore, around 9% of the submissions were made within the last hour of the study period. The figures quoted are similar for all the cohorts.

In addition to submitting a response to the task the students have been stimulated to think about and work on the task prior to the submission deadline. The module discussion forum provides additional insights into the students' activity and engagement.

#### 5.2.4 Engagement with the discussion forum

Two members of the teaching team were particularly keen to utilise *StudyNet* and the discussion forum associated with the module. The intention was to provide an additional opportunity for the students to discuss their work. The discussion forum was initially used

(2001-02) to both extend and enhance the classroom activity. A review of the 2001-02 use of the discussion forum shows that, while only 10% of the students were posting items, 50-60% of the students found the discussion forum useful (Bullen & Russell, 2007). Following the introduction of the WATS approach to assessment, the discussion forum was additionally used to support the assessment activity. There was already evidence that the students would engage should it seem to be of use to them and their studies.

In addition to presenting the students' submission profiles, the following shows the students engaging with each other via the discussion forum. The level of engagement shown in Table 5-5 starts to display an alternative view of student behaviour and provides an additional insight into the students' study patterns as they respond to the weekly tasks. Mechanical Science<sup>9</sup> is chosen as a comparator since it is similar in its application of science and mathematics, is a first year module and is taken by the same group of students.

Table 5-5 Number of contributions made to the module related discussion forum

	2001-02		2002-03		2003-04		2004-05		2005-06	
	F&T	Eng Sci*	F&T	Mech Sci	F&T	Mech Sci	F&T	Mech Sci	F&T	
Number of posts to discussion forum	70	57	97	0	105	39	693	21	443	
Number of threads	30	36	30	0	30	15	83	3	67	
Teacher initiated threads	14	1	19	0	18	0	3	1	2	
Student initiated threads	16	35	11	0	12	15	80	2	65	

\* Sems A&B

\* 19 threads relate to forming groups

Summing the number of student contributions to the Fluid Mechanics and Thermodynamics discussion forum, 2002-03 - 2005-06, equates to 1758 posts. This contrasts with 225 made to the comparative module for the same period. The majority of the contributions to the Fluid Dynamics and Thermodynamics discussion forum indicate the students were thinking about the WATS and the module. Such visible thinking and working was not as evident on other module discussion forums. Indeed, while Engineering Science received 57 contributions in 2002-03, 19 of the 35 threads (53%) were associated with the formation of groups and not the learning materials or learning *per se*.

---

<sup>9</sup> Engineering Science was the forerunner to Mechanical Science

### 5.2.5 WATS encourages active engagement - the student voice:

To complement and conclude section 5.2, *the impact of the assessment programme on student behaviours*, and the observed student engagement, the following presents sample quotations from the students relating to the students' engagement. The quotations complement sections 5.2.1 - 5.2.4 and demonstrate the students' perception of the impact of the assessment programme on their study behaviours.

*This way of teaching forces the student to take part in studies which they would not normally participate in and i believe it is a good idea for revision and understanding a subject which i never learnt before.*

*I think wats was a good thing as it has made us all review our notes and revise throughout the semester instead of throwing on the floor and not looking at them until the exam (S78, 2003-04).*

*I think it is a good approach to learning because it enables or rather "forces" us to work on the module every week, and this kind of helps sometimes (S100, 2003-04).*

*it actually makes you do the work, or basically we are forced to do it also makes us learn what were doing (S62, 2005-06).*

Finally, in response to a post to the discussion forum which sought to remind the students the value of the WATS,

*This, by the way, is the value of the WATS. They encourage you to ask smart questions at the right time*

one student responded,

*That's right, I wouldn't bother looking all this up if there was no WATS (and questions on StudyNet). Posted to StudyNet*

Section 5.2 presented the impact of the WATS approach to assessment on the students' study behaviours. There are consistently high numbers of students engaging with the weekly tasks (see Section 5.2.1), and also a visible trace of student thinking and engagement on the tasks in the days preceding their submissions (see Section 5.2.2). Around half the students exploited the affordances provided by the technology and submitted their work outside normal working hours. There are concerns about the timing of some of the student responses, with a consistent 10-15% of the students choosing to submit their work two hours

before the midnight submission deadline. In addition to viewing the date and time of submissions and the number and nature of contributions made to the discussion forum, students have commented that the WATS approach to assessment stimulated their engagement with the module in a way that otherwise may not have occurred.

The importance of alignment, as identified in the theme 1 underpinning the development, includes principles that the assessment supports, and becomes an integral part of, the teaching and learning settings (principle 2) and that it also informs teachers of the students progress (principle 3). Such principles make clear the important relationship between the WATS approach to assessment and the ongoing teaching and learning oriented support. The following section describes that relationship and demonstrates the interplay between the assessment programme and the teaching and learning oriented support.

### 5.3 The impact of the assessment programme on teaching and learning oriented support

Chapter Two set out the view that teaching is a considered and structured process that stimulates appropriate and meaningful student activity. Further, this structured activity integrates the requirements of the curriculum together with the demonstrable needs of the students. To combine the demands of the curriculum with those of the students requires information on what those needs are. This information, in this assessment programme, is available in various guises and is presented below.

#### 5.3.1 WATS League Table

The primary instrument used to display the demonstrable needs of the students is the *WATS League Table*. The *WATS League Table* records the students' ongoing performance on the weekly tasks. In contrast to the student-by-student view, which offers the potential to instigate a student support dialogue, as presented in Section 5.1, the task-by-task view of the *WATS League Table* highlights the cohort's understanding of the weekly topic areas. Eliciting the students' understanding is a central requirement for student-centred and adaptive teaching. The *WATS League Table* is used and made visible to the students to enhance learning by; stimulating social competition; providing instant feedback; enticing the students back to *StudyNet*; and presenting the students with an opportunity to be seen to be learning.



A fragment of a *WATS League Table* is presented in Table 5-6. The students' performance on WATS 2 and WATS 9 are highlighted.

Table 5-6 Fragment of the *WATS League Table*; task-by-task view highlighted 2003-04

ID	WATS number											Av	Last weeks Rank	This weeks Rank	Change in Position
	1	2	3	4	5	6	7	8	9	10	11				
JPN	100	100	100	62	100	83	100	57	27	77	100	82	22	18	up 4 place(s)
AUT	78	100	100	100	100	50	90	86	1	100	100	82	23	19	up 4 place(s)
GUM	78	100	100	100	83	83	100	93	0	95	100	82	24	20	up 4 place(s)
CMR	78	86	100	100	100	88	60	86	45	58	100	82	25	21	up 4 place(s)
ESH	100	86	86	100	100	67	93	64	1	100	100	82	26	22	up 4 place(s)
LBN	67	100	100	62	83	92	63	100	64	81	83	81	19	23	down 4 place(s)
COL	89	71	86	88	100	75	97	86	100	31	67	81	17	24	down 7 place(s)
GUF	100	100	100	62	100	100	73	93	0	62	100	81	27	25	up 2 place(s)
JAM	78	100	100	62	58	92	63	0	14	77	0	59	76	93	down 17 place(s)
BLZ	67	100	86	1	83	58	33	86	14	15	100	58	105	94	up 11 place(s)
LIE	67	100	29	62	17	33	87	57	73	15	100	58	106	95	up 11 place(s)
MUS	78	100	86	0	83	100	47	57	0	85	0	58	78	96	down 18 place(s)
ITA	78	93	71	46	100	58	60	29	0	31	67	58	97	97	up 0 place(s)
AND	33	100	100	54	67	75	23	86	41	38	0	56	82	98	down 16 place(s)
BH	100	100	29	62	100	92	47	86	0	0	0	56	83	99	down 16 place(s)
CHL	67	86	71	62	67	0	13	0	1	62	0	36	119	124	down 5 place(s)
GRL	44	100	29	77	17	67	17	67	5	15	0	36	120	125	down 5 place(s)
DJI	0	100	86	77	50	0	57	57	0	0	0	36	121	126	down 5 place(s)
BRA	0	100	0	46	0	83	60	29	0	0	100	36	133	127	up 6 place(s)
LAO	44	86	57	62	50	33	0	0	59	1	0	36	124	128	down 4 place(s)
BOL	44	57	0	100	100	50	7	1	1	31	0	36	125	129	down 4 place(s)
MDV	61	100	29	46	100	38	0	0	1	15	0	36	126	130	down 4 place(s)
N(s)	133	133	131	120	134	134	128	127	109	119	109				
Mean(s)	76	92	77	72	75	72	71	63	36	61	85				
Median(s)	76	100	86	73	83	75	80	64	27	62	100				
SD(s)	19	15	30	25	28	24	27	32	32	30	23				
D100(s)	0.76	0.35	0.54	0.67	0.58	0.84	0.85	0.83	0.96	0.81	0.35				
D75(s)	0.34	0.14	0.36	0.52	0.38	0.40	0.45	0.54	0.83	0.57	0.33				
D66(s)	0.25	0.06	0.25	0.46	0.28	0.34	0.36	0.51	0.82	0.55	0.11				
D50(s)	0.14	0.02	0.21	0.23	0.14	0.17	0.22	0.30	0.70	0.34	0.09				
N(e)	133	133	133	133	133	133	133	133	133	133	133				
D100(e)	0.77	0.38	0.57	0.72	0.59	0.83	0.86	0.83	0.98	0.83	0.50				
D75(e)	0.38	0.19	0.41	0.60	0.41	0.42	0.50	0.56	0.86	0.62	0.48				
D66(e)	0.29	0.12	0.31	0.55	0.32	0.36	0.42	0.54	0.86	0.61	0.31				
D50(e)	0.20	0.09	0.27	0.34	0.18	0.21	0.29	0.36	0.77	0.41	0.29				
r(e)	0.36	0.19	0.48	0.03	0.35	0.52	0.38	0.48	0.09	0.52	0.39	0.59			

Observations from the students relating to the use of the *WATS League Table* include -

*It feels that even though it's a first year course, you really need to work hard to earn the grade you want. That is exactly what WATS is, something that students have that they can 'show off' with. The league table is the best factor of it. (42, 2006-07)<sup>10</sup>*

*The league table makes it competitive between students, so everyone wants to win it and therefore studies hard. Simple idea, very effective. More modules should use WATS (77, 2006-07)<sup>1</sup>*

<sup>10</sup> Emphasis added

*I think WATS is a good idea for all lectures to adopt. I particularly like the league table approach as it is always fun being competitive with your mates and taunting them when you win! It has helped me remember things and it means you have to re-teach yourself again so you remember it for longer. (S63, 2006-07)*

These student quotes support the notion of healthy competition that the *WATS League Table* sought to create. Additional evidence on the student interest in the league table can be found by reviewing the number of student unique accesses to the resource, see Table 5-7. In all cases more than half the cohort accessed the resource and seven of the nine league tables were accessed by over two-thirds of the cohort.

Table 5-7 Number of student unique accesses to the *WATS League Table* (2006-07)

	WATS Number												
	1	2	3	4	5	6	7	8	9	10	11	12	
Number of accesses	120 (70%)	143 (83%)	129 (75%)	128 (74%)	116 (67%)	100 (58%)	123 (72%)		125 (73%)			108 (63%)	
Ds(50)	0.10	0.16	0.15	0.36	0.04	0.20	0.04		0.18			0.41	0.13

Note: WATS 8, 10 & 11 were not used in 2006-07

Although the *League Table* has undoubtedly stimulated the interest of the student and brought about the potential to increase learning, the following section describes how it, and other instruments, can be used to support the teaching.

### 5.3.2 Adapting teaching sessions

The cohort understanding of the weekly topic can be seen by looking down a column of the *League Table*. Indicators of cohort understanding are highlighted by the descriptive statistics presented at the bottom of Table 5-6. These are useful to stimulate reflections of the performance of the assessment tasks to differentiate the students (see Section 5.3.4). Note, for instance, that the students displayed a better understanding of the topic covered in WATS 2 (mean 92%) than they did in WATS 9 (mean 36%).

In addition to constructing the *League Table*, the *WATS Marking Wizard* records and displays the number of students scoring full marks for each question part, for each week's task (see Figure 5-3).

Figure 5-3 Student performance; question by question (WATS 11 2005-06)

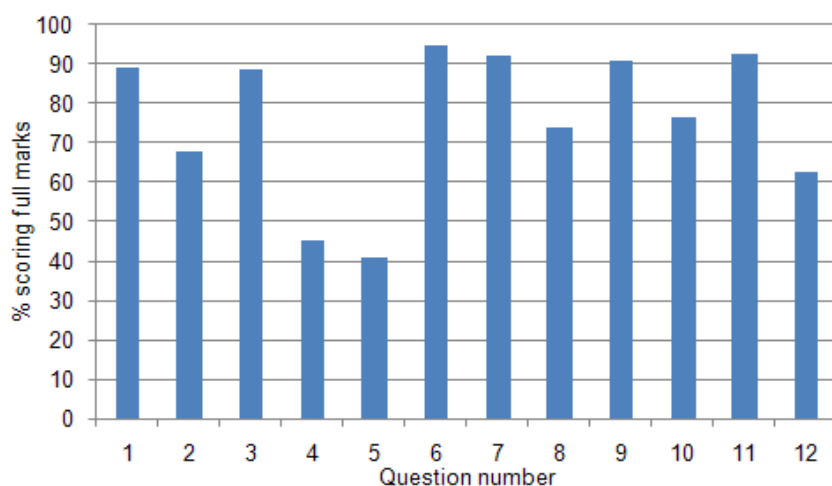

The histogram provides a finer level of granularity of the students' understanding of the different parts of the weekly task than that shown by the league table. An insight into the cohort understanding *within the weekly topic* is possible by reviewing the histogram. The histogram provides information on the constituent parts of the topic that the students appeared to understand and which they did not. In the example presented in Figure 5-3, over 80% of the students correctly responded to questions 1, 3, 6, 7, 9 and 11. This contrasts against less than 50% of the cohort correctly responding to questions 4 and 5.

The addition of free-text data collection within the *WATS Data Gatherer* provides an additional opportunity to gather evidence on the students' conceptions and their developing understanding of the subject. These conceptions are stored in a text file and illuminate the students' ability to articulate their understanding. This is different from the students undertaking calculations in an attempt to apply their understanding to solve problems. A sample of the students' responses to the question, '*in your own words please describe the continuity equation*' is provided in Table 5-8. The information collected demonstrates different levels of understanding and articulation and can be gainfully used to relate to different levels of a taxonomy such as the SOLO taxonomy (Biggs & Collis, 1982).

Table 5-8 Example free-text responses (2005-06)

72	is that the M L and T stuff?
16	Its an equation which continues a lot
170	in a moving fluid mass is conserved. therefore both velocity and density remain constant, on inflow and outflow of a restrictive plate.
185	The total mass in a closed system cannot change, therefore if the flow in a system is steady, the mass entering equals the mass leaving the system.
24	In a closed system, pressure, area and velocity are all linked together
101	This is an energy equation.
142	The continuity equation is a cut down equation of bernoulli's equation, because since the potential energy is constant all the way through the pipe because it was horizontal. The potential energy equation could be dropped from the equation. This way we could still find the velocities necessary to find 'C'.
1	the amount of mass flow per second is conserved so basically all mass that enters a pipe leaves it
152	the continuity equation means that everything continues in a system and there are no losses they are just transferred, for example if you have a low input pressure and large area which then moves to a small area, to keep continuity the pressure will have to increase to balance.
175	the continuity equation is a use of the conservation of energy, saying that the energy involved in a process can not be created or destroyed, only change from
78	All energy which is put into a system must equal the energy leaving a system
180	the continuity equation is about the conservation of energy....so whatever goes in should come out and no energy should be lost, it should just change form.
149	$\rho A_1 V_1 = \rho A_2 V_2$ $\rho$ denotes rho
141	The continuity equation states the principle of the conservation of mass for a steady flow with one inlet and one outlet. It shows that the density of a fluid multiplied by its mass and volume through an inlet, is equal to the density multiplied by its mass and volume through an outlet.
192	When a fluid is in motion, it must move in such a way that mass is conserved. To see how mass conservation places restrictions on the velocity field, consider the steady flow of fluid through a duct (that is, the inlet and outlet flows do not vary with time).
93	When a fluid moves, it must move in such a way that mass is conserved. To understand how mass conservation puts restrictions on the velocity field, then it would be a good idea to look at the steady flow of fluid through a pipe
99	Assuming density is constant, it means that flow out = flow in (plus any accumulation). This is true for volumetric flow, and therefore mass flow rates. $Q = u(1)A(1) = u(2)A(2)$
65	A continuity equation expresses a conservation law by equating a net flux over a surface with a loss or gain of material within the surface.
153	This describes the inverse relationship between cross sectional area and velocity in a pipe section. It states that the discharge (Q) remains constant through a pipe, due to conservation of mass, therefore $Q = vA$ . Because $vA$ (velocity times area) is constant, a change in one, would induce an opposite change in the other.

The *WATS League Table*, the histogram and the free-text responses highlight different aspects of the students' understanding and in so doing provide the intelligence in which teaching adaptations can be based. There is little sense, for instance, in spending too much time revisiting the subject of WATS 2 (Table 5-6). Here the teacher's effort would be best used to stretch the students beyond their demonstrable understanding. This is in contrast with the students' performance in WATS 9. In this situation the teacher's effort would be best used to revisit some of the fundamentals associated with the weekly task. There will also be limited benefit in revisiting anything in WATS 11 before responding to questions 4 and 5 (Figure 5-3). Finally, the free-text responses (as shown in Table 5-8) demonstrate that, while many students understand the concept of a conservation equation, most students are confused as to what is actually being conserved. Making evidenced-based teaching adaptations ensures part of the teaching sessions draw on the students' current conceptions and misconceptions and helps integrate the students' needs with those of the curriculum.

The consequence of this is teaching that is more student-centred and more learning oriented.

### 5.3.3 Stimulating teacher reflections

Related to the adaptation of teaching sessions and making the teaching sessions more student-centric is the notion that the students' demonstrable understanding raise important questions for the teachers. These are likely to include:

- Was one topic area more complex than the others?
- Was one topic area taught better?
- Were there more supporting resources for one topic area than another?
- Was one WATS task easier than the others and, if so, what might I change to make the challenges more appropriate and equitable?

The culmination of the above might be a question such as 'what is needed by me, the teacher, to reconcile any noted deficiencies?'

### 5.3.4 Evaluating the difficulty of the WATS

To help respond to the questions relating to the difficulty of the WATS, this work draws on the item-analysis highlighted in Chapter Two. In this case a calculation of the difficulty of each WATS is provided rather than a calculation of the difficulty of items in an MCQ assessment. While variations are offered in the calculations, they all focus on the number of students scoring above a grade compared to either i) the number of students submitting responses to that weeks task (Ds), or ii) the number of students who took the examination (De). Hence De and Ds are both ratios and are bounded between zero and one. A Ds or De value of zero represents a low level of difficulty whereas a Ds or De value of one represents a high level of difficulty. Equation 1 sets out an example calculation of De(66).

$$De(66) = 1 - \frac{n_{>65}}{n_{exam}} \quad \text{Equation 1}^{11}$$

The De variant makes more visible the fact that the students might not submit for an overly difficult task by excluding the students who did not complete the entire module. Hence De

---

<sup>11</sup>  $n_{exam}$  is the number of students that took the end of module examination

might better reflect the actual difficulty of the task. Although offered as a more appropriate indicator of the difficulty of the WATS, its calculation cannot be performed until the end of the module. Hence an interim review of the difficulty can be found by reviewing Ds.

The calculation of Ds or De reinforces the difference in the WATS mean scores and offers an alternative insight into the student performance and the ability of the WATS to differentiate between the students. At the 66% level the difficulty ( $De_{66}$ ) of WATS 2 was 0.12. This contrasts with the same calculation ( $De_{66}$ ) for WATS 9, which had a difficulty of 0.86.

Correlations of the examination score against individual WATS scores are given in Table 5-6. WATS 2, which has a low level of difficulty, has a correlation of 0.19 against the examination score. The correlation of WATS 9, which has a higher difficulty than WATS 2, against the examination score is 0.09. Although these data suggest that a more difficult task is likely to better support the examination, none of the correlations between the examination score and the individual WATS were high.

### 5.3.5 Worked Solution

In addition to the *WATS League Table*, which has been shown to provide valuable information for the teacher and the students, and hence has positive consequences for learning, the WATS programme provides additional support for learning in the form of a worked example. The worked example, provided immediately after the submission deadline, demonstrates an appropriate procedure to solve the weekly task and presents a commentary of the common mistakes.

Presently it is difficult to assess the students' active engagement with the worked solution. Its value might be judged by the number of student-unique accesses to this resource, see Table 5-9, and by student comments.

Table 5-9 Number of student unique accesses to the worked solutions (2006-07)\*

	WATS Number											
	1	2	3	4	5	6	7	8	9	10	11	12
Number of accesses	121 (70%)	122 (71%)	82 (48%)	90 (52%)	83 (48%)	81 (47%)	78 (45%)		55 (32%)		69 (40%)	49 (28%)
Ds(50)	0.10	0.16	0.15	0.36	0.04	0.20	0.04		0.18		0.41	0.13

\* Information was only available for 2006-07

WATS 8 and WATS 10 were not issued during 2006-07.

Apart from the first two weeks, where 70% and 71% accesses were observed, generally fewer than half the group accessed the worked solution from week three onwards. There is a

strong negative relationship ( $r = -0.72$ ) between the number of accesses to the league table and the week number, thus demonstrating a declining number of accesses as the semester progresses. This is disappointing since it can also be shown that there is a positive relationship between the difficulty of the task and week number; that is, as the semester progresses the WATS increase in difficulty (as measured by  $Ds_{50}$ ). The difficulty of the task did not appear to influence the students' motivation to access the worked solution ( $r=-0.12$ ). Further, in all weeks the number of student accesses to the worked solution was fewer than the number of accesses made to the *WATS League Table*.

From the student comments, it is apparent that differences exist in students' opinion of the worked solution. Less favourable comments relating to the worked solutions include,

*... for the worked solutions it would be handy if some of the calculations were precisely explained, some times it seemed as if numbers would appear from no where, with little or no explanation of how they were obtained (S23 2005-06).*

And,

*WATS is a very good way of getting feedback. However it could be improved, since the worked solutions aren't always clear enough for a full comprehension of the subject. (S141, 2004-05)*

*[I] would rather be shown how my figures would fit into the worked examples rather than somebody else's (S178, 2005-06)*

The three previous comments seem to be summarised by one student's writing when he suggests:

*The Worked Solutions were too hard to follow for some of the wats (S136, 2005-06)*

Even though some students noted issues about the clarity of the worked solution, such as where the numbers came from, the above comments contrast with other student comments which include:

*No doubt at all that the WATS got me through the exam. The solutions for the WATS were the main factor and made brilliant revision material. It even made some of the complicated stuff look relatively simple. Why is that? (DF, 2002-03)*

*It is an excellent method of ensuring that the topics are understood and if they are not, any problems can be solved using the worked solutions given after the deadline has passed. (S140, 2005-06)*

Other comments relating to the value of the worked solution, specifically in supporting the students' revision include:

*... Now it's time for revision and re-doing WATS questions will help along with the worked solutions (S52, 2004-05)*

*And;*

*its easy for me to revise through watts and their worked solutions (S78, 2004-05)*

Section 5.3 presented the opportunities the WATS approach to assessment brings to motivate learning, adapt teaching and stimulate teacher reflections. Central to this section are the *WATS League Table*, the *Worked Solution*, and the students' free-text responses to open questions. Apart from the few observations surrounding the clarity of the worked solution, which were not universally accepted, the feedback instruments also provide valuable consequences for learning. The students enjoyed the competition, they were drawn back to *StudyNet* and they were exposed to evidenced-based teaching adaptations arising from their demonstrable understanding of the topics.

The following section explores the impact of the assessment programme on student performance.

## 5.4 The impact of the assessment programme on student performance

This section commences with the students' performance on the WATS tasks and progresses to describe the students' examination performance. Relationships between the examination and the WATS scores conclude the section.

### 5.4.1 Performance on the WATS

A total of 11 WATS were issued to the students; i.e. one per week over the semester. The students' individual and comparative performance can be seen in the *WATS League Table*. A summary of the descriptive statistics for each of the cohorts is given in Table 5-5.



Table 5.5 Cohort performance on the WATS

	2002-03	2003-04	2004-05	2005-06	All Years
Mean %	56.4	63.5	59.5	66.9	61.9
25th Percentile	46.0	53.1	47.0	56.6	50.3
50th Percentile	61.6	66.8	61.8	71.2	65.8
75th Percentile	70.8	77.6	75.3	89.3	77.6
Standard Deviation	22.4	19.4	21.1	19.6	21.0
> 34%*	107 (84%)	123 (93%)	144 (88%)	161 (94%)	535 (90%)
n (exam)**	128	133	163	172	596

\* 35% is the default pass mark, hence >34% indicates the number of students passing the WATS

\*\* n (exam) represents the number of students in the module that took the module examination.

In all cohorts a high proportion of students' scores (>80%) were above the pass mark (35%). The overall WATS mean scores were also above the pass mark.

Frequency plots of the cohorts' performance are shown in Figure 5-4. To account for the different cohort sizes; n=128 (2002-03), n=133 (2003-04), n=163 (2004-05) and n=172 (2005-06); the results in Figure 5-4 represent the relative frequency distributions. The shape of the frequency distribution is similar across the cohorts; that is, all cohort profiles are negatively skewed with the peak class occurring between scores of 60-80%. The peak in the highest class also attracts around 25% of the cohort.

Figure 5-4 Relative frequency distributions of the students WATS scores

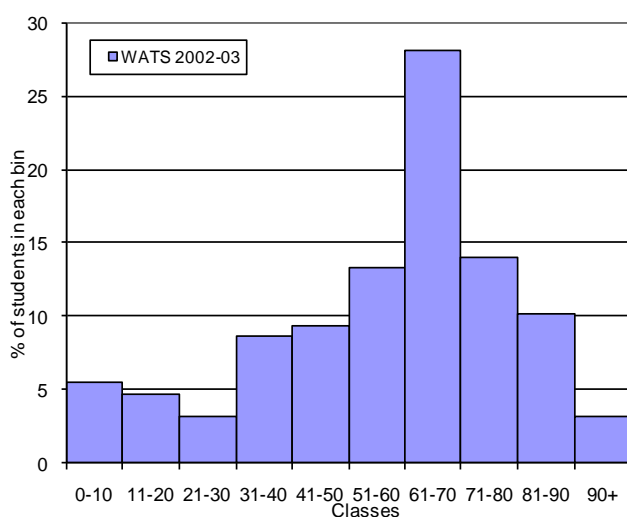

a) 2002-03

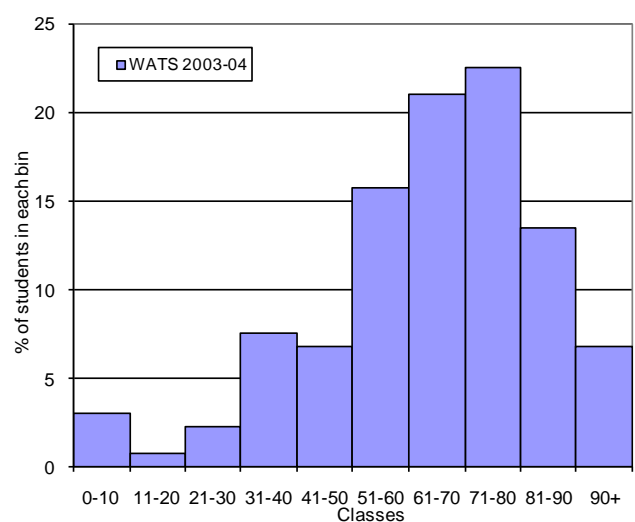

b) 2003-04

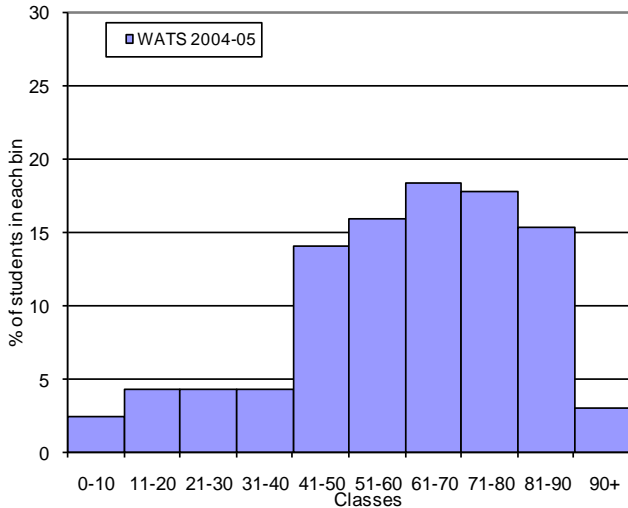

d) 2004-05

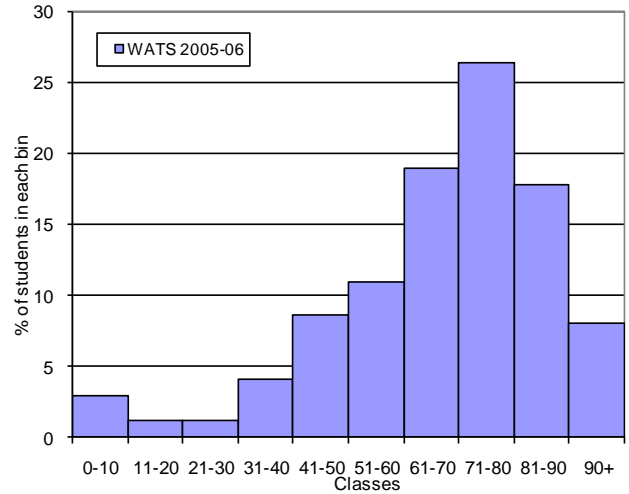

d) 2005-06

The student performance in the WATS is not the only measure of its success. Performance in the examination will also indicate the validity of the assessment programme's ability to enhance the students' learning and understanding of the subject. The following section, therefore, presents the students' examination scores.

#### 5.4.2 Performance on the examination

The use of examination scores to judge student performance is particularly pertinent because it was the poor examination performance in 2001-02 that stimulated this research activity and the subsequent development of the assessment programme.

In addition to presenting post-WATS cohort examination comparisons, comparisons are also made to the pre-WATS cohort (2001-02) examination score. The pre-WATS cohort can be viewed as a useful benchmark with which to compare any improvement in performance. By definition the pre-WATS cohort were not exposed to the WATS approach to assessment. During the period of investigation, 2001-02 to 2005-2006 inclusive, the module descriptors and the main teaching practices remained reasonably constant. The significant change, as described in Chapter Two, was the replacement of the one-off in-module phase test, used during the 2001-02 session, with the WATS approach to assessment.

Table 5-10 Examination performance, without and with WATS

	<i>Without WATS</i>	<i>With WATS</i>			
	<i>2001-02</i>	<i>2002-03</i>	<i>2003-04</i>	<i>2004-05</i>	<i>2005-06</i>
<i>Mean %</i>	39.4	47.1	42.2	51.6	33.5
<i>SD</i>	24.1	23.7	21.3	22.6	23.2
<i>&gt; 34%*</i>	63 (50%)	88 (69%)	83 (62%)	125 (77%)	75 (44%)
<i>P10</i>	10.4	15.1	13.0	20.0	7.0
<i>P20</i>	17.0	25.0	20.4	30.0	11.2
<i>P25</i>	20.0	29.0	27.0	36.5	14.0
<i>P30</i>	25.0	33.1	31.6	40.0	16.3
<i>P40</i>	30.6	40.0	39.8	48.0	22.4
<i>P50</i>	35.0	48.0	43.0	55.0	27.5
<i>P60</i>	41.0	53.0	48.0	61.0	37.6
<i>P70</i>	50.8	60.7	52.4	67.0	44.0
<i>P75</i>	57.0	65.0	56.0	69.0	52.0
<i>P80</i>	61.0	70.0	60.2	71.0	53.0
<i>P90</i>	76.6	81.0	67.0	78.0	69.9
<i>n (exam)</i>	125	128	133	163	172

\* 35% is considered the typical pass-fail boundary, hence >34% is considered a minimum pass.

Exploration of the examination data presented in Table 5-10 will show that improvements arose in most of the examination performance indicators. The mean examination score improved from the pre-WATS value of ~39% (2001-02) to ~47% (2002-03), ~42% (2003-04) and 52% (2004-05). The median scores (P50) for the years 2002-03, 2003-04 and 2004-05 also improved. Significantly, in the years 2002-03, 2003-04 and 2004-05 the median is above the pass mark. This was not the case for the pre-WATS cohort. In the pre-WATS year the median was 35%. Related to the increase in the cohort median, is the increased number of students that scored over 34% in the exam, the typical pass boundary. By definition this figure also rose, and increased from 63 (50%) 2001-02 to 88 (69%) 2002-03, 83 (62%) 2003-04 and 125 (77%) 2004-05 after the WATS were introduced.

Additional analysis of the examination results shows that for all years, excluding 2005-06, there is an increase in student performance in the majority of percentiles. The largest gain, the difference between the post-WATS percentiles and the pre-WATS percentiles, occurs around the middle percentiles, 50th in 2002-03 and 2004-05 and the 40th in 2003-04. The examination results for 2005-06 are not consistent with the other cohorts. There is a decline in student examination performance in the mean and number of students scoring over 34%. A discussion of these results and the possible causes is given in Chapter Six.

Frequency distributions of the examination grades are shown in Figure 5-5.

Figure 5-5 Relative frequency distributions of the students' exam scores

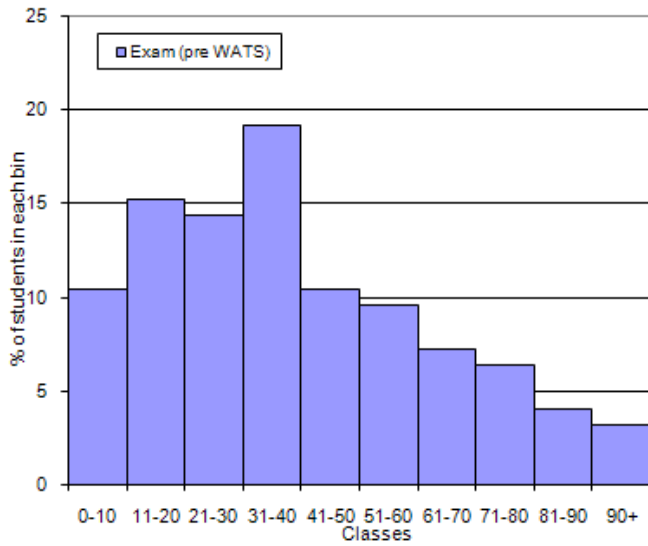

a) 2001-02 (pre-WATS)

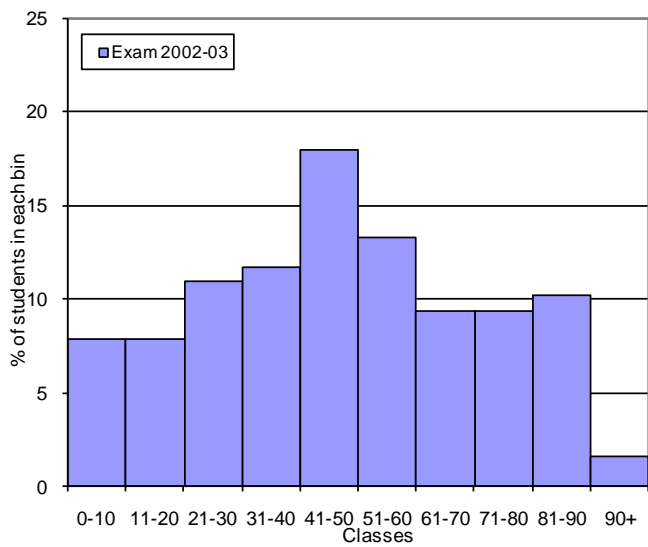

b) 2002-03

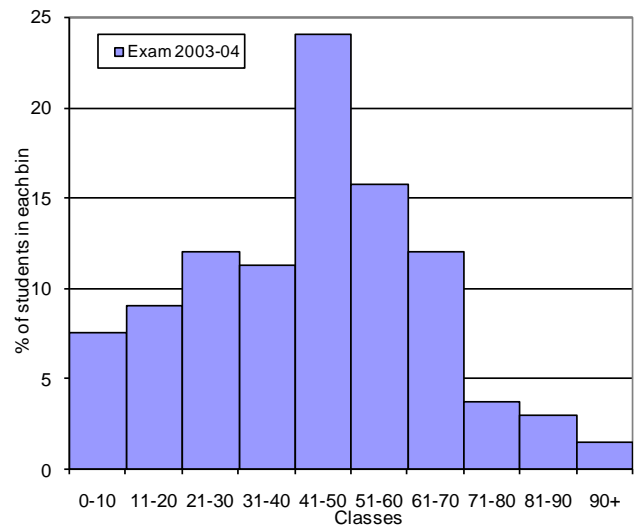

c) 2003-04

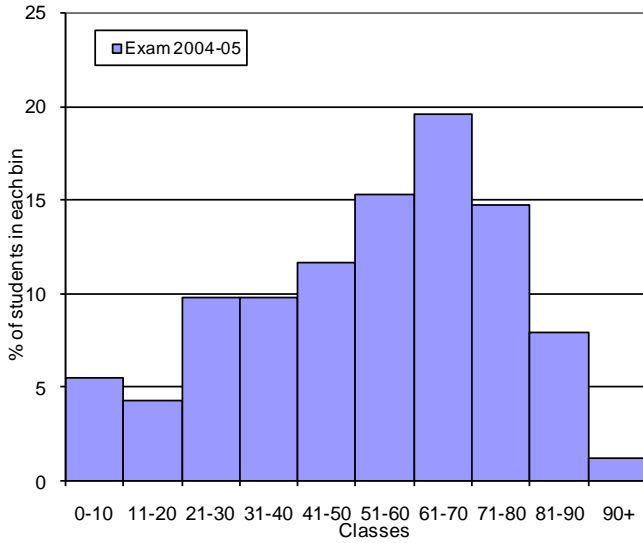

d) 2004-05

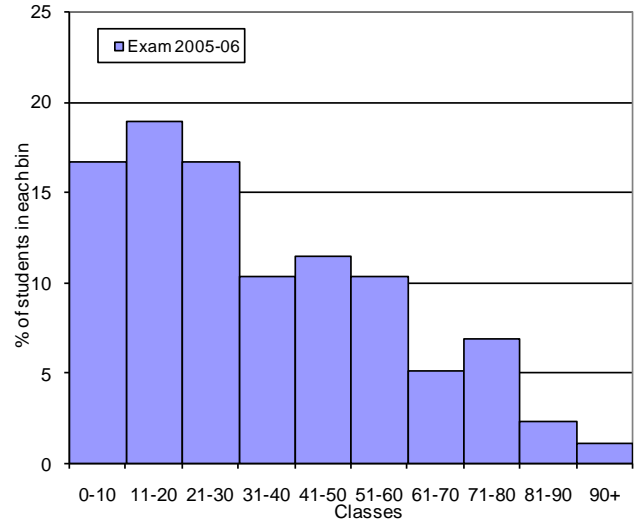

e) 2005-06

Although there is less of an observable pattern in the students' examination grades there is a shift from a positive skew, pre-WATS skew = 0.51, towards a normal distribution or negative skew (Figure 5-5). The calculated skews of the distributions are 0.02 (2002-03), 0.11 (2003-04), -0.45 (2004-05). The exception to a normal or negative skew is the 2005-06 cohort. The calculated skew for 2005-06 is 0.61. The implications of a positive skew are that the number of students doing less well in the exam increases.

The results presented in this section start to indicate the benefit of the WATS approach to assessment. There is an increase in the examination mean and median scores, as well as the number of students scoring more than 34% in the examination, the typical pass/fail boundary. The significance of the exam grade increase is presented in the following section.

#### 5.4.3 Significance of the exam grade increase

Independent t-tests were performed to examine the hypothesis that improvements in examination performance arose as a consequence of the assessment programme and not by chance alone. The hypotheses for the tests are;

The WATS approach to assessment created a better performance in the examination than occurred with the 2001-02 pre-WATS cohort.

A consequence of the hypothesis leads to the mutually exclusive null ( $H_0$ ) and directional alternative ( $H_1$ ) hypotheses;

$H_0$ : ExamPostWATS  $\leq$  ExamPreWATS

$H_1$ : ExamPostWATS  $>$  ExamPreWATS

The null hypothesis will be rejected at the 5% level that is if  $p \leq \alpha \leq 0.05$ . Results from the t-tests for each post-WATS cohort against the 2001-02 pre-WATS cohort is given in Table 5-11.

Table 5-11 t-test results comparing pre and post WATS cohort examination scores

	2002-03	2003-04	2004-05
<i>p</i>	0.006	0.159	000
<i>Interpretation</i>	Reject $H_0$	Fail to reject $H_0$	Reject $H_0$

In both 2002-03 and 2004-05 the data suggests the null hypothesis ( $H_0$ ) can be rejected. That is, there is less than a 5% chance that the improvement in the examination grades occurred by chance alone. Accordingly the improvement in the mean examination scores for 2002-03 and 2004-05 are statistically significant.

Although the cohort mean increased from 38.7% (2001-02) to 42.2% in 2003-04, that increase cannot be offered as being statistically significant. Since  $p > \alpha > 0.05$  there is insufficient evidence, for this cohort, to reject the null hypothesis.

#### 5.4.4 WATS and examination grade correlations

Sections 5.4.1 and 5.4.2 separately presented the students' scores on the WATS and the examination performance. Individual students' WATS scores against their examination scores are presented in Figure 5-6 a-e. Individual students are shown as separate entries on the graphs and are denoted by unfilled circles. The solid line represents the relationship *WATS score = examination score*. Hence any student obtaining a higher score in the WATS than the examination will be positioned below the solid line. Likewise, any student obtaining a higher score in the examination than the WATS will be positioned above the solid line. The dashed line represents the line of best fit between the WATS and examination scores.

Figure 5-6 Plots of the WATS scores against the Examination scores

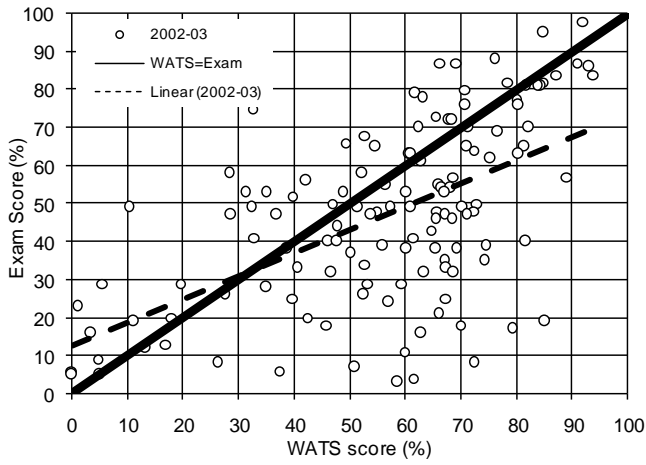

a) 2002-03 (n=128)

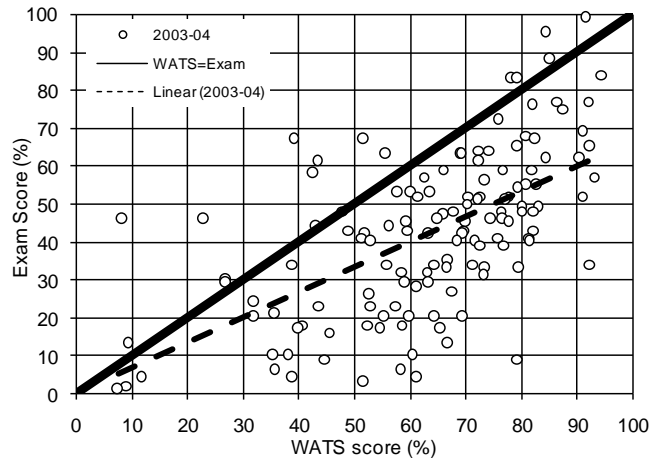

b) 2003-04 (n=133)

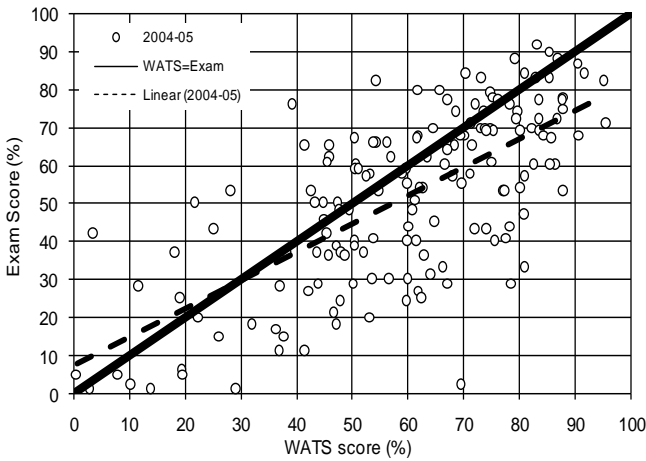

c) 2004-05 (n=163)

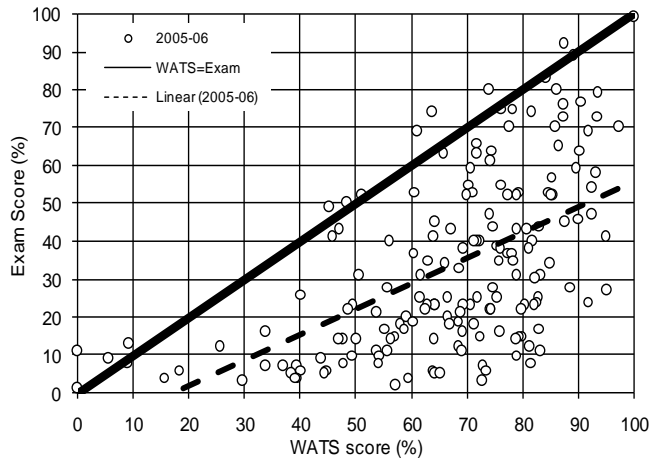

d) 2005-06 (n=172)

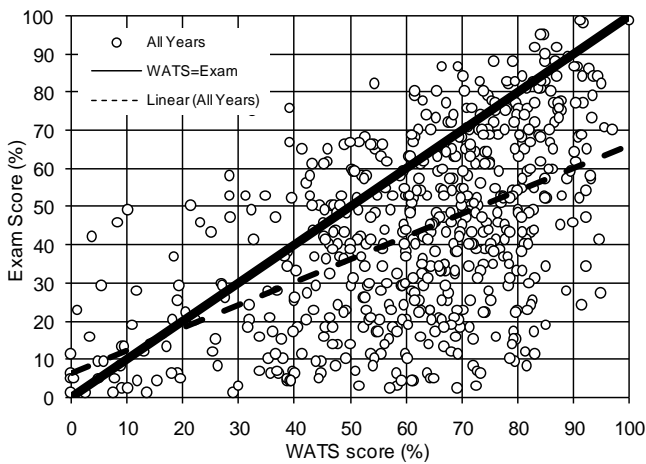

e) All years (n=596)

In each year of study there were more students scoring higher marks in the WATS than the examination. A summary of the data is presented in Table 5-12.

Table 5-12 Numbers of students scoring higher or equal to their WATS score in the examination

	2002-03	2003-04	2004-05	2005-06	All years
Exam >= WATS	43 (33.6%)	17 (12.8%)	51 (31.3%)	12 (7%)	123 (20.6%)
n (exams)	128	133	163	172	596

Although it is of interest to note the students' comparative performance on the WATS and the examination, there is no reason to expect the students to gain an identical score on separate and different assessment methods. What is more important is an exploration of the hypothesis that a high WATS score implies a better understanding of the subject and hence will lead to a high score in the examination. This implies a positive correlation between the students' examination and WATS score. These correlations are indicated in Figure 5-6a-e by the superimposed linear line of best fit. The results of regression analysis between the examination and WATS scores are presented in Table 5-13.

Table 5-13 Correlating the examination and WATS scores

	2002-03	2003-04	2004-05	2005-06	all years
Pearsons r	0.580	0.605	0.697	0.568	0.348
p	0.00	0.00	0.00	0.00	0.00
R <sup>2</sup>	0.34	0.366	0.486	0.322	0.121
Alpha	12.46	0.034	7.254	-11.447	6.377
Beta	0.61	0.664	0.746	0.671	0.597

In all the years of study there exists a positive relationship between the examination and WATS scores and the values of Beta, ( $\beta < 1.0$ ) indicate the students did better in the WATS than the examination. The analysis also indicates the relationships are statistically significant at the 5% confidence level ( $p < 0.05$ ).



#### 5.4.5 Student voice; WATS supporting the exam

The positive relationship between the WATS and the examination was also noted by the students themselves. Following the examination in 2002-03, one student wrote on the module discussion forum,

*Having just completed the Fluids & Thermodynamics exam this morning, and hopefully passing it (just) I have [to] agree with the WATS. I really felt they help me during the year and not only gave me a good mark 4 my coursework but were a useful revision tool 4 the exam. (DF 02-03)*

This was followed by another post,

*No doubt at all that the WATS got me through the exam. The solutions for the WATS were the main factor and made brilliant revision material. (DF 02-03)*

Other comments from the students before taking the examination offer their conjecture that the WATS will be a benefit to their studies and ultimately their examination performance. Such comments are typified by,

*It forces you to revise every week. Surely the exam performance will be improved (S64, 2003-04).*

*Great idea to keep students constantly revising and up to date on their knowledge of the whole year.... incredibly useful tool for learning and exam preparation. Would like to see this in more subjects as i feel they don't allow for constant practice and revision (S174, 2004-04)*

Section 5.2 presented the students' performance on the WATS and the module examination. In three of the four years, similar patterns of student performance were observed. There was an increase in mean examination scores; the largest increase in examination performance occurs in the 40-50th percentiles; and there exists a positive correlation between the students' WATS and examination scores. These findings are also supported by the students' statements with many acknowledging the benefit of the assessment programme to their studies and a conjecture that the WATS approach to assessment will benefit their examination performance.

Sections 5.1 - 5.4 inclusive reported on the impact of the assessment programme on the students' behaviours and performance. The results included the students' examination and WATS performance, their engagement with the discussion forum and also their access of

the WATS resources. In some instances that data was supplemented with observations made by the students themselves. The following section supplements these findings and places greater emphasis on the voice of the student.

## 5.5 The student view of the assessment programme

The student view was collected from a 13 item WATS specific questionnaire (see Appendix E) and also from the students' free-text posts.

### 5.5.1 Questionnaire responses

Student responses to the 13 items of the questionnaire are provided in Table 5-14. There is close agreement between what each cohort valued about the assessment programme and what they did not. Specifically, the students indicate they think *the WATS will help them in the exam* (q6, ranked 1st out of 13) and *they like getting a mark* for their efforts (q10, ranked 4th out of 13). Further, although ranked at 8th out of 13, the students are still in agreement that *overall the WATS are excellent* (q13). Given these points, many of the students indicated they would not *do the WATS unless they counted towards the module grade* (q7, ranked 10th out of 13). This point is perhaps supported by the students' negative response to the statement *I really like doing the WATS* (q9 ranked 13th).

In support of one of the themes behind the development, a learning orientation, the students *like the use of student unique data* (q3 2/13) and also respond positively to the statement *you only do only do well in the WATS if you understand the subject* (q1 6/13). This is encouraging since the assessment programme was, after all, trying to stimulate learning and understanding.

Table 5-14 Question scores for the WATS specific questionnaire

<i>Question</i>	<i>Question Fragment</i>	<i>2003-04</i>	<i>2004-05</i>	<i>2005-06</i>	<i>all years</i>
1	Do well if understand.	2.32 (6)	2.19 (6)	2.49 (9)	2.34 (6)
2	Trust data collection and marking	2.62 (10)	2.79 (11)	2.95 (12)	2.79 (11)
3	Student unique data is excellent	2.15 (1)	2.03 (3)	1.87 (1)	2.01 (2)
4	Weekly is excellent	2.50 (9)	2.52 (10)	2.41 (7)	2.48 (9)
5	Other subjects could benefit	2.45 (8)	2.06 (4)	2.19 (5)	2.23 (5)
6	WATS help in exam	2.24 (2)	1.70 (1)	1.98 (2)	1.97 (1)
7	Still do if did not count	2.97 (12)	2.46 (9)	2.87 (11)	2.76 (10)
8	League table excellent	2.31 (4)	1.87 (2)	2.07 (3)	2.07 (3)
9	Really like doing	3.28 (13)	2.95 (12)	3.12 (13)	3.10 (13)
10	Like getting a mark	2.26 (3)	2.10 (5)	2.16 (4)	2.17 (4)
11	WATS do not hinder other studies	2.94 (11)	2.96 (13)	2.85 (10)	2.92 (12)
12	No lateness excellent idea	2.31 (5)	2.40 (7)	2.40 (6)	2.37 (7)
13	Overall WATS excellent	2.41 (7)	2.42 (8)	2.48 (8)	2.44 (8)

\* Bracketed values indicate the ranking of the question item.

In addition to the closed questions of the structured questionnaires, the student view has been collected from an open question relating to the WATS programme and also by recording data arising from less formal feedback mechanisms such as e-mail correspondence and contributions to the discussion forum. The following section presents the students' responses to the open question.

### 5.5.2 Free-text responses

Across the three cohorts (2002-03 to 2005-06), a total of 292 short responses have been received to the question, 'now you have completed the WATS what comments do you have regarding this approach to teaching, learning and assessment?'

86 responses were collected from 2002-03, 93 responses from 2003-04 and 113 responses from 2005-06. The students' responses were collected via the *WATS Data Gatherer* as they submitted their response to WATS11. A summary of the descriptive data of the free-text responses is given in Table 5-15.

Table 5-15 Descriptive data of the students' free-text responses

	2003-04	2004-05	2005-06
<i>No of responses</i>	86	93	113
<i>Max number of words in response</i>	162	166	101
<i>Minimum number of words in response</i>	1	2	1
<i>Average number of words in response</i>	32	38	24
<i>Total number of words</i>	2760	3565	2700
<i>No of unique words</i>	641	730	646

### 5.5.3 Coding the free-text responses against the research questions

An overview of the coding results is presented in Table 5-16. Analysis of the free-text responses shows 40% of the students noting the impact of the assessment programme on their *study behaviours*. Around 20% of the students' comments were coded against *teaching and learning oriented support* whereas only 5% of the students noted the possible impact of the WATS approach to assessment on their *performance*.

Table 5-16 Coding of student responses (2003-04 – 2005-06)

<i>Performance Group (PG)</i>	<i>Number in PG</i>	<i>Study Behaviours</i>		<i>Teaching &amp; Learning</i>		<i>Performance</i>	
		<i>n</i>	<i>%</i>	<i>n</i>	<i>%</i>	<i>n</i>	<i>%</i>
1	142	65	45.8	34	23.9	9	6.3
2	131	46	35.1	24	18.3	3	2.3
3	19	4	21.1	5	26.3	1	5.3
<i>Total</i>	292	115	39.4	63	21.6	13	4.5

There is seemingly a positive relationship between the Performance Group and the number of responses relating to *study behaviours*. This suggests that the students who performed better also benefited from the good study behaviours that the WATS approach to assessment encouraged. The trend is consistent across all cohorts. No discernable relationship is evident between the Performance Group and the responses relating to Teaching and Learning support or Performance. Of the 115 comments related to study behaviours, 48 were from students who noted the positive effect of being *forced or made to learn*.

The responses add a supplementary commentary to the closed questions of the questionnaire and provide useful data in which to triangulate the findings. Outside the research questions, five additional themes arise from the students' responses. These are:

### 5.5.3.1 The assessment programme creates a learning orientation

54 of the comments were coded as being useful for learning. The comments highlighted various aspects of learning including how the assessment programme encourages engagement, supports the lectures, stimulates thinking and appropriately distributes the students' effort across the semester.

Example responses include;

*it was a good idea it made you read through the notes more often than you usually would. (S42, 2003-04)*

*i believe that this method has been very useful, because you have to spend time each week learning the work. (S87, 2003-04)*

*i believe wats are good exercise for this module and it covers all the bullets points of lecture and tutorial, and it should be continue for coming students. and its easy for me to revise through wats and their worked solutions. (S18, 2004-05)*

....

*it's great for actually making students understand the subject through practice. you can't just copy because every answer requires some level of thinking (S63, 2004-05)*

*gave me a good reason to stop and make time to think and study for the problems given to us via wats. a good way of learning. (S158, 2005-06)*

### 5.5.3.2 The assessment programme helps to develop self awareness

Linked to the learning oriented theme is the suggestion that the assessment programme created in the students a self-awareness of their learning; that is, the assessment programme helped them learn more and showed them where they had gaps in their knowledge. Example responses include,

*i think wats helped me learn the course and highlighted the areas i needed to do more work on (S99, 2003-04)*

*... it felt good to know how you were doing week by week, especially when you were doing well. being assessed throughout a course instead of all at the end is*

*a much better way to see how well someone is doing. that especially applies to me. (S54, 2003-05)*

*has been a different experience but the wats system has been enlightening and helped me greatly in my studies (S22, 2005-06)*

### 5.5.3.3 There are examples of a goal-oriented approach to learning

Although the students note the positive consequences of engagement (see Sections 5.5.3.1-5.5.3.2), this theme arises in the responses that are focused on examination preparation rather than learning, and those that raise concerns about the time, effort and the associated grade structure. 23 comments were coded as suggesting a goal orientation.

Example responses include

*I'm sorry but i didn't like this approach, mostly because i think it has a very low influence on the final mark compared to the effort in time it requires. (S40, 2003-04)*

*good way to revise the different topics, but i think that more marks should be awarded for the amount of time spent doing the work. (S164, 2004-05)  
considering how much time we spend each week on wats, and now knowing how much it counts towards the module, it seems as if it isn't worth that much.(S16, 2005-06)*

### 5.5.3.4 Some students perceive the existence of an unfair marking system

This theme arises due to some of the students questioning the marking system, being concerned about coupled-questions and indicating they would prefer non-computerised marking. 49 students raised issues about the marking.

Example responses include

*i feel the wats was a good idea and helped learn while going along. sometimes however when the answer i give is wrong, the method may be correct but no marks, bit de-motivating. if possible de-coupling i think could be used more often. (S167, 2004-05)*

*i feel that the principle behind the idea (i.e. having an assessed sheet every week, with individual data) is a good idea, however i do not feel comfortable with a computer system marking my results. i feel it would be far better if the lecturers/tutors should sit down and mark it through themselves. i know this would mean a lot of work for them to do, but if they're prepared to set the work, then they should be prepared to mark it (S24, 2005-06)*

*i like it, but i think the results should be checked by a person.(S199, 2005-06)*

### 5.5.3.5 Impact on other modules

18 of the students' comments were about the use of the WATS and their potential negative impact on the students' other modules. Students were seemingly concerned that the assessment programme was demanding too much of their time and not allowing them to distribute their effort to other modules. Quotes relating to this theme include,

*i have found the wats to be very time consuming, especially this week, when we had so many other assignments to complete as well as having to revise. i feel other modules plus revision have been neglected so i could complete the wats each week. (S169, 2005-06)*

*hard work but worth it i think although it did tend to take concentration away from other subjects (S84, 2005-06)*

*i have learnt a great deal more through doing wats than i could have done using other methods of revision. however as the weeks have progressed the amount of time spent on wats has greatly increased so much so that it has detracted from other work and revision (S159, 2005-06)*

Such comments were not widely accepted. Seven students specifically commented that they wanted to see the WATS used on other modules, example quotes include,

*according to me it is an excellent way of teaching both for teachers as well as students. hope it should be introduced in other subjects as well. well done -- that's what i will say at the end. (S131, 2003-04)*

*i think we need this WATS for all of the subject (S5, 2003-04)*

*great idea to keep students constantly revising and up to date on their knowledge of the whole year.... incredibly useful tool for learning and exam preparation. would like to see this in more subjects as i feel they don't allow for constant practice and revision (S174, 2004-05)*

This section identified the results gained from the student responses to the questionnaire and the free-text question. There is close agreement across the cohorts in terms of the assessment features that are valued as well as those that were not. Analysis of the students' free-text responses led to the identification of five additional themes:

- The assessment programme creates a learning orientation
- The assessment programme helps to develop self awareness
- Some students have a goal (strategic) approach to learning
- Some students perceive the existence of an unfair marking system
- There is a perception that the assessment programme impacts on other modules

#### 5.5.4 Interviews

The student examination performance in 2005-06 countered the trend of improved examination performance since the WATS were introduced in 2002-03. To help understand what led to the disappointing results an additional study was undertaken.

Students from the 2005-06 cohort were invited to participate in semi-structured, one-to-one interviews. The interviews were conducted by a research assistant not connected with the module and not known to the student. The interview included questions about the WATS. Ten students participated in the interviews. The interviews typically lasted around 1.5 hours, were recorded and transcribed.

The interview participants generally understood the rationale for the WATS and their potential benefits for learning. As such the interview participants did not appear to offer any new insights than was previously gained. An interesting insight as to why the 2005-06 cohort had possibly not done so well came from one of the interview participants (Participant 7). After talking about the module, the resources and the lectures he spoke about WATS. The following conversation took place,



*[P7] With some of them [WATS] we had no idea, we just couldn't do it, and we found a web site<sup>12</sup> on Google, with all the answers to WATS. And the funny thing was it was all done Mark Russell and it said if you have any problems e-mail me at [m.b.russell@herts.ac.uk](mailto:m.b.russell@herts.ac.uk). And then after a certain point we just starting using that [the worked solutions] to do all our WATS work*

*[Interviewer] What point was that, can you remember?*

*[P7] I think about WATS 5*

*[Interviewer] And then how did you [find them], so did someone do a search on Google*

*[P7] I don't know how someone found out but they were just typing WATS and this web site came up and it had all the worked solutions*

*[Interviewer] So then that was what you used to do, would you say all of them after that point?*

*[P7] Yeah, because, you know after the point. The only reason we used that site was because it was really hard to begin with and we just couldn't do some of those questions. So after that point we just used the site [web site with worked solutions].*

*[Interviewer] So you don't know who found it? Was it someone could have simply types WATS into Google.*

*[P7] maybe yeah, we were just doing work on a group table and someone told us we don't know who actually found it*

*[Interviewer] Did word quickly spread about that [the solutions] ?*

---

<sup>12</sup> The WATS approach to assessment received mini-project funding from the Higher Education Academy, Engineering Subject Centre (HEA EngSC). The WATS and associated worked solution were stored on the HEA EngSC web site.

*[P7] I think it did yeah, cos I told a few people and they would have told others.  
After I would look at the q and see if I could understand it.*

*[Interviewer] After you found this web site were you using the answers and putting them into the WATS, is that how you were working on them [the WATS] after that?*

*[P7] I'd look at the question and see if I could understand it, I wouldn't copy the WATS. I'd look at the worked solution and see if I could make sense of it.*

*[Interviewer] Before you discovered this web site how did you work on the WATS*

*[P7] I did it by myself*

*[Interviewer] Can you describe what sort of things you did?*

*[P7] I did get help for it, because I knew someone that had done this course earlier on.. My brother he had done [previously] aerospace*

*[Interviewer] Would you go to him only if you got stuck or did you go to him for all of them and say can you give me a hand?*

*[P7] Only if I got stuck, yeah,*

The conversation then progresses to other aspects of the WATS and the module.

The above interview transcript suggests that many of the 2005-06 students would have been alert to the existence of the WATS worked solutions prior to engaging in the weekly activity. The implications of students using the worked solution are discussed in Section 6.3.8.

## 5.6 Close of Chapter Five

Results arising from the implementation of the assessment programme have been presented. These results included the ability to monitor and support the students' wellbeing as they engaged in their studies (Section 5.1); the number of students engaging in the aligned, weekly tasks (Section 5.2); the opportunities the assessment provides for student-teacher dialogue and reflection (Section 5.3), and the students' performance on the weekly tasks and the examination (Section 5.4). These evidences of impact are supplemented by the student view, which includes responses to closed questionnaire items on specific features of the assessment programme and differing observations made in response to an open question (Section 5.5).

This chapter provides numerous forms of evidence to suggest the assessment programme has made a positive influence on the students' learning. High proportions of the students are engaging in the activity. This is evidenced in the weekly submission profile and also by observing the student contributions to the discussion forum. The high level of contributions to discussion forum was not evident in other modules.

The following chapter discusses the results and also looks at the generalisations that can be drawn from the research given its specificity to the local context.

## 6 Discussion

Chapter Five presented results arising from the implementation of the WATS approach to assessment. This chapter takes forward the preliminary discussion and discusses the results in relation to the literature, the student voice and the design themes underpinning the development of the assessment programme. In doing so this chapter specifically responds to the thesis that the assessment programme enhances student support, teaching and ultimately student learning.

### 6.1 Enhancing student support

Arguably the students' wellbeing is a foundation on which their learning can be constructed. There is little chance of the students being 'available' to learn if they are experiencing distracting demands. This suggestion is analogous to Maslow's Hierarchy of Needs (Mullins, 2007), which dictates that individuals cannot be motivated by their higher order needs until their lower order needs, which also include health and wellbeing, are satisfied.

A computer based system specifically developed to establish students at risk is described by Tait & Entwistle (1996). The system is based on the Approaches to Studying Inventory (ASI) and identifies at risk students through their inappropriate study patterns. The motivation for the computer based development arose due to concern over failure rates and the suggestion that *"for most departments, the task of diagnosing possible sources of difficulty, where first year classes are large, is beyond the staffing resources available"* (ibid p. 97). Primarily established to support student learning, the WATS approach to assessment established additional opportunities to identify the incidence of distracting difficulties faced by the students as they engaged with their studies. Although not as sophisticated as the bespoke student support software developed by Tait & Entwistle (the WATS approach serves a different primary purpose), the WATS approach to assessment still provides useful indicators of student difficulty. Chapter Five, for example, presented examples of non-submitting students noting issues of health and unexpected family demands. Such insights have been valuable in offering the students appropriate pastoral support and guidance. These insights appear to have arisen through the regular contact between the teacher and the students that was stimulated by the automated *did not submit* e-mail. The students were clearly noting the existence of the e-mail and in many instances responded by highlighting the difficulties that hindered their engagement or, where limited justification was forthcoming, offered their

apologies for non-engagement. Many students also offered a commitment to re-engage with the assessment programme.

*I apologise for not submitting the last two WATS papers, I have had some family issues that have required my full attention these last few weeks. These issues have now been resolved, i can assure you that i will not fail to hand in the following WATS papers. Apologies, (S134, 2006-07)*

*Believe it or not i'm kicking myself now because i did actually do the work ready to submit. In fact i even did it early (a first for me) but this must have given a false sense of security because i simply forgot to hand it in. Just thought i'd let u know and it definitely won't happen again. Regards (S84, 2004-05)*

*I am sincerely sorry for not handing in wats 7 and that my performance in wats 6 was inadequate. I had to leave the country in a rush on the 11th. I handed in wats 6 or what I had done of it, just before I finished moving all my belongings from halls. I have not even looked at anything and fear that I am falling behind. Fortunately my flat mate is amazing and shall probably have the notes for me. Kind regards (S25, 2004-05)*

The first student comment suggests the issues are now resolved. The second provided an opportunity to encourage the student to establish an appropriate study pattern that included time for engagement in the activity and submission of work whereas the third stimulated a dialogue regarding contingency planning while the student's difficulties remained.

By design, the assessment programme incorporated feedback mechanisms to inform both participating and non-participating students that the teaching team were aware of their commitment, or other, to that week's task. Specifically with the non-participating students the intention was to motivate them to re-engage and submit a response to the following week's task. A review of the *WATS League Table* (Figure 3-19) suggests this design feature appeared to have the desired effect. There are only a few repeated periods of non-submission from some of the students. The majority of the disengaged students displayed a submission profile that included submissions and a limited number of non-submissions. In these examples the submissions, which typically reappeared after a week or two of non-submission, are likely to have been encouraged by the *did not submit* e-mail.

The *did not submit* e-mail provided an additional opportunity for contact between the students and the teaching team, a feature of good practice in undergraduate education (Chickering & Gamson, 1987). The additional contact between teachers and students was not created, nor was as evident, with the phase test used in 2001-02. Prior to the development of the assessment programme, the teaching team were not as aware of the difficulties the students were facing and hence had limited opportunity to offer pastoral support. This contrast is important since universities are likely to see a continued growth in both student numbers and student diversity without an attendant increase in teacher-student contact time. In such situations the continued use of one-off type assessments is likely to be increasingly problematic and the disconnection between students and teachers will grow. Gaining information about the students and their wellbeing will subsequently reduce, disengaged students are likely to go unchallenged and students' pastoral needs will go unnoticed. The culmination of these factors is likely to impact on student failure and ultimately retention.

The introductory chapters discussed the challenges faced by students as they entered HE. The transition to HE is not easy and attrition rates are repeatedly reported as being high in the first year (OConnell & OCinneide, 2005; Thomas, 2008). Notable contributory factors include academic practices and curricula, formal and informal interaction with peers (Thomas, Quinn, Slack, & Cassy, 2002), time management, moving from a structured to an autonomous learning environment, a lack of feedback to inform students of their progress (Sevim, 2005) and a difficulty for teachers to get to know their students as class sizes grow (Rowntree, 1977). The WATS approach to assessment, developed in this research, responds to many of these factors. It helps to provide a structure and routine to the students' study time, while also offering some choice as to when the work is undertaken. It provides opportunity for prompt feedback, allows the students to see and monitor their own progress, provides a focus for the students to interact with each other and allows teachers to gain an insight into the individual engagement and performance profiles of large class sizes. These features may be significant in helping combat high failure and attrition rates.

Against the backdrop of increasing student numbers and reduced teacher-student contact time, this research has shown how the use of regular assessments on this module can stimulate student engagement and create performance data. This generates opportunities for the students to be re-engaged, better supported and, as a consequence, progress successfully through the module.

In addition to the pastoral support, the assessment programme provides information in which the students' learning oriented support can be enhanced.

## 6.2 Enhancing teaching

The literature provides numerous references relating to the impact of assessment on student learning. Chapter Two, for example, noted that *“assessment is the senior partner in learning and teaching; Get it wrong and the rest collapses”* (Biggs, 2003, p. 165) and *“the methods we use to assess students are one of the most critical of all influences on their learning”* (Ramsden, 1994, p. 67). Assessment stimulates student activity and establishes an opportunity to provide students with feedback on their activity. Good assessment is an essential component of students' learning environments (Bransford et al., 2000). Good assessments challenge students, are aligned with the learning outcomes, and provide useful information on the students' current conceptions. Knowing our students is not only important in terms of helping to inform pastoral care and guidance needs, but also enables us to note any student (mis)conceptions associated with the learning. The significance of students' misconceptions to support learning is offered by Biggs (2003, p. 142); *“admitting error leads to better understanding in the future”* and *“in the course of knowledge construction students inevitably create misconceptions, which need to be corrected: but first you have to find out what they are”* (ibid p. 77).

Angelo & Cross (1993) introduce fifty so-called Classroom Assessment Techniques (CAT's). These techniques range in complexity and the time they take to administer. They all, however, centre on eliciting students' conceptions and misconceptions. By definition the CAT's are generally undertaken in class and hence there is an associated time deficit from the teaching session as the students engage in the CAT activity. The WATS approach to assessment mirrors much of the intent of the CAT's but purposely uses the time outside of classroom sessions (between classes) to engage the students in activity. To support learning the students' (mis)conceptions are taken back to the classroom and/or discussion forum for further exploration, clarification and additional activity. This difference is important for three reasons. First the WATS approach to assessment does not demand time from the lecture for student engagement, second the assessment sets an expectation that the students need to engage with their studies outside of class and third, the data from students' performance 'informs' the lecture. This relationship between the out-of-class engagement with the assessment tasks and the in-class teaching activity, informed by the students' performance and understanding, is consistent with the more dialogic approaches to

teaching, such as those aligned with the Conversational Framework (Laurillard, 2002) and Just-in-Time Teaching (Novak *et al.*, 1999). It also supports Bligh's (1998) suggestion that feedback [following engagement] should be an important and continuous process throughout a lecture. The learning environment, which includes the assessment programme, now comprises teaching sessions that are more responsive to the students' needs and their current understanding. When talking about the interaction between teaching and learning Black & Wiliam (1998, p. 2) suggest "*Teachers need to know about their pupils' progress and difficulties with learning so that they can adapt their work to meet their needs*". In this work, where weekly student performance was lower, the results highlighted a need to revisit some of the foundations associated with the weekly task. In cases where the students demonstrated an acceptable level of understanding, there was an opportunity to stretch the students and progress through different cognitive demands. In either case the teaching sessions were now better associated with the students' demonstrable understanding and were more student-centric.

Building on the difficulties associated with increasing student numbers, Race (1998) notes the challenges of the current HE system and, as a precursor to offering ideas for class engagement, writes about "*more students and less teachers, leading to less chance for teachers getting to know their student, and in turn less opportunities for teachers to stimulate students' motivation levels*" (ibid p 51). Fortunately a central benefit of assessment is the opportunity assessment provides for us to *get to know our students* (Rowntree, 1977). Teachers, as well as students, therefore, are beneficiaries of good assessment. This is particularly true of the WATS approach to assessment where the data relating to students' weekly engagement and performance immediately flows to the teachers. Naturally, there needs to be a willingness to engage with the engagement/performance data. Black *et al.* (2008) offer assessment for learning as being a way of thinking or rather a philosophy. Hence, for the data to create positive consequence for learning, the teachers need to have an affinity with this (assessment for learning) way of thinking and act on the data.

The assessment tasks engaged the students in out-of-class activity in ways that were not previously apparent. The out-of class activity, which typically consolidated and reinforced the previous teaching session, also prepared the students for the upcoming lecture by engaging them in tasks on which the upcoming sessions would build. Further, in addition to the benefits of constantly being challenged to think about the module, and being better prepared to assimilate the links between the sessions, the students were now committing time to their studies in a way that was more aligned with the description in the Definitive Module



Document. Many students commented positively about the assessment programme and how it encouraged them to learn in ways they would not have done otherwise.

### 6.2.1 Potential Challenges to teaching

Despite the numerous benefits that the regular assessment programme brought to the teaching team, such as increasing the levels of student engagement and gaining evidence on which to appropriately adapt teaching sessions, the assessment programme also raised potential challenges. These potential challenges have been identified as *alignment*, *fragmentation* and *language*.

#### 6.2.1.1 Alignment

Many students commented positively on the way the WATS helped them engage each week and revise that week's lecture, for example,

*i think that wats is a good way of keeping up with your studies and pushing yourself to learn the weekly topics taught in the lectures, (S69, 2004-05)*

Some students, however, suggested a disconnect between the lecture and weekly assessment task,

*i like the way in which wats means that you are constantly using formula that you have learned every week in one form or another. i feel that it is beneficial to learning, however, i am annoyed by the fact that sometimes we are taught the material we need to know for that weeks wats, after the submission date. if the lecture had been before, it would greatly improve overall marks. (S85, 2004-05)*

The threat to alignment (between the lecture and assessment task) arises from a need to keep to the planned lecture schedule, and hence sufficiently prepare the students for the associated task while also drawing on their conceptions to adapt the lecture. Teaching adaptations, by definition, cannot be planned too far in advance and are created as a consequence of the students' demonstrable understanding. Too much adaptation and the students may not be sufficiently prepared to respond to the upcoming task. Too little and the lecture experience becomes too content-centric, the students conceptions are overlooked and hence do not feed into the teaching sessions. There is a tension between adapting the lectures and keeping the teaching session to a schedule.

### 6.2.1.2 Fragmentation

Each of the weekly tasks focused the students' effort on specific areas of study. They were practice-oriented and set out to stimulate student effort on that week's lecture topic. While this was consistent with the suggested need to *"break down the key concepts into constituent parts, and sequence their introduction in the teaching programme"* (Thomas, 2008, p. 125), breaking down and creating a specific topic focus for the assessment tasks had the potential to encourage the students to adopt a fragmented approach to their studies. That is the students may have not been exploring the links between the topics but rather viewing them as unrelated entities. To counter this challenge, some of the tasks specifically set out to integrate some of the concepts. Being aware of the issue meant that the teaching also had to function at an integrative level. The assessment tasks were only part of the learning environment and the in-class teaching and online activity provided an additional opportunity to counter fragmentation issues and help establish an integrative approach to learning. Inappropriately supporting a fragmented study pattern is likely to lead to a surface approach to learning (Ramsden, 1994).

### 6.2.1.3 Language

Some students raised the issue of a difference in the way the assessment tasks were written and presented compared with their experience of the in-class examples. Additionally, some students noted that the worked solutions appeared to use solution methods they had not previously seen. Worked solutions are useful to help students grasp what is expected and to provide additional insights into language and problem solving strategies (Bloxham & Boyd, 2007). While the potential to confuse students was not a design feature of the assessment programme, there are benefits in letting the students see how problems could be presented differently and also allowing them to see the different ways in which they might be solved. Experts, for instance, do not memorise facts or equations, nor is their knowledge fixed to specific situations. Experts' knowledge *"is connected and organized around important concepts and is conditionalized to specify the contexts in which it is applicable; it supports understanding and transfer (to other contexts) rather than only the ability to remember"* (Bransford et al., 2000, p. 9). A useful side effect of the *perceived* differences in the way questions were presented and solved is the opportunity to expose students to different behaviours and also be alerted to regions of developmental schemas that are not dualistic. Prince & Felder (2006, p. 23) write of the need to *"promote intellectual development, challenging the dualistic type of thinking that characterizes many entering college students, which holds that all knowledge is certain, professors have it and the task of students is to*

*absorb and repeat it*". In some sense this perceived difference might help to alert the students to pluralistic thinking and expert behaviours.

While noting the benefits and potential challenges to teaching, it is worth reiterating that teaching does not equal learning. While the function of teaching is to facilitate learning, learning is not always the observed outcome. It is argued, however, that the teaching structures supporting this assessment programme are likely to lead to learning. The assessment programme has supported the students' wellbeing and the teaching sessions have been established as part of an aligned curriculum that integrated the out-of-class assessment activity with the in-class activity. The following section looks at the evidence that the assessment programme led to student learning.

### 6.3 Enhancing student learning

Evidence on the enhancement of student learning takes many forms. The following discusses indicators of enhanced learning through student engagement, facilitating student collaborations and ultimately student examination performance.

#### 6.3.1 The influence of regular assessment tasks

Student engagement was presented in Chapter Five from two perspectives. First, the number of students submitting a response to the weekly task and, second, the contributions made to the module discussion forum.

Across the cohorts around 90% of the students submitted a response to each week's assessment task. Further, given that the students' engagement was focused on activities aligned with the learning outcomes, distributed across the subject area and the semester, and led to prompt and personalised feedback, the students' engagement was likely to lead to learning. Providing the students with opportunity to practise and stimulating appropriate engagement, which includes the level of the challenge and the frequency of engagement, was integral to the *learning-oriented* theme underpinning the development of the assessment programme and is offered as good educational practice (Biggs, 2003; Chickering & Gamson, 1987; McAlpine, 2004).

Forbes & Spence (1991, p. 97) suggest that "*success in engineering subjects with high numerical content is strongly related to successful experience in tackling tutorial examples.*"

Benefits of regular assessment include notions of setting high expectations and distributing the student effort across the semester and the curriculum. Crosling (2008) highlights the importance of regular assessments since they serve as a framework for students in their cognitive development. Chickering & Gamson (1987) and Gibbs & Simpson (2004) offer *time on task* as good educational practice. Time-on-task was noted as an important variable in predicating success in a School Study (Karweit, 1983). Although Karweit suggests “*other factors were (more) important, such as family background, time-on-task is very significant, in a practical way, because this, (time-on-task), is one resource that educators can control*” (ibid p. 1).

The weekly tasks were designed to distribute the students’ effort each week on guided and structured activity. Typically the assessment activity was intended to take around an hour of student effort. Some students note the WATS take more than the suggested time.

*in theory you should spend 1 hour per week on each sheet. so far i believe i have spent no less than 4 or 5 hours on each sheet*  
(S16, 2003-04)

*the sheets are only meant to take 1 hour a week, in practice i have often spent over 3 hours trying to figure out the answers!!* (S69, 2003-04)

The credit point weighting of the module implies that the students should expend around 150 hours on the module and so even if students are spending more time than the suggested one hour, the tasks are still beneficially pacing their engagement with the module. Rowntree (1977, p. 126) notes the beneficial pacing effect of regular assessment and asserts that “*students are held to benefit from the way in which regular assignments and other gradable events structure their time for them...*” Being *held to benefit* suggests the students are somehow made, or forced, to gain from the experience. And so, while the students might have had little choice but to participate, the outcome will be positive. The explicit intent to force, rather than encourage, the students to participate for their own benefit was a core feature of this assessment programme. Although one of the potential issues arising with regular assessment is that overt structuring of student activity may limit some of the control of when and what the students study, no students raised this as an issue. Indeed, in support of the assessment programme and Rowntree’s observation, comments by the students suggested they *liked* having a structure imposed on them.

*I think it is a good approach to learning because it enables or rather "forces" us to work on the module every week, and this kind of helps sometimes* (S100, 2003-04)

*it actually makes you do the work, or basically we are forced to do it also makes us learn what were doing. (S62, 2005-06)*

Other quotes suggested the students were less enthusiastic about the regular tasks but still felt they were helpful:

*As the semester went on I got more and more frustrated with having to WATS every week, however I always knew in the back of my mind that it is going to benefit me. Overall I still think it is a good idea (S83, 2003-04)*

*is slightly tedious didn't enjoy doing it but I believe it necessary and that it helped and would recommend it for future years reluctantly (S85, 2003-04)*

When talking about the benefits of regular assessment Rowntree goes on to say “No more ‘swanning around’ and ‘goofing off’ for two months of a term or two years of a degree programme followed by a final flurry of intensive effort prior to the terminal assessment”. This point is also picked up by the students when they write, for example,

*It encourages you to invest time each week throughout the course as opposed to last minute cramming which is good. (S97, 2003-04)*

*I think it motivates students to be involved more, doing revision every week rather than leaving it to the last minute. (S18, 2005-06)*

Although it would have been more encouraging if the students had engaged with the module of their own accord, it is apparent that the assessment programme was a significant driver in forcing their engagement. Forcing students to engage with the module, through low stakes weekly assessment activity, is likely to demonstrate to the students the benefit of regular study. The students are major beneficiaries in terms of their learning on the module and by working in an environment which helps demonstrate how a regular study pattern can help their studies. The benefits of regular study are relevant to other modules and other levels of study.

The high level of regular student engagement, as evidenced by the number of submissions to the assessment tasks, is supplemented by the number of contributions made to the discussion forum. While there is a maturation process as discussion forums become increasingly more embedded within the learning environment, the number of contributions to the Fluid Dynamics and Thermodynamics discussion forum far exceeded those made to the discussion forums associated with other modules. The numbers of contributions to the

discussion forum were: 130 (2001-02), 157 (2002-03), 165 (2003-04), 859 (2004-05) and 577 (2005-06). The majority of the discussion forum activity was led by students and was oriented around the assessment activity. These figures contrast sharply with similar modules taken by the same group of students where there was little evidence of activity on the discussion forum. Further, the students were asking questions throughout the semester about the various topics of study. They were not, as they were doing elsewhere, focusing on housekeeping issues such as *“where are the answers to tutorial sheet 3”* or *“when do I hand the lab report in?”*

Regular assessments and the subsequent regular student engagement bring an additional opportunity to offer regular feedback, as there is now something *upon* which to provide feedback. This is important since *“action without feedback is unproductive to learning”* (Laurillard, 2002, p. 55). Student action that is regular and supported by regular feedback is, therefore, likely to support the students and their ongoing learning. Feedback does not only provide corrective advice but can also raise the students’ awareness of the areas they are struggling with. In doing so, the students might be stimulated to think about their study behaviours and its impact on their learning. Some students noted the benefit of the assessment programme in highlighting what they understood and what they didn’t. Haigh (2007) raises this point when he writes of the value of regular assessment followed by prompt feedback. He suggests *“they [the students] might receive immediate feedback to remind them how much they know, or don’t know, which might encourage extra study. If a course were progressive, each session building upon foundations laid in its predecessor, then after reading and review towards a quiz, a student might enter the classroom with greater knowledge, hopefully greater understanding, and be able to move ahead more confidently. Additionally, the risks of any student becoming lost and leaving themselves too much to adsorb in an end-of-class ‘cram’ could be reduced or, at least, recognized in time for the problem to be remedied”* (ibid p. 461). In Haigh’s example, the regular assessment and feedback positively impacts on the students’ self awareness, their study behaviours, their engagement in class, and their understanding and confidence in the subject; all of which is likely to perpetuate a willingness in the student to further explore the subject area (Barnett, 2007).

Central to the success of student engagement was the use of technology to administer many of the assessment processes. Irrespective of the weekly and student nature of the WATS assessment programme, which is especially demanding, Gosling (2007, p. 172) notes, after indicating the benefits of feedback on learning, that *“a not uncommon fault within a semester system, is that students only find out how well, or badly they are doing after they receive*

*feedback..., by which time it is too late to take any remedial action*". Such a comment could not fairly be levelled at this assessment programme.

Having identified the beneficial pacing effect created by the regular assessments, the following section discusses the influence of the grading system on the student engagement.

### 6.3.2 The influence of marks on student engagement

Assessment for learning is characterised by assessment practices where grading systems are subservient to the development of student learning. Using high-stakes summative assessment rigorously but sparingly, rather than as the main driver for learning, is offered as one of the conditions of *Assessment for Learning* by the University of Northumbria's Assessment for Learning CETL<sup>13</sup> (McDowell et al., 2006). While proponents of assessment for learning would discourage an emphasis on grading, it is perhaps too ambitious to envision assessments as tasks that encourage student participation purely for the joy of learning. Haigh (2007, p. 458), reports that "*since success is measured by the marks they receive, students strive to be efficient and effective mark winners. Marks are the measure of any particular learning task, so tasks given the highest marks are also those that receive the greatest effort*". Snyder (1970) also reports that, following introduction to a new course, "*they [the students] first determined how much the homework would contribute to the final grade*". Following the exploration of students' views relating to out-of-class quizzes Smailes (2003, p. 397) also notes that "*all students appeared to focus on grading. A large majority, 80%, of respondents cited the provision of grades as essential elements of the quizzes*".

In addition to the tension between stimulating learning and recording learning, the UK Quality Assurance Agency (QAA) raise another consequence relating to the use of marks in all assessment tasks. According to the QAA (2007, p. 1) "*over time, as marks get attached to an ever-widening pool of study activities, the weighting of any one task becomes smaller and smaller. Since everything seems to count, everything matters a little, but little matters a lot. Staff can find themselves with an unmanageable marking load, administrators have to run systems that count innumerable piles of small change, and students may feel pressed to turn out and turn in the latest of their set work requirements, rather than necessarily doing it well or trying to learn from it.*"

---

<sup>13</sup> CETL's are Centre's for Excellence in Teaching and Learning. They were funded by the Higher Education Funding Council for England for the period 2005-2010.

There is clearly a tension between aligned teaching environments where assessments are an integral feature of the student activity, and the relationship between assessment and student and teacher effort.

The decision to include the students' grades from the weekly tasks in their overall performance for the module has been vindicated by the high levels of student engagement and also their responses regarding engagement. Student feedback in Section 5.5, for instance, noted a positive response to the statement '*Overall I would rate the WATS as excellent (2.44)*'. There was a positive response to the statement '*I think other subjects could benefit from the WATS approach (2.23)*' and, although also positive at 2.76; '*I would still do the WATS even if they did not count towards the final grade for the module*', additional analysis shows that fewer than half the students (~47%) indicated they would have engaged with the WATS if the grade had not counted. Non-engagement reduces the opportunity to practise, provide prompt feedback, establish in the students a self-awareness of their current conceptions and gain evidence in which to shape and adapt the teaching sessions.

The language used by the students also captures the importance of grades when they note how they influenced their study patterns:

*I think it is a very good way of getting people to do the work. i know that if this project was not part of the assessment that i would probably not have done as much work as i have done. (S171, 2004-05)*

*if the work had of been optional, or just set during lectures as follow up work, i feel i would not have completed it, and would be in a worse state for the coming exams. I feel that wats is a good idea and should be continued in the future. (S15, 2004-05)*

The influence on the grading structure of the assessment programme on the students' motivation is not unique to this discipline. Following the introduction of a continuous summative assessment programme to a Business Taxation module, Trotter (2006) reported comments by her students that appear to mirror those made by the students exposed to the WATS approach to assessment. Trotter's students also commented how the assessment changed their behaviour and how they were now working and learning as they went along rather than cramming at the end. When reporting on his introduction of marked weekly quizzes, Haigh (2007, p. 461) suggests "*now, there is an incentive for each student to engage with the class and to review their notes from the previous session in order to win the quiz marks*". Smailes & Russell (2004) also report on the importance of grades to motivate



student engagement with learning activities. After removing a summative component from online quizzes; that is, to establish a set of tasks for formative purposes only, the students' engagement reduced. While these findings are seemingly summarised by Rowntree (1977, p. 23) when he writes "*assessment can be used as an instrument of coercion, as a means of getting students to do something they might not otherwise be inclined to do*", the results of this research would imply that it is the consequences of the assessment, i.e. the marks, that coerce the students and not the assessment (for learning) activity. The relationship between the consequences of assessment and student engagement which, in an aligned curriculum, is likely to lead to learning, was probably overlooked or not given enough prominence in the design of the module's assessment prior to the introduction of the WATS approach to assessment. Hence, the lack of regular and appropriate engagement and the consequences that flow from the engagement probably led to the high failure rate that stimulated this research programme. Although the students' performance on the weekly tasks was included in their overall grade for the module, each weekly task only accounted for around 1.5% of their final grade. This figure makes each task a low-stakes assessment activity, and the activity more formative in its intent, as consistent with work reported elsewhere. Battles, (2000) for example, reports on his use of weekly note cards where 1.0% of the module grade is allocated for each week's activity.

This assessment programme purposely exploited the assessment-engagement relationship and, through the creation of weekly low-stakes assessment tasks, established weekly student engagement. Although there is the suggestion that, for summative assessments, "*the students will be singularly unwilling to admit their mistakes*", and in these situations "*error signals punishment*" (Biggs, 2003, p. 142), failure on these low stakes tasks did not create significant detrimental consequences for the students. This assessment programme, it is argued, balanced using a marking system to stimulate student engagement while also encouraging them to share their misconceptions. In this low stakes assessment the notion of "*error signalling punishment*" does not apply.

### 6.3.3 Empowerment and the timing of student submissions

One of the perceived benefits of e-learning is the notion of student empowerment and the suggestion that it allows the students to have more control over *where* and *when* they study (Jenkins & Hanson, 2003). Within the limits of the weekly timeframe, the same benefits also arose with the WATS approach to assessment. Providing students with the freedom to decide when they work on the task and when they submit their responses is important in terms of flexibility. Many students indicated they were working whilst studying (see Table 2-

6), and establishing an assessment programme that can accommodate external pressures is important for flexibility, learner choice and the perceived sense of control it provides to the students. Many students chose to submit their work late in the evening and exploit the midnight submission deadline. Non-computer collected assessments are unlikely to offer the same benefit to the students.

There are, as indicated in Table 5-3, many instances where the students submitted work on the last day and also many students seemingly working very close to the submission deadline. Such submission profiles are not unique to these students, this discipline nor this university. Reporting on Sports Science students at a pre-1992 UK university, Bryan & Glasford-Brown (2005) demonstrate the significant increase in the use of formative assessments as the summative assessment deadline approached. The summative assessment reused some of the questions presented in the formative assessment. A study outside the UK also demonstrated similar submission profiles (Smaill, 2005). Indeed, Smaill writes; *“about 90% of student practice activity for this assessment occurred in the five days before the assessment, with a full 50% taking place in the last 36 hours (8 p.m. on Saturday to 8 a.m. on Monday)”* (ibid p. 661). The practice tests were typically available for a three week period. Smaill also reused some of the practice questions in the formal online assignment.

McDowell & Sambell (1999, p. 80) imply the normality of us all working to deadlines when they write *“although students may find what they are doing interesting, we all tend to need the additional push of a deadline to meet to help us focus and find our way through competing pressures on our time”* [emphasis added].

Accepting that many students submitted their work close to the submission deadline, there is evidence that many students were thinking about and working on their tasks in the days preceding their submission. For these students a late submission did not necessarily imply an inappropriate study pattern. It is not clear, however, if this is true for all the students. Across the cohorts, around 16% of the students were submitting their work within two hours before the submission deadline (see Table 5-4). The tasks, as described in Chapter Three, are consolidatory and are likely to represent around one to two hours of student effort. Putting the students' submission times in context with the nature of the weekly assessment tasks implies that, if the students were submitting their work within two hours of the deadline, the likelihood is that they were undertaking the work within this period too. Clearly, there is little sense in students doing their work during the day and waiting until 23.00 hrs to submit it.

Aspects of the submission profiles, and the suggestion that a minority of the students' study behaviours is inappropriate, are replicated across the WATS cohorts. Arguably a more appropriate study pattern is one that displays distributed effort and attention throughout the available study period and not crammed towards its end. It is also suggested that those students adopting a more meaningful and less cramming study pattern will better understand the subject; that is, they will have more opportunity to read around, situate and reflect on their growing knowledge. There is a positive, yet weak relationship between the total number of hours the students submitted their assessment tasks prior to the submission deadline, and their overall WATS score ( $r=0.21$ ).

#### 6.3.4 Learning through competition

By design, the weekly tasks were student unique and required an individual response. In addition to the personalised feedback e-mails, the cohorts were provided with a weekly updated *WATS League Table*. The *WATS League Table* set out the students' weekly and ongoing performance for all the assessment tasks. The motivation behind the creation and sharing of the *WATS League Table* was to create an environment where the students were motivated by being seen to be learning (Race, 2005a). The ability of the *WATS League Table* to provide this opportunity and the potential competition it creates to stimulate learning is captured by one student when he writes

*... putting a league table increased the need to do the work because everyone else could see your results (S142,2005-06)*

(note: the league table uses identifiers rather than students' names)

Other feedback from the students on the use of the *WATS League Table* is positive and includes their agreement that the WATS League Table is excellent; rated at 2.07 (Table 5-14), and their comments that demonstrate the motivation created by the *WATS League Table*.

*the league table makes it competitive between students, so everyone wants to win it and therefore studies hard. simple idea, very effective more modules should use wats (S10, 2006-07)*

The principles in which competition can be both healthy or unhealthy for student motivation and learning are offered by Shindler (2008). As with the distinction between formative and summative assessment, the difference appears to be in the consequences it creates. Healthy competition does not characterise the competitive goal as being important, it is the

learning that is characterised as valuable. Healthy competition does not limit the potential for success, nor should it have any long term effects. The WATS approach to assessment is firmly articulated as being learning-oriented. The ultimate goal of the assessment programme is student learning, not reaching the top of the league table. Further, given that the assessment programme is criterion referenced, rather than norm referenced, every student can achieve an equal performance. The significance of criterion referenced assessments is that the students are judged in isolation from their peers and the knowledge of the subject domain is accessible for all to grasp. The goal of the assessment programme, student learning, is not limited to a few students, a point that is beautifully captured by Rowntree (1977, p. 51) when he points out that “*the Pythagorean theorem does not flicker and grow dim as more minds embrace it*”. The competition that arises from the assessment programme is seen as a beneficial side effect that is exploited to create a sense of competitive excitement. The notion of competitive excitement also features in Shindler’s principles of healthy assessment and is picked up by the students when they write,

*i particularly like the league table approach as it is always fun being competitive with your mates and taunting them when you win! (S63, 2005-06)*

*WATS has allowed me to take in much more information than simply learning from lectures. I have enjoyed doing them and the competitive element is fun... (S29, 2003-04)*

While the students note the benefits of the competition created by the assessment programme, there is also observable collaboration between the students. Learning through collaboration is an important feature of a learning environment and is discussed in the following section. In this instance competition and collaboration do not conflict, but co-exist to help student learning. Indeed, to show the possibility for individuality and collaboration to co-exist, work on ‘*Learning that Lasts*’ suggests that it is “*active and interactive, independent and collaborative*” (Mentkowski & Associates, 2000, p. 240). This co-existence of independent and collaborative learning resonates with the work presented here and also the requirement for a learning environment to include both student-centeredness (individuality) and community-centeredness (collaboration) (Bransford et al., 2000).

### 6.3.5 Learning through collaboration (Collaboration versus Competition)

Section 6.3.4 discussed how student learning might be enhanced by developing a competition that is short-lived and secondary to learning. The WATS approach to assessment set out to enhance learning and hence provided a learning environment that benefited from the competition. Student learning, however, is also enhanced if there are opportunities for student-to-student collaborations. Student collaborations provide an opportunity to engage the students in dialogue, let them hear alternative perspectives and be presented with an audience to whom they are required to articulate, and in some cases justify, their understandings.

Various suggestions are offered on how to engage students, in-class, using active learning techniques (Angelo & Cross, 1993; Gibbs et al., 1992). Many of these suggestions are focused around small group collaborations and reap the benefits associated with student-to-student dialogue. This assessment programme established similar situations and created out-of-class student-to-student collaboration. Among themselves, the students were discussing their misconceptions, sharing problem solving ideas and learning from each other. Evidence of student collaborations are found on the discussion forum and in the observations made by the students.

A student-to-student exchange on the discussion forum that demonstrates students helping each other is exemplified by the following:

*After asking my house mate for some help we came up with this formula*

$$\text{ratio} = \text{viscosity} / (\text{density} * \text{diameter} * \text{velocity})$$

*We derived this by supposing that the ratio is a dimensionless quantity, if u do the dimensional analysis the right hand side of the equation should end up dimensionless. Then u plug in the bottom and top ratio for the speeds.*

*now this makes sense but the answers i got seem a bit ludicrous*

*Vmin=34406m/s Vmax=3822950m/s so im not sure if its right.*

To offer support another student responds ...

*I think that you've got the right method, you must have just forgotten to include the  $10^{-6}$  factor for the viscosity. You should get quite small speeds, which I think is because the cylinder is so small.*

This is subsequently corrected by another contribution to the forum,

*Hi . I just derived the formula, and I got  
ratio=(density\*diameter\*velocity)/viscosity instead of  
ratio=viscosity/(density\*diameter\*velocity)/viscosity.*

*Miu is on the bottom*

*maybe that's the reason why you have such weird values .... 07/05/2007*

Three general observations can be made regarding these (typical) exchanges on the discussion forum. First, the students were seeking advice on a regular basis. This suggests the students had been stimulated to think about the subject each week and were actively engaging with tasks relating to the current lecture. This implies they are consolidating their learning and becoming better prepared for the upcoming lecture. Again, this point reinforces the argument that submitting work close to the submission deadline does not imply cramming. Second, the students were generally not directing their questions to the teaching team. This is important since it demonstrates how they valued the input of their peers who were also forthcoming in offering prompt and supportive advice. Finally, the student-to-student online collaborations showed that many students were willing to describe and share their misconceptions and seek help through the open medium of the discussion forum rather than through a personal, closed, e-mail directed at the teacher. This last point is important for two reasons. First, there would be little opportunity for the teaching team to respond individually to large numbers of student-unique e-mails. Responding to large numbers of e-mails on a regular basis is not a sustainable activity in the current mass higher education system. The peer-to-peer support, facilitated by the discussion forum, helped the efficiency of the assessment programme and created a sustainable support system. Second, in facilitating the peer-to-peer dialogue, the discussion forum established an opportunity for the students to enhance their learning. They were doing this by reflecting on what they knew, articulating their understanding and formulating questions or responses. This activity is also likely to be a generative and learning oriented experience.

The number of contributions made to the discussion forum and the observations of students responding to each other suggests the assessment programme supported an environment where the students sought and benefited from the views and support of their peers. Although there are benefits in bringing peer support activity to the classroom, this approach to assessment has established additional out-of-class peer support that previously was not as evident. Further, the out-of-class student collaborations helped the efficiency and sustainability of the assessment programme. The students were helping each other and not overly relying on the input from teachers. These observations support the themes underpinning the assessment programme; being learning oriented and resource efficient.

### 6.3.6 Student performance

Numerous benefits have been offered as a consequence of developing and using the WATS approach to assessment. The students were more engaged with their studies and they were distributing their efforts across the topics and the semester. Additionally, the students were provided with prompt and personalised feedback, which was also available to the teachers to create more student-centred teaching sessions; all of which are likely to lead to learning. Ultimately, however, the success of the assessment programme is likely to be judged on the students' performance in the examination. This section discusses student performance.

#### 6.3.6.1 WATS versus examination scores

There is a positive relationship between the students' examination grades and their WATS grades ( $r=0.53$ ). This supports the thesis that the assessment programme leads to student learning. In all years, however, the majority of students scored higher marks in the WATS than they did in the examination. Scoring higher marks in coursework than examinations is not unusual and is reported elsewhere (Rowntree, 1977). In the case of a large physics class exposed to regular assessments, Thoennessen & Harrison (1996) note that only a few students performed better in the final examination than in the homework. Reasons for higher WATS grades are offered here as the opportunity for students to review the available resources and seek help from their peers and teachers. The students have more time to reflect on and respond to the task than they do in the examination. It is also likely that the weekly tasks are less stressful than the examination. This point is also reinforced by Biggs (2003, p. 176) when he writes of assignments or 'term papers' and notes that "*the assignment is not distorted by immediate time demands or the need to rely on memory*". He goes on to say; '*in principle, it allows for deeper learning; the student can consult more sources, and with that deeper knowledge base synthesize more effectively*'. To counter the

potential for plagiarism with assignments he notes that *“the take-home, which has shorter time limits, makes plagiarisms more difficult”*. Bridges *et al.* (2002, p. 46) also contrast exam and coursework grades and suggest *“the examination conditions themselves may effectively diminish the candidate’s performance. A weakness in the ability to organise intellectual material and communicate effectively in time-constrained conditions (important as this is) may mean that the assessor does not really find out what the candidate knows and understands”*.

While discussing continuous assessment, Miller & Parlett (1974) note how some in-course assessments may create stress in the students whereas others may not. Again, the distinction appears to be in the use and consequences of the information that flows from the assessment. When talking about the results of continuous assessments being used to determine progression onto an honours degree, one of Miller and Parlett’s interviewees describe the stress and potential combined effects of poor performance. After noting how ‘staggering’ the impact of an individual assessment in a continuous assessment programme can be, they go on to say that *“[doing bad on] one essay wipes out everything, no merit, no honours, no university, no career, trouble with your family...”* (ibid p. 93). Miller and Parlett’s example refers to a collection of essays, where each essay was high stakes and the students’ performance on the essays were used to make important judgements about their ability to progress. While the assessment programme in this example was continuous in nature, it seems that it was more aligned with assessment *of* learning rather than assessment *for* learning. In contrast, low stakes assessments, such as those in the WATS assessment programme, where learning is intended as the primary consequence rather than judgement or selection, is unlikely to be as stressful, or to lead to consequences as reported by the student in Miller and Parlett’s review. The intention of the WATS approach to assessment is to stimulate learning and avoid disproportionate or negative consequences. Indeed, one student writes,

*a highly stressful experience! seriously!! but i can say its better than having a heavier weighted exam paper. (S54, 2003-04)*

Having a less stressful experience with the WATS, compared to the examination, is picked up by another student when he writes,

*i think that it is a good way to assess students and helps take pressure off the exams. (S185, 2005-06)*

The same student goes on, however, to suggest that the WATS might be more appropriately scheduled as a fortnightly activity



*... however i think that submissions for the wats should be fortnightly instead of once a week. this would reduce stress caused by continuous working on the wats. (S185, 2005-06)*

### 6.3.7 Student improvement

The intention with the WATS was to expose the students to the same type and level of challenge. Each student was exposed to assessment tasks that might be observed as being relatively easy, or functioning at lower levels of a cognitive hierarchy, as well as being equally exposed to those tasks that might be seen as being more difficult and functioning at a higher level of a cognitive hierarchy. This created a sense of parity in the student assessment experience. Analysing the impact of the assessment programme reveals a disparity in who benefits most from its implementation. Although the results show an increase in the majority of examination score percentiles, there are, larger increases in examination scores around the middle percentiles. This trend and position of highest increase is consistent across the cohorts; 50th in 2002-03 and 2004-05 and 40th in 2003-04. These results may have arisen since the better performing students are likely to be more engaged in their studies and will already have been tackling homework problems and tutorial sheets, and reading around the subject. For the better students, the WATS provides a grade for the activity they would probably already have been undertaking. While they will benefit from prompt feedback, the notion and importance of regular engagement is not new to them. Conversely, the lower performing students are likely to be less engaged and possibly to exhibit inappropriate study behaviours. For these students, although the WATS may have forced their engagement in the actual task, their engagement may not have been so learning oriented. They may have been overly reliant on their peers for support and may have adopted a surface or strategic approach to their studies. Their motivation may have been driven by a desire to pass the task and move on to the next week's activity. For these students, the tasks may have been less about helping them align the in-class activity with the out-of-class activity and drawing on and making sense of the feedback, but more about scoring marks.

Comments from the students included comparisons of where they are as a consequence of the WATS activity against where they may have been had they not been exposed to the WATS approach to assessment.

*I have learnt a great deal more through doing Wats than i could have done using other methods of revision. (S159, 2004-05)*

*It has been a long process! It feels good to finally finish it! If WATS was not around I have no doubt that I would do considerably worse in this module! We will see the outcome in the summer. Now it's time for revision and re-doing WATS questions will help along with the worked solutions. Maybe I will do someone else's WATS so I have different questions to do on my weaker areas. (S52, 2004-05)*

*Overall I think the wats is a good idea, without it my understanding of the subject would be a lot worse. I did however find it very time consuming each week. I feel my time could have been spent better on other subjects. I think wats could be used in other subject areas to improve learning, but maybe fewer questions (S135, 2004-05)*

#### 6.3.8 The deviant case (2005-06)

The 2005-06 examination performance is markedly different from the other cohorts exposed to the WATS approach to assessment. As with other cohorts, the worked solution was released to the students *after* they had submitted their work, and after the submission deadline had passed. The intention was that the students would review the worked solution and see where their method of working was similar or different to that of the worked solution. The students' engagement with the worked solution was designed to follow their engagement with the task.

Following the examination results of the 2005-06 cohort and discussions with students, it appears that some students (in the 2005-06 cohort) were subverting the assessment programme and its intentions to engage them in personal activity. They were responding to the tasks, receiving prompt feedback, and able to ask questions on the discussion forum, but it seems that many students had gained access to the worked solutions *prior* to their engagement with the weekly task. The worked solutions were being accessed from the web site of the HEA Engineering Subject Centre. This information came to light after an interview with a 2005-06 student. A part-transcript of the interview is presented in Section 5.5.4.

Responding to the WATS with the worked solutions to hand implies the students would have been *following* the assumptions and the problem solving methods. The designed activity was to challenge the students to make their own assumptions and establish their own problem solving approaches. Using the worked solutions prior to engaging would not have helped the students' learning and so their 'good' WATS results may have given them a false sense of

security. That is, the grades may have suggested to the students that they understood the subject whereas in actual fact all they were doing was following a worked solution. Teachers too would have been fed performance data that did little to inform adaptations to teaching. The students' learning would have suffered as a consequence. The inappropriate study behaviours of the 2005-06 cohort reinforces the benefit of the underlying themes of the WATS approach to assessment and the need for proper student engagement and practice.

Plugging numbers into equations without focusing on the underlying principles is unlikely to lead to learning. In the extreme the students would have been applying, or plugging, their student unique data into an equation. The problems associated with a so-called 'plug-and-chug' approach to studies is reported by Cahyadi (2008).

While talking of a high success rate being in part due to the feedback the students gained and used to polish up their submissions, Yorke (2003, p. 481) suggests "*it is not clear whether the student has developed sufficiently to deal satisfactorily with analogous work without the support of the teacher*". This creates a false sense of security, or overconfidence, which is conjectured as having happened to many of the 2005-06 cohort. In 2005-06, the students were over-reliant on the worked solution as they tackled the tasks and could not abstract their knowledge to adequately tackle the examination questions. Importantly, in having a false sense of security, the students would not have been aware of what they knew of the subject and what they did not, and would not therefore have been alert to their own misconceptions. This situation is analogous to the pre-WATS cohort where failure rate in the module was high.

In addition to the students having a false sense of security, the teaching team would have been receiving false information on where the students were struggling, or in many cases, where they were not. Learning is enhanced if learners freely expose their (mis)conceptions. Identifying and sharing misconceptions would have been useful for both the learners and the teachers.

In many ways, the detrimental impact of the students subverting the system demonstrates the value of engaging the students in activity that is their own and reinforces how the WATS approach to assessment increased the potential for learning. Subverting the intentions of the assessment programme might provide the students with a short term gain but it will do little to support learning that lasts.

### 6.3.9 Confirming a causal relationship

Establishing a direct causal relationship between the assessment programme and the students' improved understanding of the subject is not a trivial exercise. As with similar investigations, proof beyond all reasonable doubt that the assessment programme had a positive impact is unlikely to be forthcoming. Primarily this is due to the lack of a control group. Issakson (2007, p. 6), talking about his use of continuous assessment, writes that *"despite the positive benefits observed with his continuous assessment programme it is impossible to tell whether the continuous assessment... is worse or better than any other assessment technique. The problem arises due to no control group"*.

To mitigate the lack of a control group, evidence suggesting the students have an enhanced understanding of the subject due to the WATS approach to assessment has been drawn from a number of sources. The evidence offered includes:

- There is an increase in engagement with tasks;
- The students are now committing effort to their studies both inside and outside the classroom;
- The engagement is practice-oriented and the students are challenged to consolidate each week's lecture;
- The students are able to work both individually and also collaboratively with their peers;
- The student activity leads to the provision of prompt feedback;
- The feedback is available for teachers to adapt the teaching sessions and make them more student-centric;
- Any disengaged students can be identified early.

Central to the benefits, and an important outcome of the assessment programme, was the higher than previously observed level of regular student engagement. The level of student engagement is evidenced by the number of student submissions, the contributions to the discussion forum, and the students' own responses relating to the WATS assessment structuring their activity and forcing them to learn. The assessment programme helped establish study behaviours and habits that were useful here and elsewhere. Howe (1987, p. 143) notes that *"there is necessity for the skills that are involved in effective learning not only to be learned but to be used and repeated until they become habitual"*. The present study would add to this a need to inculcate appropriate study behaviours in the students until they become habitual. Indeed, reporting on the use of weekly notecards to establish students' misconceptions, Battles (2000) also notes how the approach reinforces good study habits.

## 6.4 Use of technology

Establishing and sustaining assessment activity that draws on research informed principles of good practice in assessment and feedback is becoming increasingly difficult. Principally this is due to the large numbers of students entering higher education and the constraints placed on teaching time. Handley et al. (2007), for instance, notes that academic staff are working in a setting with considerable workloads, high student numbers and a lack of resources. The following discusses how technology has supported the assessment programme from two perspectives.

### 6.4.1 Making the assessment programme a practicable proposition

This research set out to create an assessment programme that is relevant to the context, educationally effective and resource efficient. Reference to the literature relating to good assessment and feedback practice enhanced the educational effectiveness of the assessment programme. Developing the assessment programme into a system that is practicable and sustainable required the use of ICT. In this research, technologies were developed to set and distribute the students' tasks, collect and mark the students' submissions and provide the much sought-after prompt feedback. The feedback is personalised and, due to in-built intelligence, includes some diagnosis of mistakes students may have made.

The design features of the assessment programme, notably the setting of a student unique weekly task with the provision of prompt feedback, coupled with the large student numbers and the demands placed on academics teaching in universities, dictate that the development and use of technology was an essential part of the assessment programme. In setting out a context for a review of CAA, Conole & Warburton (2005, p. 17) comment that "*the resources available are seen to be static or dwindling, but Information and Communications Technology is seen to increase productivity by automating assessment task*". Indeed, the assessment programme conceived for this research could not have been sustained without the use of technology. Technology has made the design ideas a practicable proposition and subsequently operationalised the designed assessment programme.

The time taken to administer the assessment programme is shown in Table 6-1. Note that the use of the assessment programme without the use of the developed technologies is not a viable proposition. For example, with 100 students and 11 weekly tasks, a manual implementation of WATS would require around 200 hours' input. This compares to around 45 hours for the same situation using technology.

Table 6-1 Time taken to administer WATS (hrs)

Number of students	Manually administered	Technology administered
20	77	47
40	108	47
60	138	47
80	169	47
100	200	47
120	230	47
140	261	47
160	291	47
180	322	47
200	352	47
220	383	47
240	413	47
260	444	47
280	475	47
300	505	47

Comparing the time taken to administer the assessment programme against the original phase test (2001-02) suggests the WATS approach to assessment will break even (time wise) at around 320 students. Having developed the technologies, re-use in subsequent years will see the break even point drop to around 160 students in year 2 and 80 students in year 4. The relationship between the number of students and the time required to administer the WATS approach to assessment is shown in Figure 6-1.

Figure 6-1 Time to administer the WATS approach to assessment

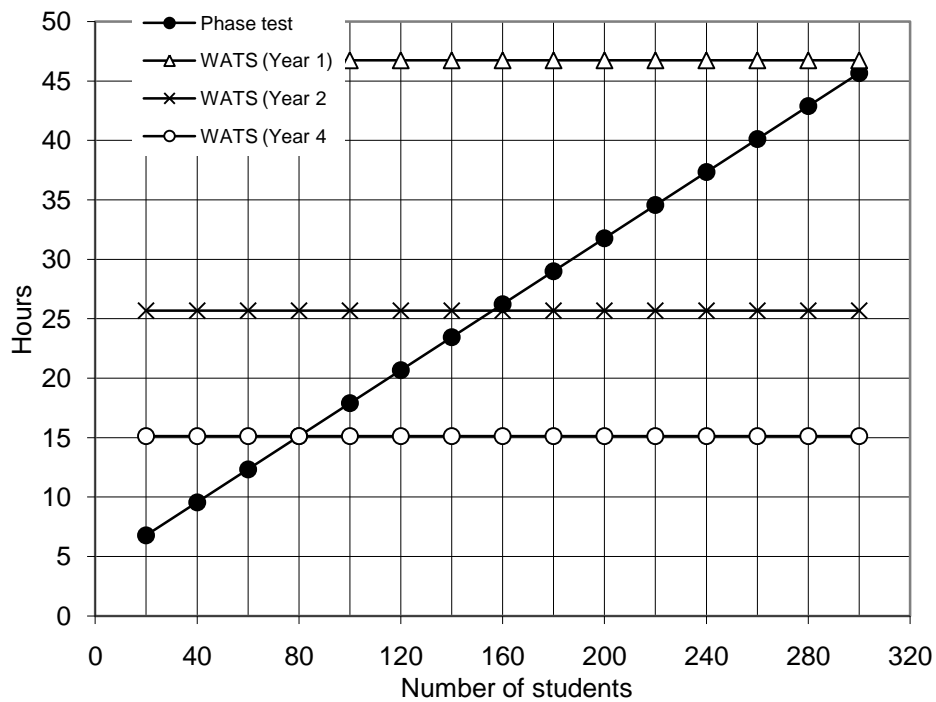

Plotting the alternative assessment patterns on an efficiency versus effectiveness matrix (Hornby, 2005) gives rise to the following.

Figure 6-2 Educational effectiveness and resource efficiency of the assessment regimes

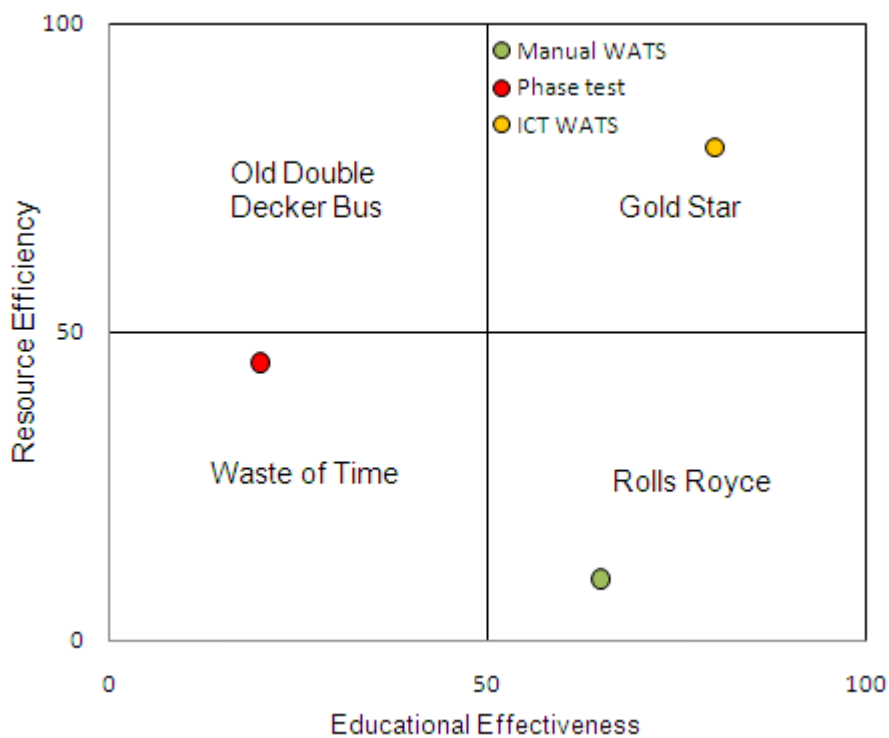

The phase test used during 2001-02 (red circle) is arguably a 'Waste of Time/Old Double Decker Bus'. e.g. The phase test has been shown to do little to support student learning.

A manual implementation of the WATS approach to assessment reaps numerous benefits but will be demanding on the available resources. A manual implementation of WATS is classified as a 'Rolls Royce' (green circle). Developing and deploying technology to the WATS approach to assessment will increase its educational effectiveness (e.g. by facilitating prompt feedback) and increase its resource efficiency (e.g. the technology automates many of the necessary and time consuming processes). Using technology with the WATS approach to assessment helps classify the assessment programme as a 'Gold Star' (yellow circle).

#### 6.4.2 Transparency of marking

In addition to the efficiency gains, other benefits arise from the use of technology. The marking rules are transparent, efficient and applied equally to all students. Not only does computer-based marking reduce much of the effort associated with marking, recording, reporting the grades and providing feedback that follows an assessment activity, which is significant where large student numbers and/or regular assessments are involved, but the marking rules are applied equally and without subjectivity to all students. Rowntree (1977) notes that *"Computer-based marking systems are not affected by attractive, polite, appropriately dressed or well mannered students. All things being equal, the unattractive, ill mannered, scruffy student has as much chance of achieving a high grade as their opposite"*.

#### 6.5 The impact of the researcher on the research

This research had a desired intent to stimulate better learning and ultimately reduce the module failure rate. Hence, the intention at the outset was that the assessment programme would be a positive addition to the learning environment. In some sense the research was already predisposed with a view about the assessment programme; i.e. Send back the feedback, it set out to make a positive contribution to the module and the students' learning. Being alert to the predisposition is important since it helps safeguard against claims of researcher bias. In this instance care has been taken to present data that both supports and counters the claim that the WATS approach to assessment has supported learning.

In addition to the potential for bias due to the intent of the research was the potential for the researcher's feelings and values to bias the research. The research represents a major



commitment of researcher time and thought. There is, therefore, a potential for bias such that the researcher's time and thought will culminate in a positive influence on student learning. Again, being alert to such a relationship is important to safeguard against researcher bias.

During the research programme the researcher's involvement with the students exposed to the WATS approach to assessment was similar to the researcher's engagement with the pre-WATS cohort. The researcher supported the laboratory study, provided support through *StudyNet* and administered the WATS. The researcher did not engage more with students in class and importantly did not prepare, or support the preparation of, any examination questions. This is particularly important since it would be easy to demonstrate an improvement in student performance by consciously (or otherwise) changing the complexity of the examination questions. The examination questions were written by the same team that wrote the questions before the WATS were introduced.

Further, to safeguard the parity of the examinations, the School of AADE operates a policy where module members write the examination paper and provide an accompanying marking rubric. The current examination paper and marking rubric, together with the previous year's examination paper, are subject to independent moderation. The moderation looks at the level and appropriateness of questions. The researcher had no involvement in any of the review or moderation process.

It is acknowledged, as discussed in Section 3.3.3.1, that the students were presented with the rationale for introducing the WATS. The introduction outlined the importance of regular study and the idea that regular study and submission of work provides teachers with something to provide feedback on. Hence the introduction was essentially a description of good teaching practice rather than the merits of the WATS approach to assessment. At no time during the introduction or subsequent interactions with the students were the students encouraged to give only positive feedback, nor was it suggested that giving favourable feedback would benefit them or the researcher. The researcher's limited interactions with the students allowed little opportunity to establish a rapport with the students, hence there was little opportunity to establish any form of relationship where students might perceive the provision of unnecessarily favourable feedback would be useful to the researcher.

Given the above, it seems appropriate to have confidence that the teaching team did not bias the examination questions to support a favourable output for the WATS approach to assessment. It seems appropriate too to have confidence that the students' views were representative of their viewpoint at the time of responding.

To provide additional support for the claims of success, and that the success is related to the assessment programme and not biased by the researcher, it is worth noting that academics teaching different modules and in other subject areas who are using the WATS approach to assessment report similar benefits to those noted in this thesis.

## 6.6 Generalisable principles

The assessment programme was developed to support a first year Fluid Mechanics and Thermodynamics module. The development was made to offset the challenges associated with the module and the high failure rate observed in 2001-02.

There are, however, numerous general principles that suggest the benefits of the WATS approach to assessment are not specific to Fluid Mechanics and Thermodynamics, nor to Engineering. Features of the assessment programme and the prevailing context in HE suggest it is usable in other subject domains. Indeed, the assessment has already been used elsewhere across UH. Naturally it has been used in other Engineering modules, but it has also been used to support Business, Pharmacy and Life Science students.

In these cases the weekly assessment tasks have also been numerical and have utilised the technologies to construct the student-unique tasks, collect the work and mark the students' submissions. In all cases, the experiences of the teachers and the students are similar to those in the engineering application.

The students welcome having a structure imposed on them, they appreciate the prompt feedback and the teachers benefit from seeing how their students' understanding of the topics are visible week-by-week. A Pharmacy student writes;

*WATS is one of the best aspects of the pharmacy degree. I was worried that my numeracy was not good enough, but am now confident that it is in fact better than that of most of the other students.*

Another student writes

*I think WATS is an extremely useful exercise. I think we should have more of it throughout the whole year as it is something we cannot escape from considering we need to pass an exam on pharmaceutical calculations.*

Although the WATS approach to assessment has been used in other disciplinary areas, there is little doubt that the assessment and the technologies used to support the assessment tasks are better suited to disciplinary areas that require a numerical response. Whilst this might preclude its use in disciplinary areas that are more discursive, the assessment programme was developed in response to a specific challenge located in a numerically based discipline. There are, however, principles of the assessment programme that are transportable and are not fixed on the use of numerical based tasks. These principles, it is argued, are transportable across the disciplines and include:

- The value of building practice opportunity into the curriculum;
- The value of regular student engagement; in this case the engagement was stimulated by the assessment tasks and a marking scheme where the students' grades counted towards their performance in the module;
- Feedback that is prompt and bears an opportunity for the students to be seen to be learning;
- The collection and use of data to monitor student engagement;
- The use of the students (mis)conceptions to enhance the lecture experience;
- The use of engagement and performance data to stimulate a dialogue relating to the students' well-being.

These features are not unique in their support of engineering education but have relevance across the disciplinary areas.

## 6.7 Close of Chapter Six

This chapter discussed the findings of the research against the literature. The discussion identified the successes associated with the WATS approach to assessment as well as some of the challenges, notably the deviant case (2005-06).

The following chapter indicates suggestions for further work.

## 7 Suggestions for future work

This research has responded to its original aims. It has analysed the requirements for an assessment programme and subsequently designed, developed, implemented and evaluated the new approach to assessment; the WATS approach to assessment. During the research, further lines of inquiry have emerged. These additional lines of enquiry are themed into optimising engagement, enhancing feedback and extending the use of the assessment programme.

### 7.1 Optimising engagement

This research has demonstrated that it is possible to stimulate a regular study pattern. On average, around 90% of the students submitted a response to the tasks (see Table 5-2). However, further exploration of the data, for example the time of the student submissions (see Table 5-4) and the students' unwillingness to engage in the assessment activity if it did not carry marks (see Table 5-14) raises research questions relating to the optimisation of student engagement. Such questions will help our understanding of student behaviours so that future and or similar assessment activity builds on this work.

#### 7.1.1 Establishing a submission time to reduce cramming

The submission time was originally (2002-03) set at 17:00 on the submission day. This was to keep the submission process in line with traditional means of coursework submission. It soon became apparent that students were missing the preceding lecture to concentrate on the WATS task. Subsequently the submission deadline was moved to midnight. Indeed, because the students submit their responses to a computer based tool (the *WATS Data Gatherer*), there was little reason to constrain the submission deadline according to office hours. Even with the midnight submission there were many students submitting their work close to the submission deadline. Around 10% of the students submitted their work within one hour of the deadline and around 16% of the students submitted their work within two hours of the deadline. A study exploring the optimum submission deadline to discourage cramming behaviours would be useful. For instance, it would be worth exploring the impact of a 4.00am submission deadline. Reducing cramming would give the students a better chance to engage properly in the activity and encourage a better study pattern.

### 7.1.2 Minimising the grade without compromising engagement

Formative assessment is low-stakes. The WATS approach to assessment is an example of formative assessment. However, to stimulate engagement the students are allocated a grade for their work. The maximum grade for each of the weekly tasks is around 1.5% of the overall module grade. Hence, scoring 50% on one week's tasks allows the students to take forward 0.75% to their final grade. It is disappointing that any marks are needed and that the students do not engage purely for the pleasure of learning. A situation where tutorial questions are provided with no requirement or marks for submission would not be dissimilar to the situation that stimulated the research in the first place. Indeed, as indicated, many students fed back that they would not have engaged with the tasks if they did not count towards the final grade for the module. An exploration of the minimum grade required for each sheet to ensure student response would be a useful follow-on activity for the WATS activity and also for colleagues trying to encourage participation with different forms of low-stakes formative assessment.

## 7.2 Enhancing the feedback capability and ensuring its use

Feedback is an essential component of learning and is embedded in the WATS approach to assessment. In the assessment programme, feedback is provided in a range of guises. The students receive a personalised e-mail shortly after the submission deadline and the whole group receive a full worked solution as well as an updated *WATS League Table*. Additionally teachers are able to take account of the feedback and use it to shape their upcoming lectures. Two issues have arisen as the research has progressed (see Sections 7.2.1 & 7.2.2) Responding to these issues would, it is argued, enhance the assessment experience and the students' learning.

### 7.2.1 Improvements to the feedback

The *WATS Marking Wizard* currently includes intelligent diagnostics to interrogate the students' submissions and look for common mistakes. This feature points the students to the cause of any likely errors. It would be useful to make these features more usable by the novice WATS academic user so that student feedback is enhanced. Currently these features are implemented by a WATS user manually applying Microsoft Excel logic e.g.. *IF*, *AND*, *ELSE*, etc. Depending on the tests being carried out, the logic can become complex and potentially off-putting. Hence, opportunities to enhance learning through feedback might not be exploited fully. Although the WATS wizards are currently being used by around eight

members of staff at the University, the author is not aware of any other staff members making use of the intelligent diagnostics.

The assessment programme could be usefully extended by developing linking mechanisms to common diagnostic functions via easy-to-use interface components on the *WATS Marking Wizard*. This would enhance the potential to use more intelligent diagnostics and hence provide more personalised feedback.

### 7.2.2 Actively engaging students in the feedback and the use of feedback for resubmission

The different forms of feedback provided to students were presented in Section 7.2. The feedback is prompt and personalised, and there is a facility to embed diagnostics of likely mistakes. In the years considered in this research (2002-03 to 2005-06), there was no requirement for the students to actively engage with the feedback, hence there was little evidence that the students had gained anything from receiving and reading the feedback. More recently, in work as yet unpublished, the WATS approach to assessment has offered students an opportunity to resubmit their work based on the feedback they receive. In another module (Engineering Science), the students were given a new sheet incorporating a new set of random factors along with their feedback. The students were then invited to submit a response to the follow-up task. This linked activity; task-feedback-new task, allows students to demonstrate use of the feedback. This was not the case in the Fluid Dynamics and Thermodynamics Module. In the Engineering Science module, while some students chose not to resubmit, many students did take up the opportunity. Additional research could focus on the assessment programme with the follow-up activity. Such research could include:

- establishing the merits and demerits of the alternative protocols for engaging students in the feedback; i.e. require all students to engage or leave it as a voluntary activity?
- establishing what additional learning may be taking place by giving students a chance to interact with the feedback; and
- exploration of the reasons why students choose to resubmit (or not).

## 7.3 Embedding and expanding use

This research is located in engineering. There are other instances, across the University, where the WATS approach to assessment is being used. Additional research could be developed to establish the appropriateness of use elsewhere, and also in developing the systems into the University's MLE.

### 7.3.1 Embed the WATS tools into the MLE

The ICT-based wizards used to create the random factors, collect the students' submissions, mark the students' work and provide the feedback are currently stand-alone products authored in Microsoft Excel and Visual C++. Having gone through a substantial proof of concept phase, it would be prudent to consider bringing this functionality into the university's MLE. The motivation to bring the wizards into the MLE is two-fold. First, making the wizards accessible inside the MLE immediately brings them to the attention of other academics. Raising the awareness of the WATS approach to assessment and having the tools located in the MLE is likely to increase the use of the WATS approach to assessment. This will widen the benefits of such an approach to assessment and also lead to additional functionality as the size of the user-group increases. Second, the university is currently trying to rationalise the log-in arrangements required for students to access its many computer based systems. Currently the *WATS Data Gatherer* requires an additional password and username and lives outside the MLE. Students, therefore, collect their work and discuss the WATS and module related issues within the MLE but submit their work outside the MLE. Bringing the *WATS Data Gatherer* inside the MLE would eliminate the need for multiple log-ins and enable a one-stop-shop for the assessment programme.

#### 7.3.1.1 Spreading the use

The WATS approach to assessment and the associated wizards are currently being used in other disciplinary areas at the University. Notably the approach to assessment is being used in the School of Pharmacy, the Business School and the School of Life Sciences. This additional use, i.e. outside the original context of engineering, suggests both the approach and the tools developed are transportable to other (numerically based) disciplines, and are usable by staff other than the developer.

The nature of the assessment activity suggests it could be further exploited at tertiary and secondary level education. Many engineering departments across HE are dealing with the

challenge of mathematical weakness in some of their students. The WATS approach to assessment might prove a valuable addition to mathematics education. The same is true at secondary level education. Teachers might use the assessment tools to challenge their students via student unique homework tasks and spend their time teaching and responding to student demonstrable need rather than marking the work. It is likely that development for secondary level mathematics education could be even more resource efficient than the development discussed here, due to the standardised nature of the national curriculum.



## 8 Conclusion

This chapter draws together the research and offers a concluding summary. The conclusion is sectionalised to respond to the main features of the research activity.

### 8.1 The need for this research

Teaching does not always lead to learning. Learning requires participation and active engagement from students. The high failure rate in Fluid Mechanics and Thermodynamics (2001-02) was due to a lack of regular student engagement. The lack of student engagement in this module cascaded to a series of consequences as follows:

- the students were unlikely to have appreciated or been aware of what they understood and what they didn't;
- the students may have developed a false sense of security;
- the students would not have been provided with feedback since there was little to feed back on;
- the students are unlikely to have been as well prepared for the upcoming lectures as they should have been;
- new lecture topics are likely to have been perceived as obscure since the building blocks and understanding from previous lectures and topics were not in place;
- teachers would not have seen how their students were coping with the module and hence were not able to adapt their teaching according to demonstrable need.

The cascading consequences run contrary to much of what we understand about situations and environments that stimulate and support learning.

Exploration of the Definitive Module Guide suggested that the blame could not be laid entirely with the students, as there was limited encouragement for the students to pick up their books and engage themselves in appropriate and regular study. Assessment has long been recognised as a dominant driver to engage students. In 2001-02 the assessment regime consisted of two laboratory studies and, more importantly, a phase test set towards the end of the semester. Setting the phase test towards the end of the semester did little to motivate students to practise, test themselves, solve problems or abstract their knowledge to new problems throughout the semester. Moreover, due to the large class sizes, students would not have received feedback on their phase test until it was too late to be of any real

use. The lateness of the feedback was problematic as opportunities for students to engage with, learn from and act on the feedback would have long since past.

## 8.2 The WATS development

For many students, the curriculum is determined by the assessment arrangements. In response to the issues raised in 2001-02, this research conceived, designed, developed, implemented and evaluated a new approach to assessment; an approach to assessment that is aligned with many of the principles of good teaching and assessment practice.

Conceiving an educationally effective assessment programme is possible. There is a literature surrounding educationally effective assessment that includes design advice, examples and principles of good practice. The challenge, however, is to move from inception to implementation of an assessment programme that is both educationally effective *and* resource efficient. Creating an educationally effective and resource efficient assessment experience is particularly problematic as class sizes grow and the associated teaching resource is reduced.

Themes guiding the design of the assessment programme were developed from a review of the literature. The overarching design themes identified dictated that the assessment programme shall be:

- Aligned
- Learning focused
- Resource efficient

The development, the WATS approach to assessment, responded to all three design themes and the identified supporting principles.

Following the implementation of the WATS approach to assessment, a more aligned learning environment was established. The teaching, learning outcomes and assessment are now mutually supportive of each other. Student activity is now aligned with the expectations of the teaching team and the intent set out in the Definitive Module Document. The alignment is underpinned by a learning focused assessment programme that creates low-stakes and regular student engagement with tasks that consolidate the lecture. The WATS approach to assessment provides opportunities for peer-to-peer interaction while still necessitating individual activity. Student engagement is followed by prompt feedback to both

students and teachers. Students are now able to review and use the feedback prior to engaging in the next assessment activity. Their active engagement in weekly tasks helps to consolidate the current lecture topic so as to support their understanding and confidence for the upcoming lecture topic. Further, teachers are able to use the feedback to help shape the upcoming lecture. The WATS approach to assessment provides information to teachers about their students' performance at a time when they are able to take some action to either stretch their students, when the students have demonstrated a good understanding, or re-review the topic when the students have demonstrated limited understanding. As a consequence of the development, the so-called backwash of assessment now creates positive effects for learning. Student study patterns and behaviours have improved and the assessment programme has created a focus on activities that is likely to lead to learning.

Following the proof of concept phase of the implementation (2002-03), the ICT tools developed in this research make the assessment programme a practicable, and resource-efficient, proposition. The ICT tools allow student unique, weekly assessed tasks to be set, collected and marked for large numbers of students. The number of students engaging in the WATS approach to assessment during this research programme was consistently high; 128 (2002-03), 133 (2003-04), 163 (2004-05) and 172 (2005-06). There is little to suggest that the number of students that can be appropriately challenged by the WATS approach to assessment is limited. The limits of useful application are more closely associated with alignment to the Intended Learning Outcomes, the level at which the assessment programme is applied, and the disciplinary area.

Implementation of the assessment programme allowed for its use to be evaluated against the research questions. Fundamentally, the research questions set out to establish the impact of the effect of the assessment programme on:

- student support
- student study behaviours
- student performance
- teaching and learning oriented support

Additionally there was an explicit intent to gauge the students' perception of the usefulness of the assessment programme.

The following sections conclude the findings relating to each of the research questions.

## 8.3 Responding to the research questions

### 8.3.1 Conclusions relating to the impact of the assessment programme on student support

The assessment programme was developed to respond to students failing the final module examination. A secondary yet important beneficial consequence of the research and developments has been the ability to use the WATS League Table to look for evidence of students in difficulty. Erratic submission profiles or periods of non-submission highlight students that may be struggling with non-academic issues.

Additionally, the use of weekly e-mails to both submitting and non submitting students has created another opportunity for the students to communicate with the teaching team. Some students are now responding to the 'did not submit' e-mail and are describing why they were not able to submit. In some instances the responses warranted no further action whereas in others they offered an additional insight into the students' lives and the difficulties they were facing. In such cases appropriate guidance was offered.

Highlighting students in difficulty and responding to their pastoral needs is an important endeavour. It is likely that only when the students are free from external distracting pressures and demands are they able to concentrate fully on their studies. Pastoral care is a foundation for learning and the WATS approach to assessment provides more information than was previously available.

With increasing student numbers, increasing class sizes and an attendant reduction in contact time, identifying students that are at risk and hence looking after the students' well-being is going to become an increasingly difficult task. This research and the tools created immediately allow potentially at risk students to be identified.

### 8.3.2 Conclusions relating to the impact of the assessment programme on student study behaviours

The WATS approach to assessment has, by definition, stimulated appropriate weekly student activity. The level of weekly engagement has consistently been high. Across all years exposed to the assessment programme, 89% of the students submitted a response each week. This is significant since the weekly tasks were consolidatory, related to the current lecture topic and also provided a useful opportunity to prepare students for the upcoming lecture.

Stimulating weekly engagement ensured the students were spending time-on-task and committing themselves fully to the module. Many students commented that without the assessment tasks they would not have engaged with the module. Distributing the students' effort on meaningful activity also helped to ensure that they were learning as they were going along. The students would have had an opportunity to use the revision time for revision and not, as in the case of the 2001-02 cohort, first-vision. Cramming was not now an issue.

Most students chose to submit their work on the day of the submission deadline. There was evidence on the module Discussion Forum that the students were working on the tasks during the week and not just on the day of the submission deadline. There were, however, around 10% of students submitting their responses within one hour of the midnight submission deadline. For these students, it is likely that they were working on the tasks at this time.

To a certain extent the WATS approach to assessment forced a study pattern on the students. This was noted and welcomed by many the students. For first year undergraduates, being appropriately inculcated into the transition from secondary to tertiary education was a useful feature of the assessment programme.

The research has demonstrated that much of the students' engagement has been stimulated (forced) by allocating grades for the students' responses. Student engagement has repeatedly been presented as being significant in student learning. Even the MIT student in Snyder's (1970, p. 42) review who chose to sleep over his books in the hope that "*the knowledge in the books would, by osmosis, get into his head*" is likely to recognise that learning is a '*doing activity*'. The activity stimulated here has been individual while also allowing for collaboration and dialogue between the students.

While allocating grades may motivate an orientation to a strategic approach to studies, the students will now, according to the evidence presented here, be studying more than they would otherwise. The marking structure of the assessment programme was not high stakes, and the students are still able to progress through the module while freely demonstrating misconceptions along the way. Failure on the individual assessment tasks does not signal failure on the module but rather raises an opportunity to engage with the feedback and learn from the mistakes and/or correct any misconceptions.

### 8.3.3 Conclusions relating to the impact of the assessment programme on student performance

There is a positive relationship between the students' scores in the WATS and the examination, with correlation coefficients of 0.580 (2002-03), 0.605 (2003-04), 0.697(2004-05) and 0.568 (2005-06). The relationships for the stated correlation coefficients are all statistically significant at the 5% level ( $p < 0.05$ ).

Analysis of the students' performance has shown that the implementation has had a positive effect on the students' learning. The pre-WATS mean examination score was 39.2% whereas the cohorts exposed to the WATS approach to assessment achieved mean examination scores of 47.1% (2002-03), 42.2% (2003-04), 51.6% (2004-05) and 33.5% (2005-06). In two of the four years the improvement in examination scores against the pre-WATS cohort was seen to be statistically significant ( $p < 0.05$ ).

### 8.3.4 Conclusions relating to the impact of the assessment programme on teaching and learning oriented support

The assessment programme provides data to the students that can also be used by teachers to explore their students' understanding. The nature of the data far exceeds what was previously available, and also what is likely to exist on other modules not engaging in WATS-type activity. The *WATS League Table* provides up-to-date information on individual student performance and progress as well as cohort performance relating to the various topic areas.

The performance data has the potential to make a real difference to the ongoing teaching and learning settings, since teachers can draw on it to refresh what seems to be misunderstood, or accelerate and stretch students when a topic area seems to be well understood by the students.

Such an intervention challenges notions of teacher/content centric curricula and moves further into the domain of student or learner centric teaching. Teachers less comfortable with student-centric teaching will still benefit from the use of WATS-type activity, but the impact may be reduced.

### 8.3.5 Conclusions relating to the student perception of the usefulness of the WATS approach to assessment.

This research sought the student view through questionnaires with open and closed questions, e-mail, and contributions made to the module Discussion Forum. Overall, the students report a positive experience relating to the WATS, in particular the way it 'forced' them to engage with their studies. Many students comment that without the WATS they would not have engaged as much as they did on the module.

Across the years there is considerable agreement about what is valued in the assessment programme and what is not. The students are confident the experience will help them in their examination and also believe that you can only do well in the WATS if you understand the subject. Perhaps the most worrying aspect from the WATS specific questionnaire relates to the influence of the grade. Many students report they would not engage in the activity, irrespective of what they said about learning and helping in the examination, if the work did not gain them marks. Indeed, the students also report that they like getting a mark for their efforts.

The students fed back positively about many of the core features of the WATS; e.g. they like the student uniqueness of the tasks and also the *WATS League Table*.

They exhibit some lack of trust in the automated data collection and marking process. Coding of the open responses supports the questionnaire feedback, since a recurrent theme from the students is their concern about fairness of marking. The students' view of the fairness of marking is slightly troublesome since the questions can be decoupled and the marking can also be done on working out rather than the correctness of answer.

## 8.4 Consistency of conclusions

The conclusions drawn do not relate to one cohort. They are developed from analysis of all the cohorts exposed to the assessment programme. The research design included consideration of data triangulation. In all instances (except the students' performance in the 2005-06 examination) the conclusions relate to all the cohorts. Analysis across the cohorts allows the conclusion to be tested to see if they are skewed by an atypical cohort.

## 8.5 Close of thesis

The WATS approach to assessment is arguably an example of a resource efficient and educationally effective assessment programme. The WATS approach to assessment engages students in meaningful activity and supplements the existing teaching and learning interactions. Considering the research and the benefits for teaching, student support and ultimately student learning, the WATS approach to assessment is recommended for modules that have a numerical content.



## References

- Adair, J. (1984). The Hawthorne Effect: A reconsideration of the methodological artifact. *Journal of Applied Psychology, 69*(2).
- Alltree, J. (2008). A case study of the institution-wide implementation of a managed learning environment. University of Sheffield, Sheffield.
- Anderson, L., & Krathwohl, D. (2000). Taxonomy for Learning, Teaching, and Assessing: A Revision of Bloom's Taxonomy of Educational Objectives: Allyn & Bacon.
- Angelo, T., & Cross, K. (1993). *Classroom Assessment Techniques, A handbook for college teachers* (2nd ed.). San Francisco: Jossey-Bass Publishers.
- Ashwin, P. (2006). The development of learning and teaching in higher education: The changing context. In P. Ashwin (Ed.), *Changing higher education: The development of learning and teaching*. Oxfordshire (UK): RoutledgeFalmer.
- Barnett, R. (2007). *A will to learn; being a student in an age of uncertainty*. Berkshire (UK): Society for research into higher education & open university press.
- Battles, D. (2000). The use of notecards as a technique for enhancing the quality of large introductory classes. *Journal of Geoscience Education, 48*(1), 30-32.
- Baur, M., & Gaskell, G. (2000). Qualitative researching with text, image and sound. A practical handbook. London (UK): Sage Publications Ltd.
- Bennett, S., & Nuthi, V. (2008). *Towards a properly Web 2.0 way of creating and sharing questions*. Paper presented at the 12th International Conference on Computer Assisted Assessment, Loughborough (UK).
- Berk, R. A. (1998). A humorous account of 10 multiple-choice test-item flaw that clue testwise students. *Journal on excellence in college teaching, 9*(2), 93-117.
- Biggs, J. (1987). *Study process questionnaire manual*, : Australian Council for Educational Research.
- Biggs, J. (2003). *Teaching for quality learning at university* (2nd ed.): The Society for Research into Higher Education.
- Biggs, J., & Collis, K. (1982). *Evaluating the quality of learning - the SOLO taxonomy*. New York, USA: Academic Press.
- Birol, G., Liu, S., Smith, D., & Hirsch, P. (2006). Educational modules in tissue engineering based on the How People Learn Framework. *Bioscience Education e Journal, 7*.
- Black, P., Harrison, C., Lee, C., Marshall, B., & Wiliam, D. (2008). *Assessment for Learning: Putting it into practice*. Berkshire, UK: Open University Press.
- Black, P., & Wiliam, D. (1996). Meanings and consequences: A basis for distinguishing formative and summative functions of assessment? *British Educational Research Journal, 22*(5), 537-548.
- Black, P., & Wiliam, D. (1998). Inside the Black Box: Raising standards through classroom assessment.
- Blaxter, L., Hughes, C., & Tight, M. (2006). *How to do research*. Maidenhead (UK): Open university press.
- Blichfeldt, B., & Andersen, J. (2006). Creating a wider audience for action research: Learning from case-study research. *Journal of Research Practice, 2*(1).
- Bligh, D. (1998). *What's the use of lectures?* Bristol, UK: Intellect Books.
- Bloom, B. S. (1956). Taxonomy of educational objectives: the classification of educational goals: handbook I, cognitive domain. London: Longman Group.
- Bloxham, S., & Boyd, P. (2007). *Developing effective assessment in higher education: A practical guide*. Berkshire (UK): McGraw Hill.
- Boud, D. (2000). Sustainable assessment: rethinking assessment for the learning society. *Studies in Continuing Education, 22*(2), 151-167.
- Boud, D. (2005). *Assessment and learning: contradictory or complementary?* London, UK: Kogan Page.
- Bransford, J., Brown, A., & Cocking, R. (2000). *How People Learn: Brain, Mind, Experience, and School*. Washington: National Academy Press.

- Bridge, J. (2005). A web-based tutorial system in Engineering Dynamics. Paper presented at the International Conference on Engineering Education,, Gliwice, Poland.
- Bridge, W. (2006). Non traditional learners in Higher Education. In P. Ashwin (Ed.), *Changing Higher Education: The development of teaching and learning*. Oxfordshire (UK): RoutledgeFalmer.
- Bridges, P., Cooper, A., Evanson, P., Haines, P., Jenkins, D., Scurry, D., et al. (2002). Coursework marks high, examination marks low: discuss. *Assessment & Evaluation in Higher Education*, 27(1).
- Britain, S., & Liber, O. (1999). *A framework for pedagogical evaluation of Virtual Learning Environments*: JISC Technology Applications Programme.
- Brosnan, M. (1999). Computer anxiety in students: should computer-based assessment be used at all? London: Kogan Page Limited.
- Brown, G. (2001). *Assessment: A guide for lecturers* (Vol. 3): LTSN Generic Centre.
- Brown, G., Bull, J., & Pendlebury, M. (1997). *Assessing student learning in Higher Education*. New York: Routledge.
- Brown, N., Smyth, K., & Mainka, C. (2006). *Looking for evidence of deep learning in constructively aligned online discussions*. Paper presented at the Sixth international conference of networked learning.
- Brown, S., Armstrong, S., & Thompson, G. (1998). *Motivating students*. London (UK): Staff and Educational Development Series: Kogan Page Limited.
- Brown, S., Race, P., & Rust, C. (2005). Using and experiencing assessment. In P. Knight (Ed.), *Assessment for learning in higher education*. Oxfordshire (UK): RoutledgeFalmer.
- Bryan, N., & Glasfurd-Brown. (2005). *The SPRInTA Project: Supporting student assessment through a portal*. Paper presented at the 9th International Computer Assisted Assessment Conference, Loughborough (UK).
- Bull, J., & McKenna, C. (2004). *Blueprint for Computer Assisted Assessment*. London UK: Routledge Falmer.
- Bullen, P., & Russell, M. (2007). *A blended learning approach to teaching first year engineering degree students*. Paper presented at the 10th International Conference of Engineering Education, Coimbra, Portugal.
- Cahyadi, V. (2008). *No more 'plug and chug'*. New York, USA: Routledge.
- Carbonne, E. (1998). *Teaching large classes; tools and strategies*. London (UK): Sage Publications Limited.
- Carless, D. (2006). Differing perceptions in the feedback process. *Studies in Higher Education*, 31(2), 219-233.
- Carless, D. (2007). Learning-oriented assessment: conceptual bases and practical implications. *Innovations in Education and Teaching International*, 44(1), 57-66.
- Carneson, J., DelpierreG, & Masters, K. (1996). *Designing and Managing Multiple Choice Questions*. Cape Town.
- Cartelli, A., Stansfield, M., Connolly, T., Jimoyiannis, A., Magalhaes, H., & Maillet, K. (2008). Towards the development of a new model for best practice and knowledge construction in virtual campuses. *Journal of Information Technology Education*, 7.
- Carter, C. (1998). Assessment: Shifting the responsibility. *The Journal of secondary gifted education*, 9(2), 68-75.
- Chickering, A., & Ehrmann, S. (1996). Implementing the Seven Principles: Technology as Lever. *AAHE Bulletin*, 3-6.
- Chickering, A., & Gamson, Z. (1987). Seven principles for good practice in undergraduate education. *American Association of Higher Education Bulletin*, 3-7.
- Clark, A. (1999). *Evaluation research: An introduction to principles, methods and practice*. London (UK): Sage.
- Combes, A. (2004). Attracting young people into the engineering profession,. *British Journal of Engineering Education*, 4(1), 33-39.

- Connely, L. (2004). Assertion-reason assessment in formative and summative tests: Results from two graduate case studies. In R. Ottewill, L. Borredon, L. Falque, B. Macfarlane & A. Wall (Eds.), *Educational Innovation in Economics and Business VIII: Pedagogy, Technology and Innovation*, (pp. 359-378).
- Conole, G., & Warburton, B. (2005). A review of computer-assisted assessment. *ALT-J, Research in Learning Technology*, 13(1), 17-31.
- Cordray, C., & Harris, T., Klein, S. (2009). A research synthesis of the effectiveness, replicability and generability of the VaNTH challenge-based instructional modules in bioengineering. *Journal of Engineering Education*, 98(4).
- Crawley, E., Malmqvist, J., Ostlund, S., & Brodeur, D. (2007). *Rethinking Engineering Education: The CDIO Approach*. New York, USA: Springer Science + Business Media.
- Creswell, J. (1994). *Research design: qualitative and quantitative approaches*. London (UK): Sage.
- Crosling, G. (2008). *Facilitating student Success; Disciplines and curriculum development*. London: Routledge.
- Dangel, H., & Wang, C. (2008). Student response systems in Higher Education: Moving beyond linear teaching and surface learning. *Journal of Educational Technology Development and Exchange*, 1(1).
- Daugherty, R., & Ecclestone, K. (2006). Constructing Assessment for learning in the UK policy environment. In J. Gardner (Ed.), *Assessment and Learning*. London, UK: Sage.
- Davies, P. (2001). Computer Aided Assessment MUST be more than multiple-choice tests for it to be academically credible? Paper presented at the 5th International CAA Conference, Loughborough, UK.
- Davies, P. (2002). *There's no confidence in multiple choice testing*. Paper presented at the 5th International CAA Conference, Loughborough UK.
- de la Harpe, B., Radloff, A., & Parker, L. (1997). *Time spent working and studying in the first year: What do students tell us?* Paper presented at the Learning Through Teaching: 6th Annual Teaching Learning Forum: Monash University, Perth, Australia.
- Denzin, N. (1970). *Sociological methods. A sourcebook*. Chicago (USA): Aldine Publishing Company.
- Dick, B. (2003). Why action research? Retrieved 26 March 2009, <http://www.scu.edu.au/schools/gcm/ar/whyar.html>
- Díez, D., Díaz, P., Aedo, I., & Fernández, C. (2008). *Automating the assessment process to improve the informative feedback*. Paper presented at the 38th Annual Frontiers in Education Conference, Saratoga Springs, USA.
- Duncan, N. (2007). Feed-forward': improving students' use of tutors' comments. *Assessment & Evaluation in Higher Education*, 32(3).
- Ebel, R., & Frisbie, D. (1991). *Essentials of Educational Measurement*, . New Jersey (USA): Prentice Hall.
- Echternacht, G. (1972). The use of confidence testing in objective tests. *Review of Educational Research*, 42(2), 217-236.
- Ellis, E., & Worthington, L. (1994). Research synthesis on effective teaching principles and the design of quality tools for educators.
- Entwistle, N. (1998). Motivation and approaches to learning: Motivating and conceptions of teaching. In S. Brown, S. Armstrong, Thompson & G (Eds.), *Motivating students*. London (UK): Kogan Page Limited.
- Falchikov, N. (2005). Improving feedback to and from students. In P. Knight (Ed.), *Assessment for learning in Higher Education*. London (UK): RoutledgeFalmer.
- Fallows, S., & Chandramohan, C. (2001). Multiple approaches to assessment: reflections on use of tutor, peer and self-assessment. *Teaching in Higher Education*, 6(2), 229-246.
- Fink, L. D. (1999). Fink's five principles of course design. 2008
- Fleming, N. (2001). *Teaching and Learning Styles: VARK Strategies*.

- Forbes, D. A., & Spence, J. (1991). *An experiment in assessment for a large group*. Chichester, UK: Ellis Horwood Limited.
- France, L., & Beaty, L. (1998). Layers of motivation: Individual orientations and contextual influences. In S. Brown, S. Armstrong & G. Thompson (Eds.), *Motivating students: Staff and Educational Development Association*.
- Frean, A. (2006). University teachers: 'could try harder'. *The Times* (24th August), p. 26.
- Gagne, R., Briggs, L., & Wagner, W. (1992). *Principles of Instructional Design*. Orlando, USA: Harecourt Brace Jovanovich.
- Gardner, H. (1993). *Frames of mind: The theory of multiple intelligences*. New York, USA: Basic books.
- Gibbs, G. (1999). Improving teaching, learning and assessment. *Journal of Geography in Higher Education*, 23(2), 123-132.
- Gibbs, G., Habeshaw, T., & Habeshaw, S. (1992). *53 Interesting ways to teach large classes: Making the best of a bad job*. Bristol (UK): Technical and Educational Services Ltd.
- Gibbs, G., & Jenkins, A. (1992). Teaching large classes in higher education, How to maintain quality with reduced resources. London (UK): Kogan Page Limited.
- Gibbs, G., & Simpson, C. (2004). Conditions under which assessment supports students' learning. *Learning and Teaching in Higher Education*, 1, 8.
- Gipps, C., & Murphy, P. (1999). *A fair test? Assessment, achievement and equity*. Buckinghamshire (UK): Open University Press.
- Glaser, B., & Strauss, A. (1967). *Discovery of Grounded Theory: Strategies for qualitative research*. New York (USA): Aldine De Gruyter.
- Glover, C., & Brown, E. (2006). Written feedback for students: too much, too detailed or too incomprehensible to be effective? *Bioscience Education e-journal Journal of the Higher Education Academy Bioscience Subject Centre*.
- Gosling, D. (2007). Supporting student learning. In H. Fry, S. Ketteridge & S. Marshall (Eds.), *A handbook for teaching and learning in Higher Education: Enhancing academic practice*. London, UK: RoutledgeFalmer.
- Greenback, P. (2003). The role of values in educational research: the case for reflexivity. *British Educational Research Journal*, 29(6), 791-801.
- Greenbank, P. (2003). The role of values in educational research: the case for reflexivity. *British Educational Research Journal*, 29(6).
- Guba, E. (1981). Criteria for assessing the trustworthiness of naturalistic inquiries. *Educational Technology Research and Development*, 29(2), 75-91.
- Guba, E., & Lincoln, Y. (2000). Competing paradigms in qualitative research. In N. Denzin & Y. Lincoln (Eds.), *Handbook of qualitative research*. California (USA): Sage Publications Inc.
- Haigh, M. (2007). Sustaining learning through assessment: an evaluation of the value of a weekly class quiz', , 32:4, 454. *Assessment & Evaluation in Higher Education*, 32(4), 457 - 474.
- Hakel, M. (1998). *Beyond multiple choice: Evaluating alternatives to traditional testing for selection* London (UK): Lawrence Erlbaum Associates.
- Handley, K., Szwelnik, A., Ujma, D., Lawrence, L., Millard, J., & Price, M. (2007). *When less is more: Students' experiences of assessment feedback*. Paper presented at the Higher Education Academy, York, UK.
- Harlen, W., & James, M. (1997). Assessment and learning: differences and relationships between formative and summative assessment. *Assessment in Education: Principles, Policy & Practice*, 4(3), 365-379.
- Harrison, M. (2008). *Mathematics Support for Engineering Undergraduates*. Paper presented at the International Conference on Engineering Education, Pecs, Hungary.
- Hartley, R., & Collins-Brown, E. (1999). Effective pedagogies for managing collaborative learning in on-line learning environments. *Educational Technology Society*, 2(2).
- Hasselgren, B. (1981). *Ways of apprehending children at play: A study of pre-school student teachers' development*. Retrieved July 1 2008, 2008

- HEFCE. (1997). Information technology assisted teaching and learning in UK Higher Education
- HEFCE. (2005). Learning and teaching: National Student Survey. Retrieved 20 October, 2008
- Herrington, J., & Standen, P. (2000). Moving from an instructivist to a constructivist multimedia learning environment. *Journal of Educational Multimedia and Hypermedia*, 9(3), 195–205.
- HESA. (2008). Students and qualifiers data tables - [http://www.hesa.ac.uk/index.php?option=com\\_datatables&Itemid=121&task=show\\_category&catdex=3#institution](http://www.hesa.ac.uk/index.php?option=com_datatables&Itemid=121&task=show_category&catdex=3#institution). Retrieved 20 November 2009, 2009
- Heywood, J. (2000). Assessment in Higher Education: Student Learning, Teaching, Programmes and Institutions.
- Higgins, R., Hartley, P., & Skelton, A. (2001). Getting the message across: the problem of communicating assessment feedback. *Teaching in Higher Education*, 6(2), 269-274.
- Hoffman, M. (2005). *An engineering model of learning*. Paper presented at the 35th Annual Frontiers in Education Conference, Indianapolis (USA).
- Honey, P., & Mumford, A. (1992). *The manual of learning styles*.
- Hornby, W. (2005). Dogs, Stars, Rolls Royce's and old Double-Decker Buses: efficiency and effectiveness in assessment. Paper presented at the Reflections on assessment.
- Howe, M. (1987). Using cognitive psychology to help students learn how to learn. In J. Richardson, M. Eysenck & D. Piper (Eds.), *Student learning: research in education and cognitive psychology*. Milton Keynes: Society for Research into Higher Education and the Open University Press.
- Hughes, I., & Large, B. (1993). Staff and peer group assessment of oral communication skills. *Studies in Higher Education*, 18, 379-386.
- Huxam, M. (2007). Fast and effective feedback: are model answers the answer? *Assessment & Evaluation in Higher Education*, 32(6), 601 - 611.
- Isaksson, S. (2007). Assess as you go: the effect of continuous assessment on student learning during a short course in archaeology', *Assessment & Evaluation in Higher Education*, 1 - 9. *Assessment & Evaluation in Higher Education*, 33(1).
- Jarvis, P. (1999). The practitioner-researcher: Developing theory from practice. California (USA): Jossey-Bass.
- Jenkins, M., & Hanson, J. (2003). E.Learning series; A Guide for Senior Managers: Learning and Teaching Support Network – Generic Centre.
- Jick, T. (1979). Mixing Qualitative and Quantitative Methods: Triangulation in Action. *Administrative Science Quarterly: Qualitative Methodology*, 24(4), 602-611.
- Jones, C. (2004). Quantitative and Qualitative research; Conflicting paradigms or perfect partners. Paper presented at the Networked Learning, Lancaster, UK.
- Karweit, N. (1983). *Time-on-task. A research report*. Baltimore (USA): Centre for social organisation of schools.
- Kemp, J. E., Morrison, G. R., & Ross, S. M. (1994). *Designing effective instruction*. New York, USA: Merrill.
- Khan, K. S., Davies, D. A., & Gupta, J. K. (2001). Formative self-assessment using multiple true-false questions on the internet: Feedback according to confidence about correct knowledge. *Medical Teacher*, 23(2), 158-163.
- Kimble, G. (1967). *Foundations of Conditioning and Learning*. New York (USA): Appleton Century Crofts.
- King, W., & Gray, G. F. (1991). *Peer marking of student reports*. Chichester, UK: Ellis Horwood Limited.
- Klein, S. (2006). *Using a study of skin to teach stress and strain in high school physics, anatomy, physiology and Engineering*. Paper presented at the 9th International Conference of Engineering Education., San Juan, Porto Rico.
- Knight, P. (2001). *A Briefing on Key Concepts. Formative and summative, criterion & norm-referenced assessment*. The Learning and Teaching Support Network - Generic Centre

- Kolb, D. (2003). *Experiential Learning: experience as the source of learning and development*. New Jersey (USA): Prentice-Hall.
- Kuhn, T. (1962). *The structure of scientific revolutions*. Chicago (USA): University of Chicago Press.
- Laurillard, D. (2002). *Rethinking university teaching: A Conversational Framework for the effective use of learning technologies*. London: RoutledgeFalmer.
- Laws, E. (2005). *Promoting learning using a virtual learning environment*. Paper presented at the 8th International Conference on Engineering Education, Gliwice, Poland.
- Leedy, P., & Ormrod, J. (2005). *Practical research: Planning and design*. New Jersey (USA): Pearson Education Inc.
- Light, G., & Cox, R. (2001). *Learning and teaching in higher education*. London: PCP Publishing.
- Lilley, M., & Barker, T. (2007). Students' perceived usefulness of formative feedback for a computer-adaptive test. *The Electronic Journal of e-Learning*, 5(1), 31-38.
- Lines, D., & Gammie, E. (2004). Assessment methods report, Education Committee of the International Federation of Accountants. [http://www.ifac.org/Education/downloads/Assessment\\_Methods\\_Report.pdf](http://www.ifac.org/Education/downloads/Assessment_Methods_Report.pdf) Retrieved March 1st, 2008
- Marton, F., & Saljo, R. (1984). *Approaches to learning*. Edinburgh: Scottish Academic Press.
- McAllister, G., & Alexander, S. (2007). Key aspects of teaching and learning in information and computer sciences In H. Fry, S. Ketteridge & S. Marshall (Eds.), *A handbook for teaching and learning in Higher Education; Enhancing academic practice*. Oxon (UK): RoutledgeFalmer.
- McAlpine, L. (2004). Designing learning as well as teaching. *Active Learning in Higher Education*, 5(2).
- McAlpine, M. (2002). *Principles of assessment*. Luton, UK. (CAA centre)
- McDowell, L., & Sambell, K. (1999). *The experience of innovative assessment: student perspectives.*: Open University Press.
- McDowell, L., Sambell, K., Bazin, V., Penlington, R. W., D, Wickes, H., & Smailes, J. (2006). *Assessment for learning: Current practice exemplars from the Centre for Excellence in Teaching and Learning in Assessment for Learning*.
- Mentkowski, M., & Associates, a. (2000). *Learning that lasts: Integrating Learning, Development, and Performance in College and Beyond*. California: Johnson Bas.
- Messick, S. (1999). *Assessment in higher education: issues of access, quality, student development and public policy*. New Jersey (USA): Laurence Erlbaum Associates.
- Miller, C., & Parlett, M. (1974). *Up the mark: A study of the examination game*: Society for Research into Higher Education.
- Molenda, M. (2003). In search of the elusive ADDIE model. *Performance Improvement*, 42(5).
- Moore, N. (2006). *How to do research. A practical guide to designing and managing research projects*. London: Facet Publishing.
- Mullins, J. (2007). *Management and organisation behaviour*. Essex (UK): Pearson.
- Nicol, D. (2007). *Principles of good assessment and feedback: Theory and practice*. Paper presented at the Assessment design for learner responsibility, Reap On-Line.
- Nicol, D., & Macfarlane-Dick, D. (2006). Formative assessment and self-regulated learning: a model and seven principles of good feedback practice. *Studies in Higher Education*, 31(2), 199-218.
- Nicol, D., & Milligan, C. (2006). Rethinking technology-supported assessment in terms of the seven principles of good feedback practice. London: Taylor and Francis Group Ltd.
- Nortcliffe, A. (2005). *How can Blackboard assist in assessment and facilitation of knowledge exchange?* Paper presented at the 8th International Conference on Engineering Education, Gliwice, Poland.
- Novak, G., Gavrin, A., Anderson, W., & Patterson, E. (1999). *Just-in-time teaching: Blending active learning with web technology*. Addison-Wesley.

- OConnell, B., & OCinneide, B. P. (2005). *Design of an automated assessment system to support student retention*. Paper presented at the 8th International Conference on Engineering Education, Gliwice, Poland.
- Orsmond, P., Merry, S., & Reiling. (2000). The use of student derived marking criteria in peer and self-assessment. *Assessment & Evaluation in Higher Education*, 25(1), 23-38.
- Pask, G. (1976). *Conversation Theory: Applications in Education and Epistemology*: Elsevier Science Ltd.
- Perry, W. (1970). *Forms of intellectual and ethical development in the college years; a scheme*: Holt, Rinehart and Winston Inc.
- Pettit, J., & Mason, R. (2007). Virtual space, real learning: an introduction to VLE's. In H. Fry, S. Ketteridge & S. Marshall (Eds.), *A handbook for teaching and learning in Higher Education; Enhancing academic practice* (pp. 148-161). Oxon, UK: RoutledgeFalmer.
- Plants, H. L., Dean, R. K., Sears, J. T., & Venable, W. S. (1980). A taxonomy of problem-solving activities and its implications for teaching. In J. L. Lubkin (Ed.), *The Teaching of Elementary Problem-Solving in Engineering and Related Fields*. Washington: American Society of Engineering Education.
- Poulos, A., & Mahony, M. (2007). Effectiveness of feedback: the students' perspective. *Assessment & Evaluation in Higher Education*, 33(2), 143-154.
- Prince, M., & Felder, R. (2006). Inductive teaching and learning methods: Definitions, comparisons and research bases. *Journal of Engineering Education*, 95(2), 123-138.
- QAA. (2006). Code of practice for the assurance of academic quality and standards in higher education, *Section 6: Assessment of students* (Vol. Second edition).
- QAA. (2007). Integrative assessment: Balancing assessment of and for learning: Guide number 2, *Enhancing Practice* (Vol. 2).
- QMP. (2007). Question Mark Perception : The comprehensive assessment management system to author, schedule, deliver and report on surveys, quizzes, tests and exams. Retrieved 20 October, 2008
- Race, P. (1998). *Teaching: Creating a thirst for learning*. London: Staff and Educational Development Series: Kogan Page Limited.
- Race, P. (2001). *The lecturer's toolkit: A practical guide to learning, teaching and assessment*. London, UK: Kogan Page Ltd.
- Race, P. (2005a). *Making learning happen: A guide for post compulsory education*. London: Sage.
- Race, P. (2005b). What has assessment done for and to us? In P. Knight (Ed.), *Assessment for learning in Higher Education*. Oxon (UK): RoutledgeFalmer.
- Ramsden, P. (1994). *Learning to Teach in Higher Education*. London: Routledge.
- Reynolds, J. (2004). Evaluation of a zero tolerance assessment strategy for incorporating health and safety into an undergraduate Civil Engineering course.
- Ricketts, C., & Wilks, S. J. (2002). Improving Student Performance Through Computer-based Assessment: insights from recent research. *Assessment & Evaluation in Higher Education*, 27(5), 475-479.
- Robson, C. (2002). *Real world research*. Oxford (UK): Blackwell Publishers Ltd.
- Rolfe, I. M., J. (1995). Formative assessment: how am I doing. *The Lancet*, 345.
- Rowntree, D. (1977). *Assessing Students: How Shall We Know Them?* : Harper & Row.
- Russell, M., & Probert, S. D. (2004). FDiff3: a finite-difference solver for facilitating understanding of heat conduction and numerical analysis. 79(4), 443-456.
- Russell, M., & Surendran. (2001). Influence of active heat sinks on fabric thermal storage in building mass. *Applied Energy*, 70(1), 17-33.
- Russell, M., & Surendran, P. N. (2000). Use of computational fluid dynamics to aid studies of room air distribution: A review of some recent work. *Building Services Engineering Research and Technology*, 21(4).
- Russell, M., Surendran, P. N., & Probert, S. D. (2002). Quantifying acceptable mesh dependencies for computational investigations of airflows within rooms. *Applied Energy*, 72(1).

- Russell, M. B. (2005). *Assessing-to-Learn; Enriching the assessment process*. Paper presented at the 8th International Conference on Engineering Education, Gliwice, Poland.
- Russell, M. B. (2006). Preliminary explorations into Just-in-Time-Teaching. *Journal for the enhancement of teaching and learning*, 3(2).
- Russell, M. B. (2008). *Using an electronic voting system to enhance learning and teaching*. Paper presented at the Innovation, Good Practice and Research in Engineering Education, Loughborough, UK.
- Rust, C. (2001). *A briefing on assessment of large groups*. The Learning and Teaching Support Network – Generic Centre.
- Rust, C. (2002). The impact of assessment on student learning; How can the research literature practically help to inform departmental assessment strategies and learner-centred practices? *Active Learning in Higher Education*, 3(2), 145–158.
- Ryan, A., & Greguras, G. (1998). Life is not multiple choice: Reactions to the alternatives. In M. Hakel (Ed.), *Multiple Choice: Evaluating alternatives to traditional selection for testing* (pp. 183-202). Mahwah, NJ: Lawrence Erlbaum Associates.
- Sadler, R. (1998). Formative Assessment: revisiting the territory. *Assessment in Education*, 5(1), 77-84.
- Sam, H., K , & Othman, A. a. N., Z. (2005). Computer self-efficacy, computer anxiety, and attitudes toward the Internet: A study among Undergraduates in Unimas. *Educational Technology & Society*,, 8(4), 205-219.
- Sevim, H. (2005). *A case study of retention of freshman engineering students*. Paper presented at the International conference on Engineering Education, Gliwice, Poland.
- Shindler, J. (2008). Examining the use of competition in the classroom. *Transformative Classroom Management*.  
<http://www.calstatela.edu/faculty/jshindl/cm/Chapter20competition.htm> Retrieved 2008, 1 July 2008
- Simkins, S., & Maier, M. (2004). Using just-in-time teaching techniques in the principles of economics course. *Social Science Computer Review*, 22(4).
- Smailes, J. (2003). *Strategies for engaging students in computer based assessments - stage 1, taking stock*. Paper presented at the International Computer Assisted Assessment Conference, Loughborough, UK.
- Smailes, J., & Russell, M. B. (2004). Forcing the learning via computer assisted regular assessments: Collaborative reflections from Business and Engineering. Paper presented at the Business Education Support Team (BEST), Edinburgh (UK).
- Smaill, C. (2005). The Implementation and Evaluation of OASIS: A Web-Based Learning and Assessment Tool for Large Classes. *IEEE Transactions on Education*, 48(4), 658-663.
- Snyder, B. (1970). *The Hidden Curriculum*: Alfred A. Knopf Inc.
- Tait, H., & Entwistle, N. (1996). Identifying students at risk through ineffective study strategies. *Higher Education*, 31, 97-116.
- Taras, M. (2001). The use of tutor feedback and student self-assessment in summative assessment tasks: Towards transparency for students and for tutors. *Assessment & Evaluation in Higher Education*, 26(6), 605-614.
- Thoennessen, M., & Harrison, M. J. (1996). Computer-assisted assignments in a large physics class. *Computers & Education*, 27(2), 141-147.
- Thomas, L. (2008). *Learning and teaching strategies to promote student retention*. New York, USA: Routledge.
- Thomas, L., Quinn, J., Slack, K., & Cassy, L. (2002). *Student services: Effective approaches to retaining students in higher education*. Staffordshire, UK: Staffordshire University.
- Trotter, E. (2006). Student perceptions of continuous summative assessment. *Assessment & Evaluation in Higher Education*, 31(5).
- Turner-Bisset, R. (2001). *Expert teaching; Knowledge and pedagogy to lead the profession*. London (UK): David Fulton Publishers.
- Unistats. (2007). Database of National Student Survey results. Retrieved 20 October, 2008



- Wakefield, R. (2007). Principles of assessment. In H. Fry, S. Ketteridge & S. Marshall (Eds.), *A handbook for teaching and learning in Higher Education: Enhancing academic practice*. London (UK).
- Wakeford, R. (2007). Principles of student assessment. In H. Fry, S. Ketteridge & S. Marshall (Eds.), *A handbook for teaching & learning in higher education: Enhancing academic practice*. London (UK): RoutledgeFalmer.
- Waller, A. (2006). *Fish is fish: learning to see the sea*. Paper presented at the 36th Annual Frontiers in Education Conference.
- Wang, T. (2007). What strategies are effective for formative assessment in an e-learning environment? *Journal of Computer Assisted Learning*, 23(3), 171-186.
- Warburton, W. C., G. (2003). *CAA in UK HEIs: The state of the art*. Paper presented at the 7th International CAA Conference, Loughborough (UK).
- Weber. (1990). Basic content analysis (Qualitative applications in the Social Sciences). London (UK): Sage Publications Limited.
- Weston-Manor-Group. (2007). Assessment Standards : A manifesto for change. Retrieved 20 October 2008, from <http://www.business.brookes.ac.uk/learningandteaching/aske/Manifesto%20final.pdf>
- Williams, J. (2006). Assertion-reason multiple-choice testing as a tool for deep learning: a qualitative analysis. *Assessment & Evaluation in Higher Education*, 31(3), 287-301.
- Wisker, G. B., S. (1996). *Enabling student learning: Systems and strategies*. London (UK): Kogan Page.
- Yorke, M. (1999). Leaving early: Undergraduate non-completion in Higher Education. London (UK): Falmer Press.
- Yorke, M. (2003). Formative Assessment in Higher Education: Moves Towards Theory and the Enhancement of Pedagogic Practice. *Higher Education*, 45(4), 477-501.
- Yorke, M., & Longden, B. (2007). *The first year experience of higher education in the UK*. York (UK): The Higher Education Academy.

# Appendix A. The Definitive Module Document

The Definitive Module Document – Fluid Mechanics and Thermodynamics

Module Code: 1AAD0014	<b>Title of Module</b> <i>Full Title:</i> Fluid Mechanics & Thermodynamics <i>Short Title:</i> Fluids & Thermo
Version: 1 Level / ECTS Level: 1	<b>Credit Points:</b> 15
6. Home Department: AAD	
7. Departments(s) contributing to teaching	
9. Module Aims: * be introduced to fundamental concepts and definitions in Fluid Mechanics and Thermodynamics  * understand the application of the principles of Mechanics to Fluids  * be introduced to the first law of Thermodynamics and associated processes	
10. Learning Outcomes 10a. Learning Outcomes: Knowledge and Understanding: * identify the properties of liquids and gases * identify thermodynamic systems and processes  10b. Learning Outcomes: Skills and Attributes: * apply Fluid Mechanics principles to the analysis of fluid systems * analyse Fluid Mechanics problems using dimensional analysis * apply the first law of Thermodynamics to the analysis of open and closed systems * apply the perfect gas concept to simple gaseous systems	
11. Module Content 11a Module Content: Properties of liquids and gases, Gauge and absolute pressure. Hydrostatic principles, manometry, forces on immersed surfaces. Definition of types of fluid flow.  The mass conservation principle. The Euler-Bernoulli equation. Application of Bernoulli's equation to pipeline problems with energy losses and flow measurement. Momentum equation for steady flow. Dimensional analysis, Buckingham's method, non-dimensional coefficients.  The concept of a thermodynamic system, open and closed. Thermodynamic processes. Zeroth Law and concept of temperature. Thermodynamic work and heat, their equivalence and energy transfer. First law of thermodynamics, definition of internal energy and enthalpy. The specific heat capacities of perfect gases and their relevance to isentropic processes.  11b. Further details on how the learning outcomes of the module will be achieved: This module introduces students to the fundamentals of fluid flow and thermodynamics and	

provides a basis for higher level modules in Aerothermodynamics, Vehicle Aerodynamics and Thermofluid Mechanics.

Lectures and tutorials are accompanied by laboratory sessions in fluid mechanics and thermodynamics.

Assessment is through laboratory reports, written coursework and an examination.

12. Language of Delivery:  
English

13. Language of Assessment:  
English

14. Assessment Details (Academic):

Coursework: 30

Exam: 70

Other: Typically, assessment will consist of--

- Written coursework 15%
- Two laboratory practical reports 15%
- One 3-hour end of course unseen examination 70%

Overall pass required, subject to a maximum grade E2 if not both coursework and examination are passed

15. Locations(s):  
UH HATFIELD

16. Pre and Co-Requisite:  
Pre-Requisite  
Co-Req  
Prohibited

17. Subject Board of Examiner/s:  
AERO/CIVIL/MECH L1 COMMON

18. Comments

## Appendix B. WATS 1-11

# Fluid Mechanics and Thermodynamics

## Weekly Assessed Tutorial Sheet 1 (WATS 1)

### TUTOR SHEET – Data used in the Worked Solution

**Q1.** A piezometric tube is used to collect data at a particular location in a pipe line. Calculate –

- i) the height of the fluid, ( $m$ ), in the piezometric tube if the fluid has a density of  $1391 \text{ kg/m}^3$  and the pressure is somehow known to be  $121426 \text{ Pa}$ . **(1 mark)**
- ii) the pressure of the fluid, ( $Pa$ ), at the location of the piezometric tube, if the fluid has a relative density of  $0.59$  and the height of fluid in the tube is  $0.62 \text{ m}$ . **(1 mark)**
- iii) the specific gravity of the fluid if the pressure is known to be  $1.87 \text{ Bar}$  and the height of the fluid in the tube was measured at  $470 \text{ mm}$ . **(1 mark)**

**Q2.**  $249$  litres of red a fluid, relative density =  $0.70$ , and  $133$  litres of blue fluid of density  $2492 \text{ kg/m}^3$ , are simultaneously tipped into a rectangular based tank. Assuming that the properties of the fluids are such that they are immiscible (i.e. they don't mix), and that the tank's base dimensions are  $1.80 \text{ m} \times 1.54\text{m}$  calculate ;

- i) the mass of the red fluid ( $kg$ ) **(1 mark)**
- ii) the mass of the blue fluid ( $kg$ ) **(1 mark)**
- iii) the pressure gradient in the red fluid ( $Pa/m$ ) **(1 mark)**
- iv) the pressure gradient in the blue fluid. ( $Pa/m$ ) **(1 mark)**
- v) the pressure difference, ( $Pa$ ), between a point located at  $31 \%$  of the depth of the top fluid and another point at a depth of  $35 \%$  of the bottom fluid. Taking account of the depths you need to do this calculation as  $P_{\text{top}} - P_{\text{bottom}}$  **(2 marks)**

Note: For all questions you may assume that the acceleration due to gravity ( $g$ ) =  $9.81\text{m/s}^2$  and that atmospheric pressure is equal to  $1.01325 \text{ Bar}$

# Fluid Mechanics and Thermodynamics

## Weekly Assessed Tutorial Sheet 2 (WATS 2)

### TUTOR SHEET – Data used in the Worked Solution

**Q1.** i) A rectangular door in the side of a fluid filled tank is 0.50 m wide and 4.80 m high. If the top edge of the door is 3.10 m below the fluids free surface and the fluid has a density of  $850 \text{ kg/m}^3$  calculate

i) the total force on the door (kN) **(1 mark)**

ii) the position of the line of action (**below** the free surface) (m). **(1 mark)**

**Q2.** Assuming now that the tank has been drained of the original fluid and that another fluid of relative density 0.89 has partially filled the tank so that its free surface is 0.52 m below the top of the door. Calculate

i) the total force now acting on the door (kN) **(1 mark)**

ii) the position of the line of action (**below** the free surface) (m). **(1 mark)**

iii) If the door is now turned through  $90^\circ$  (i.e. it is still in the side of the tank but its width and height have now been transposed) at what **depth** would the top edge of the door have to be for the resulting force to be the same as that calculated for Q2 i)? (m) **(1 mark)**

iv) Assuming now that the door has been moved so that it is located in the horizontal floor of the tank. Calculate the required **depth** of fluid in the tank if the door is only to be exposed to the same force as calculated in Q2 i) (m). **(2 marks)**

**Q3.** Please provide one hint or tip that would be useful to help future students tackle successfully the problems on this sheet. You will be awarded **3 bonus marks** for providing a sensible hint or tip.

# Fluid Mechanics and Thermodynamics

## Weekly Assessed Tutorial Sheet 3 (WATS 3)

### TUTOR SHEET – Data used in the Worked Solution

**Q1.** A 5cm diameter pipe conveying a fluid of relative density 0.61 has a downward slope of 1 in 27. At point 'A' in the pipe the static (gauge) pressure is  $55 \text{ kN/m}^2$ . Calculate –

- i) the static gauge pressure in the pipe 41 m downstream of point A. ( $\text{kN/m}^2$ ) **2 marks**
- ii) the static gauge pressure in the pipe 77 m upstream of point A. ( $\text{kN/m}^2$ ) **2 marks**

**Q2.** A siphon consists of a 9.50cm diameter pipe rising directly from an open tank to a height of 3.30m above the fluids free surface. At this point, 'A', the pipe bends downwards and continues to drop until point B. Point B being the siphons discharge 9.20m below point A. Assuming the fluid has a relative density of 0.61 calculate –

- i) the velocity of the fluid in the pipe. (m/s) **2 marks**
- ii) the volumetric fluid flow rate through the siphon ( $\text{m}^3/\text{s}$ ) **1 mark**
- iii) the mass flow rate of fluid through the siphon. (kg/s) **1 mark**

Assume now that the length A→B changes but the height of A does not change with respect to the free surface. Assume also that that the head at point A should not fall below **0.90 m of water** at  $4^\circ\text{C}$ . Calculate -

- iv) the new volumetric fluid flow rate through the siphon ( $\text{m}^3/\text{s}$ ) **3 marks**
- v) the new length to A→B (m) **2 marks**

Take the atmospheric pressure as being equivalent to 10.31m head of water at  $4^\circ\text{C}$ . You may assume that the density of water at  $4^\circ\text{C}$  is  $1000 \text{ kg/m}^3$  and that the acceleration due to gravity is  $9.81 \text{ m/s}^2$ .  $\text{Pi} = 3.142$ .

# Fluid Mechanics and Thermodynamics

## Weekly Assessed Tutorial Sheet 4 (WATS 4)

### TUTOR SHEET – Data used in the Worked Solution

**Q1.** A system executes a cycle which is made up of four processes. The heat and work transfers that take place in the first three processes are:

Process 1	$Q_1 = 1.60 \text{ kJ}$ and $W_1 = -58.60 \text{ kJ}$
Process 2	$Q_2 = 70.60 \text{ kJ}$ and $W_2 = -11.10 \text{ kJ}$
Process 3	$Q_3 = -23.90 \text{ kJ}$ and $W_3 = 59.90 \text{ kJ}$

If the work transfer during the fourth process i.e.  $W_4$ , is  $78.20 \text{ kJ}$  determine the corresponding heat transfer  $Q_4$  (kJ) **(1 mark)**

**Q2.** Using the Thermodynamic and Transport Properties of Fluids -

- i) Find the specific enthalpy (kJ/kg) of saturated water in the liquid phase at  $40^\circ\text{C}$  **(1 mark)**
- ii) Find the specific enthalpy (kJ/kg) of saturated water in the vapour phase at  $26^\circ\text{C}$  **(1 mark)**
- iii) Find the specific enthalpy change (kJ/kg) between saturated water vapour and saturated water liquid when it is at  $34^\circ\text{C}$  **(1 mark)**

**Q3**  $0.30 \text{ kg}$  of water enter a device as a saturated vapour at  $0.20 \text{ Bar}$  and, after undertaken a process, leaves as a saturated liquid. Calculate

- i) the internal energy of the water as it enters the device (kJ), **(1 mark)**
- ii) the internal energy of the water as it leaves the device (kJ) and **(1 mark)**
- iii) the change in internal energy as a consequence of the process (kJ). **(1 mark)**
- iv) Given the conditions noted in Q3 find the saturation temperature of the water ( $^\circ\text{C}$ ) **(1 mark)**



# Fluid Mechanics and Thermodynamics

## Weekly Assessed Tutorial Sheet 5 (WATS 5)

### TUTOR SHEET – Data used in the Worked Solution

**Q1** The first part of the question is oriented around developing your skills and confidence in interpolation. There will be many instances in both this module and other modules when such a skill is required. Using table 1 sheet 160 asks to find.

- i) What is the density of air at 20.1°C ?
- ii) What is the dynamic viscosity of air at 6.1°C ?
- iii) What is the kinematic viscosity of air at 11.1°C ?
- iv) What is the density of air at 22.8°C ?
- v) What is the dynamic viscosity of air at 10.0°C ?
- vi) What is the kinematic viscosity of air at 7.8°C ?
- vii) At what temperature is the density of air 1.27kg/m<sup>3</sup> ?
- viii) At what temperature is the dynamic viscosity of air 17.7 x 10<sup>-6</sup> N s/m<sup>2</sup> ?

**Table 1.** Properties of air at standard sea level atmospheric conditions.

Temperature (°C)	Density (kg/m <sup>3</sup> )	Dynamic Viscosity (10 <sup>-6</sup> N s/m <sup>2</sup> )
0	1.293	17.1
10	1.248	17.6
20	1.205	18.1
30	1.165	18.6

# Fluid Mechanics and Thermodynamics

## Weekly Assessed Tutorial Sheet 6 (WATS 6)

### TUTOR SHEET – Data used in the Worked Solution

**Q1.** Consider the pipe and tank layout shown in figure 1. Assuming a fluid with a relative density of 1.06 flows through a 68 mm diameter pipe from the large tank to the small tank - calculate -

- i) the velocity of the fluid flowing through the pipe (m/s) **(3 marks)**
- ii) the Reynolds Number of the flow **(1 mark)**
- iii) the likely nature of the flow regime i.e. laminar, transitional or turbulent **(1 mark)**
- iv) the mass flow rate of fluid flowing through the pipe system (kg/s) **(1 mark)**
- v) the volume flow rate of fluid flowing through the pipe system (m<sup>3</sup>/s) **(1 mark)**

Assume now that the velocity for part i) has been calculated to be 2.960 m/s calculate

- vi) the head loss associated with the **pipe** line only (m) **(1 mark)**
- vii) the pressure loss associated with the **pipe** line only (Pa) **(1 mark)**
- viii) the head loss due to all the **minor losses** (m) **(2 mark)**
- ix) the pressure loss due to all the **minor losses** (Pa) **(1 mark)**
- x) the loss coefficient of the **valve** and **(2 mark)**
- xi) the ratio, as a percentage, of the **minor** to the **pipe** losses.(%) **(1 mark)**

You may assume the following :

The friction factor associated with the interaction of the fluid and the pipe surface is 0.00600.

The fluids kinematic viscosity is  $1.13 \times 10^{-6} \text{ m}^2/\text{s}$

The loss coefficients associated with the fluid as it leaves and enters the tanks are 0.78 and 1.02 respectively.

Figure 1. Drawing for Q1.

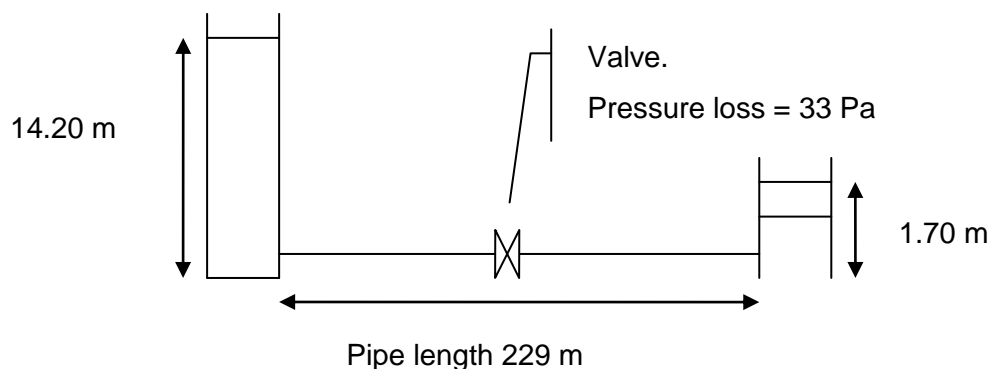

# Fluid Mechanics and Thermodynamics

## Weekly Assessed Tutorial Sheet 7 (WATS 7)

### TUTOR SHEET – Data used in the Worked Solution

**Q1.** A quantity of a fluid, of mass 0.78 kg, is contained in a vertical heat insulated cylinder, sealed at the top by a frictionless piston. The piston has a diameter of 1.38 m and its weight produces a pressure of  $1.25 \text{ MN/m}^2$  in the fluid. The fluid is stirred by a paddle for 53 minutes and during this time the paddle absorbs 0.155 kW of power and the piston rises a distance of 0.40 m. Calculate

- i) The change in internal energy of the fluid during the process (kJ). **(3 mark)**
- ii) The change in the specific internal energy during the process (kJ/kg) **(1 mark)**

**Q2.** A compression ignition engine has as single cylinder with a bore of 17.35cm and a stroke of 24.00cm. The compression ratio is 14 to 1. At the start of the expansion stroke the gases in the clearance volume have a pressure of 9.90 Bars and it is assumed that the expansion is a reversible polytropic process to the law  $PV^{1.29} = C$ . Calculate

- i) The pressure at the end of the stroke (Bar). **(2 mark)**
- ii) The work done (kJ). **(1 mark)**

**Q3.** Provide a multiple-choice type question that could be used to help revision. The question can be from any of the material covered in this subject. Naturally you should present the question and the possible responses together with the correct answer. Whilst there are many possible question types I am only asking for a multiple-choice type question that has **one** correct answer. You should also write the question such that you seek to get the correct answer from **5** possible alternatives. i.e. Yes/No, True/False questions are not allowed. Note it is my intention to use these as part of the revision process. **(3 marks)**

# Fluid Mechanics and Thermodynamics

## Weekly Assessed Tutorial Sheet 8 (WATS 8)

### TUTOR SHEET – Data used in the Worked Solution

**Q1a).** A fluid of relative density 0.98 flows through a pipe of diameter 149 mm at 0.44 m/s. After passing through a gradual reducer the fluid leaves a 72mm diameter pipe and discharges onto a stationary surface. Assuming that the surface slopes at an angle of 'A' degrees from the horizontal plane, as shown below, and that the surface somehow acts as a vane in that the fluid is deflected along its surface - calculate the forces **acting on the surface** for the angles shown in the answer boxes. You may assume that friction effects are negligible.

**Figure Q1a.** Definition of angle 'A' for the inclined surface.

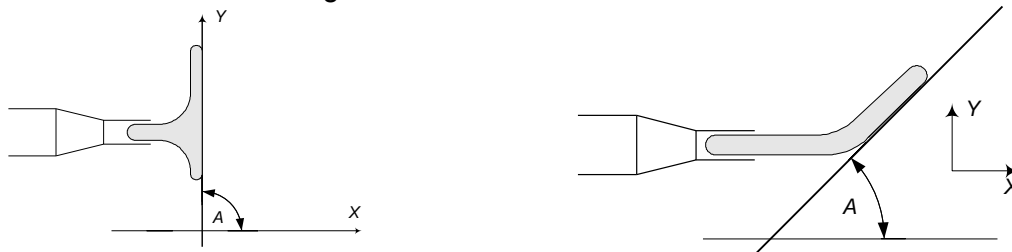

i) $A = 90^\circ$ (X force) (N) <b>(1 Marks)</b>	ii) $A = 10^\circ$ (net force) (N) <b>(2 Marks)</b>	iii) $A = 44^\circ$ (Net force) (N) <b>(2 Marks)</b>	iv) $A = 76^\circ$ (Net force) (N) <b>(2 Marks)</b>

**Q2.** 9 l/s flows through a contracting elbow which has an angle, 'A' of  $29^\circ$  i.e. as shown in figure Q2. Assume the inlet to the bend is 182 mm diameter and the outlet is 59 mm diameter and that the pipe lies in the horizontal plane. The static pressure at the pipe inlet is 4.20 Bar and the fluids specific gravity is 0.97. Calculate the net force and the direction of the force acting on the bend.

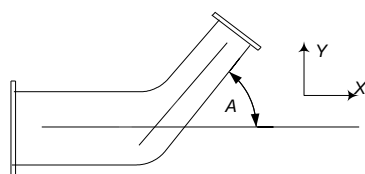

**Figure Q2.** Sketch of bend.

i) Net force (N) <b>(3 Mark)</b>	ii) Direction of force. (As measured anti-clockwise from the top of the horizontal plane. i.e. AS SHOWN in all above examples. <b>(1 Mark)</b>

# Fluid Mechanics and Thermodynamics

## Weekly Assessed Tutorial Sheet 9 (WATS 9)

### TUTOR SHEET – Data used in the Worked Solution

Q1). The torque required to rotate a 5.90 m diameter flat disc in a gas is to be found by measuring the torque required to rotate a geometrically similar disc of 468 mm diameter in a liquid at 567 rad/s.

- i) Calculate the dynamic viscosity ( $\text{N s /m}^2$ ) of a suitable liquid. **(2 marks)**
- ii) If the torque required for the smaller disc is 215 Nm calculate the torque (Nm) required to rotate the full size disc at 5.70 rad/s. **(2 marks)**

For the gas you may assume that the density is  $3.70 \text{ kg/m}^3$  and its dynamic viscosity is  $2.77 \times 10^{-5} \text{ N s/m}^2$ . For the liquid you may assume that the density is  $840.00 \text{ kg/m}^3$ .

Q2) Alternating, oscillating vortices are usually shed from a cylinder when it is exposed to flow conditions having a ratio of inertial forces to viscous forces in the region of 90 – 1000.

Assuming a 9.40 mm diameter cylinder is exposed to a fluid with a dynamic viscosity of  $17.81 \times 10^{-6} \text{ N s/m}^2$  and a density of  $1.29 \text{ kg/m}^3$  calculate -

- i) the lowest speed (m/s) likely to cause vortex shedding to occur **(1 marks)**
- ii) the highest speed likely (m/s) to cause vortex shedding occur. **(1 marks)**

# Fluid Mechanics and Thermodynamics

## Weekly Assessed Tutorial Sheet 10 (WATS 10)

### TUTOR SHEET – Data used in the Worked Solution

Q1). A cylinder of diameter 0.48 m, fitted with a gas tight, frictionless piston contains dry saturated steam at 8 bars. Heat is added until the final temperature is 316 ° C. Determine

- i) the work done (kJ) **(2 marks)**
- ii) the heat supplied (kJ) **(1 mark)**
- iii) the change in internal energy (kJ). **(2 marks)**

You may assume that the piston is free to rise as a consequence of any expansion and at the start of the process the distance between the piston and the bottom of the cylinder is 0.34 m.

Q2) 11.10 kg/s of air enters a turbine at 923 °C with a velocity of 90 m/s. The air expands adiabatically as it passes through the turbine and leaves with a velocity of 114 m/s. It then enters a diffuser where the velocity is reduced to a negligible value. If the turbine produces 2.25 MW calculate

- i) The temperature of the air at exit from the turbine (°C) **(3 marks)**
- ii) The temperature of the air at exit from the diffuser (°C) **(3 marks)**

You may assume that the  $C_p$  for air is constant and has a value of 1.005 kJ/kg K.

# Fluid Mechanics and Thermodynamics

## Weekly Assessed Tutorial Sheet 11 (WATS 11)

### TUTOR SHEET – Data used in the Worked Solution

**Q1)** The performance characteristics of a turbo-compressor are being estimated on a test-rig. The shaft power driving the compressor is 2.00 kW. Air enters the compressor at atmospheric pressure of 1 bar and a temperature of 15°C and is compressed to a pressure of 2.2 bar and temperature of 106°C been estimated. The rate of heat loss from the compressor casing is approximately 200 W and the exit velocity of the compressed air is 120 m/s. Calculate -

- i) the mass flow rate (kg/s) of the air flowing through the compressor. You may assume the inlet velocity to be negligible. **(7 marks)**
- ii) the cross-sectional area (mm<sup>2</sup>) of the exit from the compressor **(5 marks)**

The velocity of the air leaving the compressor has to be reduced to 10 m/s by the use of an adiabatic diffuser. Assuming the pressure at exit is 1 bar determine -

- iii) the temperature (°C) of the air at the diffuser exit **(5 marks)**
- iv) the cross-sectional area (mm<sup>2</sup>) of the diffuser exit **(3 marks)**

It has been decided to cool the air leaving the diffuser back to the initial conditions of 15°C, by means of a water-cooled heat exchanger, determine -

- v) the water mass flow rate(kg/s) required in the heat exchanger if the water inlet temperature is 5°C and the water exit temperature cannot exceed 10°C. **(5 marks)**

You may assume the following:  $C_p$  water = 4.2 kJ/kg K,  $C_p$  air = 1.005 kJ/kg K.

**Q2)** A pipe system carries water from a reservoir and discharges it as a free jet. The entrance to the pipe is via a bell mouth at a depth of X from the reservoir surface. From the entrance the pipe extends 60m, in the horizontal plane before a pipe bend turning the pipe vertically. The pipe then rises for 20m before a second bend turning it back to the horizontal where it extends for another 60m before the exit. For a volume flow rate of 0.10m<sup>3</sup>/s through a 200mm diameter pipe calculate

- i) the velocity of the fluid flowing through the pipeline **(6 marks)**
- ii) the Reynolds Number of the flow **(3 marks)**
- iii) the head loss (m) of the pipe-work (exc. fittings) **(3 marks)**
- iv) the pressure loss (Pa) of the pipe-work (exc. fittings) **(2 marks)**
- v) the head loss (m) of the fittings work (exc. pipe-work) **(3 marks)**
- vi) the pressure loss (Pa) of the fittings (exc. pipe-work) **(2 marks)**
- vii) the required depth X of the bell mouth entrance to the pipe **(6 marks)**

You may take the loss factor of each bend to be 0.40, the bell mouth entrance to be 0.05 and the exit 1.0. The friction factor is to be taken as 0.005. For the purpose of this exercise these values are assumed to be constant and independent of velocity. Further the dynamic viscosity and the fluid density can be assumed to be independent of temperature and have the values of  $1.0300 \times 10^{-3}$  kg m/s and 1000 kg/m<sup>3</sup> respectively.

## Appendix C. Worked Solutions



# WATS 1

## Worked solution

This sheet is solved using the TUTOR data set.

Q1 is essentially oriented around solving the hydrostatic equation. i.e. –

$$\frac{dP}{dZ} = -\rho g$$

Separating the differential terms and getting ready to integrate gives –

$$\int_1^2 dP = \int_1^2 -\rho g dZ$$

Where the pressure and location at position 1 and 2 are shown below.

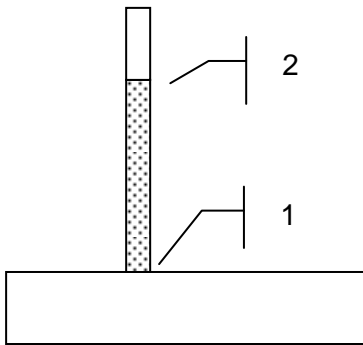

Assuming that density ( $\rho$ ) and gravity ( $g$ ) are constants and do not change with height ( $Z$ ) gives the following –

$$\int_1^2 dP = -\rho g \int_1^2 dZ$$

Hence after integrating this is simply

$$P_2 - P_1 = -\rho g (Z_2 - Z_1)$$

Note that  $(Z_2 - Z_1) = h$  i.e. height of fluid in the piezometric tube and assuming that  $P_2$  is the atmospheric pressure and we are working in gauge pressure gives –

$$-P_1 = -\rho g h \text{ which is the same as } P_1 = \rho g h$$

The rest of the question simply requires us to solve this relationship and using the newly acquired language of the subject and different units applied to the dimensions.

i)  $P_1 = \rho g h$  therefore  $h = \frac{P_1}{\rho g}$  which in this case gives

$$h = 121426 / (1391 * 9.81) = \mathbf{8.90 \text{ m.}}$$

**ii)** relative density = density of fluid / density of water at 4°C

hence  $rd = \frac{\rho}{1000}$  therefore  $\rho = 0.59 * 1000 = 590 \text{ kg/m}^3$ .

$$P_1 = \rho gh = 590 * 9.81 * 0.62 = \mathbf{3588 \text{ Pa.}}$$

**iii)** Don't forget specific gravity = relative density and 1 Bar =  $10^5$  Pa.  
and the height should be in meters!

Don't forget to do the conversions.

$$P_1 = \rho gh \text{ i.e. } \rho = \frac{P_1}{gh} = \frac{1.87 * 10^5}{9.81 * 0.470} \text{ therefore } \rho = 40557 \text{ kg/m}^3.$$

But I have asked for specific gravity. Hence

$$SG = \frac{40557}{1000} = 40.557 \text{ say } \mathbf{40.6}$$

Q2.

Recall the following

Mass = Volume \* density and  
1000 litres =  $1\text{m}^3$ .

**i)** mass of red fluid =  $0.249 * (0.7 * 1000) = \mathbf{174.3 \text{ kg.}}$

**ii)** mass of blue fluid =  $0.133 * 2492 = \mathbf{331.4 \text{ kg.}}$

**iii)**  $\frac{dP}{dZ} = \text{pressure\_gradient} = -\rho g$ . For the red fluid =  $-(0.7 * 1000) * 9.81 = \mathbf{-6867 \text{ Pa/m.}}$

**iv)**  $\frac{dP}{dZ} = \text{pressure\_gradient} = -\rho g$ . For the blue fluid =  $-2492 * 9.81 = \mathbf{-24447 \text{ Pa/m.}}$

**v)** Pressure difference between two points.

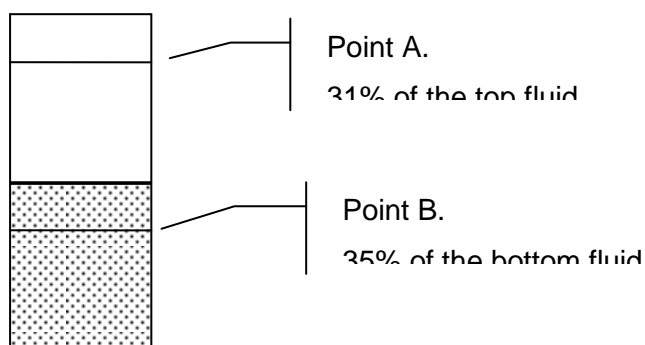

# WATS 2

## Worked solution

This sheet is solved using the TUTOR data set.

**Q1**

$$Force\_On\_Door = \int_{Top\_of\_door}^{Bottom\_of\_door} \rho g w y dy$$

Assuming density ( $\rho$ ), acceleration due to gravity ( $g$ ), and door width ( $w$ ), do not change with respect to fluid depth ( $y$ ) then the above becomes –

$$Force\_On\_Door = \rho g w \int_{Top\_of\_door}^{Bottom\_of\_door} y dy$$

Which after integrating, and inserting our unique values gives

$$Force\_On\_Door = 850 * 9.81 * 0.5 * \left[ \frac{y^2}{2} \right]_{3.1}^{4.8+3.1}$$

$$Force\_On\_Door = 850 * 9.81 * 0.5 * \left[ \frac{7.9^2}{2} - \frac{3.1^2}{2} \right] = 110.1 \text{ kN}$$

**ii)**  $Centre\_of\_P.ressure = \frac{Moments}{Force} = \frac{M}{F}$

$$Moments = \rho g w \int_{Top\_of\_door}^{Bottom\_of\_door} y^2 dy$$

$$Moments = 850 * 9.81 * 0.5 * \left[ \frac{y^3}{3} \right]_{3.1}^{4.8+3.1} = 643.8 \text{ kN m}$$

$Force\_On\_Door = 110.1 \text{ kN}$     Already calculated

$$Centre\_of\_P.ressure = \frac{Moments}{Force} = \frac{643.8}{110.1} = 5.85 \text{ m}$$

**Q2 i)** As before but now with a different fluid and the integration is carried out from the free surface to the bottom of the door. i.e. some of the door is above the fluids free surface.

From the data given the bottom of the door is at a location  $4.8\text{m} - 0.52\text{m} = 4.28\text{m}$  below the free surface.

$$Force\_On\_Door = (0.89 * 1000) * 9.81 * 0.5 * \left[ \frac{4.28^2}{2} - \frac{0^2}{2} \right] = 40.0\text{ kN}$$

See how this force is lower than the force previously calculated (Q1i). This makes sense since a) there is less fluid hence all of the door is not exposed to the fluids force. In this case, this reduction in force, due to the depth reduction, is not offset by the slight increase in density. It is wise to take a few minutes to see if your answers appear to make sense.

**ii)** Following this 'make sense' approach through I would expect the line of action to be less than that calculated in part ii) of Q1. Lets see...

$$Centre\_of\_P.ressure = \frac{Moments}{Force} = \frac{M}{F}$$

$$Moments = 890 * 9.81 * 0.5 * \left[ \frac{y^3}{3} \right]_0^{4.28} = 114.1\text{ kN m}$$

So far so good. i.e. the moments are less.

$$Centre\_of\_P.ressure = \frac{Moments}{Force} = \frac{114.1}{40.0} = 2.85\text{m}$$

Which again is lower so at least it seems to make sense.

**iii)** In this case the force is the same as previously calculated i.e. 39984 N (40.0 kN) but the doors width and height have now been transposed. i.e. –

door height = 0.5m

door width = 4.8m.

$$Force\_On\_Door = \rho g w \int_x^{Door\_height+X} y dy$$

Where x, in the limits of integration, is the depth of fluid from the free surface to the top of the door.

Integrating gives

$$Force\_On\_Door = 890 * 9.81 * 4.8 * \left[ \frac{y^2}{2} \right]_x^{0.5+X}$$

$$Force\_On\_Door = 890 * 9.81 * 4.8 * \left[ \frac{(0.5 + X)^2}{2} - \frac{X^2}{2} \right]$$

Since force on door is already known, i.e. 39984 N we can write

$$39984 = 890 * 9.81 * 4.8 * \left[ \frac{(0.5 + X)^2}{2} - \frac{X^2}{2} \right]$$

Expanding the brackets and tidying gives

$$39984 = 890 * 9.81 * 4.8 * \left[ \frac{0.5^2}{2} + 0.5X \right]$$

From which, X, the additional fluid depth above the door, can be found. In this case it is calculated as **1.658 m**

*iv)* Assuming now that the door lies in the floor of the tank.

$$Force = Pressure * Area$$

$$Area = 0.5 * 4.8 = 2.4m^2$$

Force already calculated as 39984 N hence

$$P.ressure = \frac{Force}{Area} = \frac{39984}{2.4} = 16660 \text{ P A .}$$

Since  $P_{base} = \rho gh$  rearranging for h gives  $h = \frac{P_{base}}{\rho g} = \frac{16660}{(0.89 * 1000) * 9.81}$ .

Therefore depth of tank = **1.91m**.

# WATS 3

## Worked solution

This sheet is solved using the TUTOR data set.

**Q1** This question simply solves Bernoulli's equation and most importantly at the moment assumes no friction losses. i.e. the total energy at 'one point' equals the total energy at 'another point'. i.e. all the energy is converted and none is lost to heat via friction. You will see later in your studies that this is an ideal case.

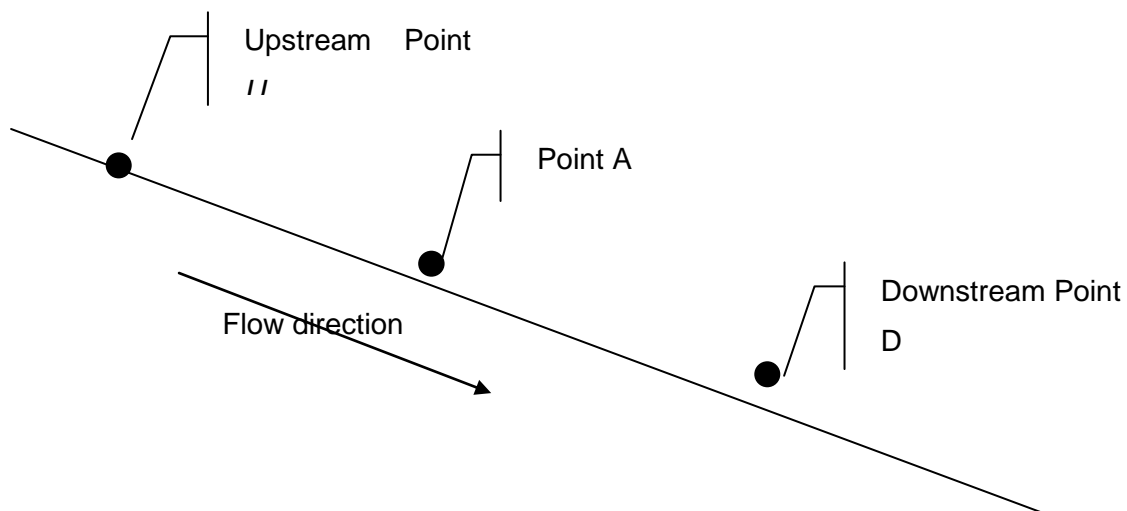

$$P_U + \frac{\rho C_U^2}{2} + \rho g h_U = P_A + \frac{\rho C_A^2}{2} + \rho g h_A$$

Note that as the pipe diameter doesn't change and no fluid is lost or gained the velocity must remain constant at Point  $U$  and  $A$ . Hence, since the kinetic terms are equal on both sides of the equation they can be ignored.

For the potential energy term, set point  $A$  as the datum hence  $h_A = 0$ .

Therefore the modified Bernoulli's equation for this case is

$$P_U + \rho g h_U = P_A \quad \text{writing for } P_U \text{ gives}$$

$$P_U = P_A - \rho g h_U$$

Although the pressure at Point  $A$  ( $P_a$ ) is given the height  $h_U$  is presently unknown, This can, however, be found out from the information given in the sheet.

The slope is 1:27 and the distance to the Upstream Point ( $U$ ) is 77 m.

Hence from Trigonometry

$$\tan\theta = \frac{1}{27} = 0.037037 \text{ Therefore } \theta = 2.12^\circ$$

To find the rise to the upstream point

$$\text{Rise} = \sin\theta * \text{Hypotenuse} = \text{Rise} = \sin(2.12) * 77 = 2.85 \text{ m}$$

Not forgetting to convert the relative density to density gives the pressure at P<sub>U</sub> as

$$P_U = 55 * 1000 - (1000 * 0.61) * 9.81 * 2.85 = 37946 \text{ Pa} = \mathbf{37.9 \text{ kPa.}}$$

Similarly for the pressure at the downstream point (P<sub>D</sub>).

$$P_D + \frac{\rho C_D^2}{2} + \rho g h_D = P_A + \frac{\rho C_A^2}{2} + \rho g h_A$$

Following the same argument as before, the kinetic energy terms can also be ignored here. Again setting the datum for the potential energy term at A gives h<sub>A</sub> = 0.

Therefore the modified Bernoulli's equation for this case is

$$P_D + \rho g h_D = P_A \text{ writing for } P_D \text{ gives}$$

$$P_D = P_A - \rho g h_D$$

Pressure at Point A (P<sub>a</sub>) is known but the height h<sub>D</sub> is not. But the slope is 1:27 and the distance to the downstream Point (U) is 41 m. Hence the **drop** from A to U

Similarly the drop to the downstream point is

$$\text{Drop} = \sin\theta * \text{Hypotenuse} = \text{Drop} = \sin(2.12) * 41 = 1.518 \text{ m}$$

Be careful, Since this is a drop the height h<sub>D</sub> is negative i.e. below the datum therefore

$$h_D = -1.518 \text{ m}$$

Not forgetting to convert the relative density to density gives the pressure at P<sub>D</sub> as

$$P_D = 55 * 1000 - (1000 * 0.61) * 9.81 * (-1.518) = 64081 \text{ Pa} = \mathbf{64.08 \text{ kPa.}}$$

**Q2** similar to Q3 of the tutorials but with a slight twist. The twist tests your understanding!.

Point A is the top of the siphon.

Point B is the discharge of the siphon to atmosphere and lies beneath A.

Point C is the free surface of the tank.

There are no frictional losses in the siphon.

i) Writing Bernoulli's gives

$$P_1 + \frac{\rho C_1^2}{2} + \rho g h_1 = P_2 + \frac{\rho C_2^2}{2} + \rho g h_2$$

Looking at the terms shows that there is only enough information to write this out between the fluids free surface and the discharge. i.e. The pressure at the top of the siphon and the velocity flowing through it is unknown. Hence this location will already provide two unknowns – un-soluble.

Therefore writing this at the free surface and the discharge, location C and B respectively gives -

$$P_C + \frac{\rho C_C^2}{2} + \rho g h_C = P_B + \frac{\rho C_B^2}{2} + \rho g h_B$$

Setting the discharge location, B as the datum gives  $h_B = 0$ .

Also the pressure at the discharge and at the free surface is atmospheric which is the same for both allows this term to be ignored.

Assuming that the tank size is much larger than the pipe diameter, as is often the case in this studies also is to assume that the velocity of fluid in the tank is small i.e.  $\rightarrow 0$  therefore we can write as our modified equation –

$\rho g h_C = \frac{\rho C_B^2}{2}$  Cancelling the density term and writing for  $C_B$ , the velocity at the discharge gives -

$$C_B = \sqrt{2gh_C}$$

The height of the discharge of the discharge above the free surface is obtained from the data given i.e.  $9.2 - 3.3 = 5.9\text{m}$

Therefore  $C_B = \sqrt{2 * 9.81 * 5.9} = \mathbf{10.76 \text{ m/s}}$

ii) The volumetric flow rate is the cross sectional area normal to the flow \* the flowing velocity.

In this case the pipe is circular and the diameter is given as 9.5 cm (95mm) Hence the pipe's CSA is  $0.00709 \text{ m}^2$ .

The volume flow rate is therefore  $0.00709 * 10.76 = \mathbf{0.0763 \text{ m}^3/\text{s}}$ .

iii) The mass flow rate is the volume flow rate \* the fluid density. Again not forgetting to convert the relative density to density gives the mass flow rate as

$0.0763 * (0.61 * 1000) = \mathbf{46.5 \text{ kg/s}}$ .

iv) This is where many of you went wrong. You had to read the question and apply the correct data. It was not identical to question 3 of the tutorial sheet!

In this instance you are trying to find the discharge under the following conditions.

Atmospheric head fixed and head at Point A fixed.



Writing out Bernoulli's in full gives

$$P_1 + \frac{\rho C_1^2}{2} + \rho g h_1 = P_2 + \frac{\rho C_2^2}{2} + \rho g h_2$$

writing around the fluids free surface (C) and the top of the siphon (A) gives –

$$P_C + \frac{\rho C_C^2}{2} + \rho g h_C = P_A + \frac{\rho C_A^2}{2} + \rho g h_A$$

Using the known data, the fact that  $C_C = 0$  and that the datum for the height is fixed at C i.e.  $h_C = 0$  gives –

$$P_C = P_A + \frac{\rho C_A^2}{2} + \rho g h_A \text{ writing for } C_A \text{ the unknown gives –}$$

$$C_A = \sqrt{(2 * (P_C - P_A - \rho g h_A) / \rho)}$$

Therefore the fluid velocity at point A, is

$$C_A = \sqrt{\{(2 * ([10.31 * 1000 * 9.81] - [0.9 * 1000 * 9.81] - [0.61 * 1000 * 9.81 * 3.3]) / [0.61 * 1000]\}}$$

Hence for this new case a new velocity of 15.42 m/s is found. Since this velocity is constant throughout the siphon the new discharge is therefore

$$15.42 * 0.00709 = \mathbf{0.109 \text{ m}^3/\text{s}}$$

Don't get confused here. There are two densities to use. One for the actual density of the fluid i.e.  $0.61 * 1000$  and the other for the values quoted as head of water. The reason for the two is that in the question the head at the top of the siphon and the atmospheric head are quoted as being at a certain head of WATER and the fluid flowing in the tube is not water.

v) The next part of the question asks you to recalculate the length of the discharge below the top of the siphon. Hence again writing Bernoulli's equation in full gives

$$P_A + \frac{\rho C_A^2}{2} + \rho g h_A = P_B + \frac{\rho C_B^2}{2} + \rho g h_B$$

Since  $C_A = C_B$  the kinetic energy terms cancel and taking the datum at point B gives  $h_B = 0$ . Therefore -

$$P_A + \rho g h_A = P_B \text{ writing for } h_A \text{ gives –}$$

$$h_A = \frac{(P_B - P_A)}{\rho g} \text{ hence –}$$

$$h_A = \frac{([10.31 * 9.81 * 1000] - [0.9 * 9.81 * 1000])}{9.81 * (0.61 * 1000)} = 15.43\text{m.}$$

i.e. the discharge is 15.43 m below the top of the siphon.

WATS 4

Worked solution

This sheet is solved using the TUTOR data set.

**Q1** ... calculate the corresponding heat transfer

This question reminds you that for a cyclic system the sum of work = the sum of heat transfer. i.e.

$$\oint W = \oint Q \text{ and taking account of the sign conventions.}$$

In our case we use -

- work done by a system = +ve
- work done on a system = -ve
- heat transferred to a system = +ve
- heat transferred from a system = -ve

Process number	Heat (kJ)	Work (kJ)
1	1.6	-58.6
2	70.6	-11.1
3	-23.9	59.9
4	??	78.2
Sum	48.3	68.4

From which the heat transfer that must be occurring to make the work and heat balance = **20.1 kJ**

**Q2** ... reading data from steam tables

From your 'steam tables'. you will find

- i) Water at 40°C  $h_f = 167.5$  kJ/kg
- ii) Water at 26°C  $h_g = 2548.4$  kJ/kg
- iii) Water at 34°C  $h_g = 2420.4$  kJ/kg

### Q3

i) internal energy as fluid enters device.

From the steam tables the specific internal energy under these conditions (0.2 Bar, saturated vapour) can be read as 2468 kJ/kg.

Since the question asks for internal energy and not specific internal energy this value needs to take account of the mass of fluid flowing into the device. i.e. 0.3 kg/s.

$$\text{Internal energy entering device } (U_g) = u_g * \dot{m} = 2468 * 0.3 = \mathbf{740.4 \text{ kJ/s} = 740.4 \text{ W}}$$

ii) internal energy as fluid leaves device.

Similarly, from the steam tables the specific internal energy under these exit conditions, (0.2 Bar, saturated liquid), can be read as 251 kJ/kg.

Again, the question asks for internal energy and not specific internal energy. Therefore the mass flow rate needs to be considered

$$\text{Internal energy leaving device } (U_f) = u_f * \dot{m} = 251 * 0.3 = \mathbf{75.3 \text{ kJ/s} = 75.3 \text{ W}}$$

iii) change in internal energy as a consequence of this process

$$\Delta U = U_{\text{leaving}} - U_{\text{entering}} = 75.3 - 740.4 = \mathbf{-665.1 \text{ kJ/s} = -665.1 \text{ W}}$$

iv) using the conditions noted, find the saturation temperature

This again comes from looking in the steam tables. In this instance the saturation temperature, which will be constant for this phase change process, is **60.1°C**

# WATS 5

## Worked solution

This sheet is solved using the TUTOR data set.

Q1. Given the table below calculate –

- i) the density ( $\text{kg/m}^3$ ) of air at  $20.10^\circ\text{C}$  **(1 mark)**
- ii) the dynamic viscosity ( $\text{N s /m}^2$ ) of air at  $6.10^\circ\text{C}$  **(1 mark)**
- iii) the kinematic viscosity ( $\text{m}^2/\text{s}$ ) of air at  $11.10^\circ\text{C}$  **(1 mark)**
- iv) the density ( $\text{kg/m}^3$ ) of air at  $22.80^\circ\text{C}$  **(1 mark)**
- v) the dynamic viscosity ( $\text{N s /m}^2$ ) of air at  $10.00^\circ\text{C}$  **(1 mark)**
- vi) the kinematic viscosity ( $\text{m}^2/\text{s}$ ) of air at  $7.80^\circ\text{C}$  **(1 mark)**
- vii) the air temperature ( $^\circ\text{C}$ ) when its density is  $1.270\text{kg/m}^3$  **(1 mark)**
- viii) the air temperature ( $^\circ\text{C}$ ) when its dynamic viscosity is  $17.70 \times 10^{-6} \text{ N s/m}^2$  **(1 mark)**

**Table 1.** Properties of air at standard sea level atmospheric conditions

Temperature ( $^\circ\text{C}$ )	Density ( $\text{kg/m}^3$ )	Dynamic Viscosity ( $10^{-6} \text{ N s/m}^2$ )
0	1.293	17.1
10	1.248	17.6
20	1.205	18.1
30	1.165	18.6

Q2. If  $C = \int_1^2 AdB$  Calculate  $C$  when -

- i)  $AB = \text{constant}$ ,  $A_1 = 208947$ ,  $B_1 = 2.30$  and  $A_2 = 99586$  **(1 mark)**
- ii)  $AB^{1.20} = \text{constant}$ ,  $A_1 = 226573.00$ ,  $B_1 = 3.30$  and  $A_2 = 419610$  **(1 mark)**
- iii)  $A = \text{constant} = 382057.00$ ,  $B_1 = 2.50$  and  $B_2 = 2.70$  **(1 mark)**
- iv)  $B = \text{constant} = 7.30$ ,  $A_1 = 298599$  and  $A_2 = 381272$  **(1 mark)**

i) Table 1 suggests that the constraints for this interpolation are 0°C and 10°C. A chart of the data between these constraints is shown below.

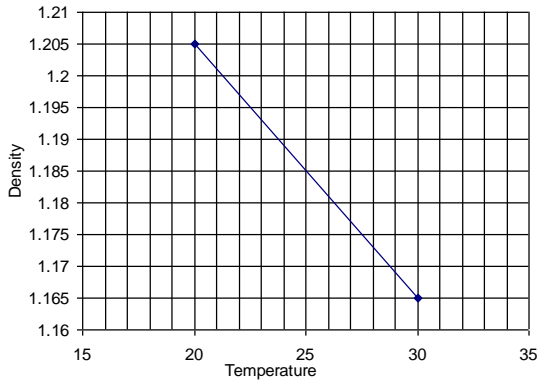

The graph shows -

i) the *lower value* is 20°C and the corresponding density is 1.205 kg/m<sup>3</sup>.

ii) the *higher value* is 30°C and the corresponding density is 1.165 kg/m<sup>3</sup>.

Hence the  $\Delta t = (t_2 - t_1) = 30 - 20 = 10^\circ\text{C}$   
 &  $\Delta \rho = (\rho_2 - \rho_1) = 1.165 - 1.205 = -0.04$  kg/m<sup>3</sup>.

Since the question asks for the density at 20.1°C we have to find how far along the relationship our data point is. i.e. -

$$(\text{temp}' \text{ of req'd density} - \text{temp}' \text{ of lower density}) / (\text{temp}' \text{ of high} - \text{temp}' \text{ of low}).$$

Which in this case is

$$(20.1 - 20) / (30 - 20) = 0.1^\circ\text{C} / 10^\circ\text{C} = 0.01.$$

So the actual density is found via  $0.01 * (-0.04) + 1.205$ . Where the first two parts, (the product), is the proportion of the density difference needed to get to the required value and the final part, the term added, is the value of the lower value.

Hence the density at 20.1 °C is 1.2046 kg/m<sup>3</sup>.

ii) Table 1 suggests that the constraints for this interpolation are 0°C and 10°C. A chart of the data between these constraints is shown below.

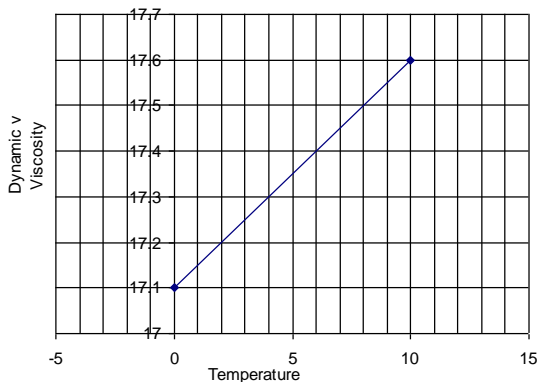

The graph shows -

i) the *lower value* is 0°C and the corresponding dynamic viscosity is  $17.1 \times 10^{-6} \text{ N s / m}^2$

ii) the *higher value* is 10°C and the corresponding dynamic viscosity is  $17.6 \times 10^{-6} \text{ N s / m}^2$

Hence the  $\Delta t = (t_2 - t_1) = 10 - 0 = 10^\circ\text{C}$  &  
 $\Delta\mu = (\mu_2 - \mu_1) = 17.6 - 17.1 = 0.5 \times 10^{-6} \text{ N s / m}^2$

Since the question asks for the dynamic viscosity 6.1°C we have to find how far along the relationship our data point is. i.e. -

$(\text{temp}' \text{ of req'd viscosity} - \text{temp}' \text{ of lower viscosity}) / (\text{temp}' \text{ of high} - \text{temp}' \text{ of low})$ .

Which in this case is

$$(6.1 - 0) / (10 - 0) = 6.1^\circ\text{C} / 10^\circ\text{C} = 0.61$$

So the actual dynamic viscosity is found via  $0.61 \times 0.5 \times 10^{-6} + 1.71 \times 10^{-6}$ . Where the first two parts, (the product), is the proportion of the viscosity difference needed to get to the required value and the final part, the term added, is the value of the lower value.

Hence the dynamic viscosity at 6.1 °C is  $17.4 \times 10^{-6} \text{ N s / m}^2$

The same procedure can be used to find the other data.

A point to note, however, is the fact that  
 kinematic viscosity = dynamic viscosity / density.

As a check the remaining answers are -

- iii)  $1.42 \times 10^{-5} \text{ m}^2/\text{s}$
- iv)  $1.194 \text{ kg/m}^3$
- v)  $17.6 \times 10^{-6} \text{ N s / m}^2$
- vi)  $1.39 \times 10^{-5} \text{ m}^2/\text{s}$
- vii)  $5.11^\circ\text{C}$
- viii)  $12.0^\circ\text{C}$

**Q2.** This question first requires you to undertake the integration and then substitute known or calculated values into the resulting expression.

You are doing this because it will be shown later in your studies that

$$work\_done = \int_1^2 P dv$$

i.e. to calculate work done you will have to undertake some integration hence this work is good practice.

In some instances it may help to draw the relationship. That way you may get a better understanding of what you are doing. It is worth noting also that you are resolving definite integrals. Hence you are undertaking the integration between fixed limits. In these cases whilst you may not have all the *limit data* you do have enough information to allow you to find any unknown limit data. This will be clearer as the worked solution notes proceeds.

Recall for all cases we are resolving  $C = \int_1^2 A db$

i)  $AB = \text{constant}$ ,  $A_1 = 208947$ ,  $B_1 = 2.3$  and  $A_2 = 99586$  ?

Since  $AB = \text{constant}$  and you have data for  $A_1$ ,  $B_1$  and  $A_2$  we should first progress to get the data for  $B_2$ .

$$A_1 = 208947, B_1 = 2.3 \text{ therefore } AB = 480578 \text{ therefore for } B_2 = 480578/A_2 = 4.83$$

This now gives enough data for the upper and lower limits of integration.

To undertake the integration  $C = \int_1^2 A db$ .

$A$  cannot be integrated with respect to  $b$  but the relation  $AB = \text{constant}$  is helpful.

Since we can write  $A = \text{constant}/B$  and substitute this into the integral. i.e.

$$C = \int_1^2 \frac{Const}{B} db \text{ which can be written } C = Const \int_1^2 \frac{1}{B} db . \text{ This can now be integrated to give.}$$

$$C = \ln B \Big|_1^2 \text{ applying the limits to expression gives}$$

$$C = const * \ln B_2 - \ln B_1 \text{ which is the same as}$$

$$C = const * \ln \left( \frac{B_2}{B_1} \right)$$

This expression can now be evaluated to find the value of  $C$ . Remembering also that the

$$'const' \text{ term is } AB \text{ gives } C = AB * \ln \left( \frac{B_2}{B_1} \right) \text{ i.e. } C = 480578 * \ln \left( \frac{4.83}{2.3} \right)$$

In this case  $C = 356137$

ii)  $AB^{1.20} = \text{constant}$ ,  $A_1 = 226573$ ,  $B_1 = 3.3$  and  $A_2 = 419610$  ?

$$B_2 = (\text{constant}/A_2)^{1/1.2} = 1.975$$

The integration is  $C = \int_1^2 A db$  but again  $A$  cannot be integrated wrt  $b$ . In this case

$$AB^{1.2} = \text{Constant} \text{ therefore } A = \frac{\text{Const}}{B^{1.2}} \text{ which is the same as } A = \text{Const} * B^{-1.2}$$

substitute this into the integral. i.e.  $C = \int_1^2 \text{Const} * B^{-1.2} db$  which can be written

$$C = \text{Const} \int_1^2 B^{-1.2} db. \text{ This can now be integrated to give. } C = \text{Const} \left[ \frac{B^{-1.2}}{1-1.2} \right]_1^2 \text{ Application of}$$

the limits gives  $C = \frac{\text{Const}}{(1-1.2)} (B_2^{-1.2} - B_1^{-1.2})$  which is the same as

$$C = \frac{1}{(1-1.2)} (\text{const} * B_2^{-1.2} - \text{const} * B_1^{-1.2})$$

Recall also that  $\text{Const} = AB^{1.2}$  allows us to write

$$C = \frac{1}{(1-1.2)} (A_2 B_2^{1.2} * B_2^{-1.2} - A_1 B_1^{1.2} * B_1^{-1.2}) \text{ Which can be tidied to give}$$

$$C = \frac{1}{(1-1.2)} (A_2 B_2 - A_1 B_1) \quad \text{This can also be written} \quad C = \frac{1}{(1.2-1)} (A_1 B_1 - A_2 B_2)$$

Solving for our values gives

$$C = \frac{1}{(1.2-1)} (266573 * 3.3 - 419610 * 1.97) = -404388$$

iii)  $A = \text{constant} = 382057$ ,  $B_1 = 2.5$  and  $B_2 = 2.7$  ?

In this case  $A = \text{constant}$  therefore, by definition,  $A_1 = A_2 = 325270$ .

$$C = \int_1^2 A db \text{ which for the case of constant } A \text{ can be written as } C = A \int_1^2 db$$

Which when integrated is simply  $C = A B \Big|_1^2$  Using the limits gives  $C = A (B_2 - B_1)$ .

And substituting the values gives

$$C = 382057 * (2.7 - 2.5) \text{ i.e. } C = 764111.$$

iv)  $B = \text{constant} = 7.3$ ,  $A_1 = 298599$  and  $A_2 = 381272$

For the final case  $B = \text{constant}$ . Hence looking at term to be integrated it can be seen that  $db = 0$ , by definition. **Hence here C must also equal 0**



# WATS 6

## Worked solution

This sheet is solved using the TUTOR data set.

Q1 i) the velocity of the fluid flowing through the pipe

The actual total head loss must equal the available head. For this case the available head is  $14.2 - 1.7\text{m} = 12.5\text{m}$ . It is assumed that the flow of water somehow does not drain the large tank nor does it change the height of the fluid of the low tank.

For the system shown the actual total head loss is the sum of the head losses due to –

- a) The exit from the large tank in-to the pipe line.
- b) The pipe itself.
- c) The valve and
- d) The inlet from the pipeline into the small tank.

For fittings, the head loss is usually calculated via

$$\text{Fitting\_head\_loss} = K * \frac{C_m^2}{2g} \text{ (m)}$$

Where-as for straight pipe the head loss is usually calculated via

$$\text{Straight\_pipe\_head\_loss} = \frac{4flC_m^2}{2gd} \text{ (m)}$$

Collecting all the terms together allows us to write

$$\text{Available\_head\_loss} = K_{exit} * \frac{C_m^2}{2g} + \frac{4flC_m^2}{2gd} + \text{Valve\_head\_loss} + K_{entry} * \frac{C_m^2}{2g}$$

Since the pressure loss of the valve is given we need to re-write this as a head loss. i.e.

$\text{head\_loss} = \frac{\text{pressure\_loss}}{\rho g}$  Writing this for the valve and collecting the student specific data gives.

$$12.5 = 0.78 * \frac{C_m^2}{2 * 9.81} + \frac{4 * 0.006 * 229 * C_m^2}{2 * 9.81 * 0.068} + \frac{33}{9.81 * 1.059 * 1000} + 1.02 * \frac{C_m^2}{2 * 9.81} \text{ which is}$$

$$12.5 = 0.03976C_m^2 + 4.1195C_m^2 + 0.003177 + 0.05199C_m^2 \text{ Hence}$$

$$(12.5 - 0.003177) = 4.21C_m^2$$

$$\sqrt{\frac{(12.5 - 0.003177)}{4.21}} = C_m = 1.72 \text{ m/s}$$

ii) the Reynolds Number of the flow.

$Re = \frac{\rho C_m d}{\mu}$  In this case you are given kinematic viscosity ( $\nu$ ) and not dynamic viscosity ( $\mu$ ) hence

$$Re = \frac{C_m d}{\nu} \quad \text{because } \nu = \frac{\mu}{\rho}$$

Application of student specific data gives.

$$Re = \frac{1.72 * 0.068}{1.13 * 10^{-6}} = \mathbf{103504}$$

iii) the likely nature of the flow regime i.e. laminar, transitional or turbulent.

For flow in pipes turbulence is likely when  $Re > 4000$ . In this case, therefore, the flow is likely to be turbulent. Note we do not say the **fluid** is turbulent but the **flow** is turbulent.

iv) the mass flow rate of fluid flowing through the pipe system

$$\dot{m} = \rho \dot{V} \quad \text{and } \dot{V} = AC_m \quad \text{therefore } \dot{m} = \rho AC \quad \text{i.e. for this case}$$

$$\dot{m} = (1.059 * 1000) * \frac{\pi * 0.068^2}{4} * 1.72 = \mathbf{6.62 \text{ kg/s}}$$

v) the volume flow rate of fluid flowing through the pipe system

Volume flow rate  $\dot{V} = AC_m$  therefore for this case

$$\dot{V} = \frac{\pi * 0.068^2}{4} * 1.72 = \mathbf{0.00625 \text{ m}^3/\text{s}}$$

vi) the head loss associated with the **pipe** line only

$$\text{Straight\_pipe\_head\_loss} = \frac{4fC_m^2}{2gd}$$

$$\text{Straight\_pipe\_loss} = \frac{4 * 0.006 * 229 * 2.96^2}{2 * 9.81 * 0.068} = \mathbf{36.09 \text{ m}}$$

vii) Pressure loss associated with the pipe only

$$\text{Pressure\_loss\_straight\_pipe} = \text{head\_loss} * \rho g$$

$$\text{Pressure\_loss\_straight\_pipe} = 36.09 * (1.059 * 1000) * 9.81 = \mathbf{374931 \text{ Pa}}$$

viii) Head losses due to all the minor losses.

In this case the minor losses are derived from the exit from the tank into the pipe, the valve and the exit from the pipe into the small tank. Remembering

$$\text{Minor\_head\_loss} = \frac{K_{\text{fitting}} * C_m^2}{2g}$$

For tank to pipe and pipe to tank losses.

$$\text{Minor\_head\_loss} = \frac{K_{\text{leaves\_tank}} * C_m^2}{2g} + \frac{K_{\text{enters\_tank}} * C_m^2}{2g}$$

$$\text{Minor\_head\_loss} = (0.78 + 1.02) \frac{2.96^2}{2 * 9.81} = 0.804\text{m}$$

For the valve

$$\text{Valve\_head\_loss} = \frac{\text{Valve\_pressure\_loss}}{\rho g}$$

$$= \frac{33}{(1.059 * 1000) * 9.81} = 0.0032\text{m}$$

Therefore total minor losses = 0.804 + 0.003 = **0.807 m**

ix) Pressure losses due to all the minor losses.

$\text{Minor\_pressure\_loss} = \text{Minor\_head\_loss} * \rho g$  therefore

$$\text{Minor\_pressure\_loss} = 0.807 * (1.059 * 1000) * 9.81 = \mathbf{8344 \text{ Pa}}$$

x) the loss coefficient of the **valve**.

Recall the minor head losses, (i.e. fittings etc), are found via -

$$\text{Minor\_head\_loss} = K_{\text{Fitting}} * \frac{C_m^2}{2g} \text{ or in terms of pressure loss is}$$

$$\text{Minor\_pressure\_loss} = K_{\text{Fitting}} * \frac{\rho C_m^2}{2} \text{ writing for the loss coefficient } (K_{\text{valve}}) \text{ gives}$$

$$K_{\text{valve}} = \text{Valve\_pressure\_loss} * \frac{2}{\rho C_m^2} \text{ Which, using the data, gives,}$$

$$K_{\text{valve}} = 33 * \frac{2}{(1.059 * 1000) * 2.96^2} = 0.0071$$

xi) The ratio, as a percentage, of the **minor** to the **pipe** losses.

The minor losses = 8344 Pa

The pipe losses = 374931 Pa

$$\text{Hence the minor losses to the pipe losses} = \frac{8344}{374931} = 0.0225 \text{ which is } \mathbf{2.25 \%}$$

# WATS 7

## Worked solution

**This sheet is solved using the TUTOR data set.**

**Q1 i)** The change in internal energy of the fluid during the process.

The first thing to note is that this problem is a non-flow problem hence the first law for a closed system is relevant. i.e.

$${}_1Q_2 - {}_1W_2 = \Delta U$$

Since the question asks you to calculate the change in internal energy, ( $\Delta U$ ), you simply have to focus on finding the magnitudes and directions of any work and heat transfers.

Note that the question states the cylinder is '*heat insulated*'. Hence for this problem it should be apparent that the heat transfer, ( ${}_1Q_2$ ), to or from the cylinder is zero. Of course you are assuming that it is perfectly insulated and in the absence of any other data, i.e. properties and thicknesses' of the insulating material, for now, that is a fair assumption. So for this case you are only solving

$$-{}_1W_2 = \Delta U$$

Again, a read of the question will highlight the fact that there are TWO work transfers. One of which comes from the paddle stirring the fluid whereas the other comes from the fact that the piston is moving – read below.

The question states the cylinder is sealed at the top by a frictionless piston. This means that the volume of the cylinder may change as the piston slides up and down but the contents of the cylinder will be held at a constant pressure. Think this through - assume the pressure inside the cylinder is somehow increased, this pressure increase would simply move the piston to ensure that its 'self weight' balances that force which is inside the cylinder. Since the piston has a fixed size, fixed mass and gravity doesn't change the force imposed by the piston on the fluid won't change. Hence when it settles it will always be in equilibrium with the pressure below it which must, by definition, match that arising from the piston itself.

This information, fixed pressure and changing volume, is needed for you to calculate the work done due to the moving piston.

Taking the two '*work done*' terms individually

a) Work done due to moving piston

Since  $Work\_done = \int_1^2 P dv$  you now need to find the relationship between pressure and volume. In this case, however, there is no relationship because pressure, ( $P$ ), is constant, so the integral becomes

$$Work\_done = P \int_1^2 dv \quad \text{After integration this becomes } Work\_done = P V_2 - P V_1$$

On application of the 'limits of integration' the result is simply

$$Work\_done = P V_2 - V_1$$

Unfortunately the initial volume, ( $V_1$ ), is not known. Nor is there enough data to be able to calculate it. The final volume, ( $V_2$ ), however, is clearly the initial volume plus the increase in volume due to the moving piston. i.e.  $V_2 = V_1 + additional\_volume$

Using this relationship we can write

$$Work\_done = P V_1 + additional\_volume - V_1 \quad \text{which is the same as}$$

$$Work\_done = P additional\_volume \quad \text{i.e. the } V_1 \text{ terms cancel}$$

The pressure, ( $P$ ), is given and all that remains is to find the *additional\_volume*.

Since the piston is cylindrical this is simply

$$additional\_volume = \frac{\pi D^2}{4} * Length\_of\_piston\_movement$$

Using the student specific data gives

$$additional\_volume = \frac{\pi * 1.38^2}{4} * 0.4 = 0.598 \text{m}^3.$$

$$\text{Hence } Work\_done = 1.25 * 10^6 * 0.598 = 747500 \text{ J} = 748 \text{ kJ}.$$

Note: Since the gas is expanding, i.e. the piston is pushed outwards, this is **work done by the system**. Recall also the sign convention. Work done by the system is **positive**.

b) the work associated by the paddle stirring.

The second component of work associated with this system is that due to the fluid being stirred by the paddle.

The question states that the paddle draws 0.155 kW and that it does this for 53 minutes. Recall that a Watt is simply a Joule/second, ( $1W = 1J/s$ ), hence

$$0.155 \text{ kW} = 0.155 \text{ kJ/s}$$

$$\text{Therefore over the 53 minute duration the paddle draws } 0.155 * (53*60) = 493 \text{ kJ}$$

In this instance, the fluid is being stirred by a paddle. i.e. this is **work done on the system** and hence, applying the sign convention, this is **negative**. i.e. -493 kJ.

The total, net work, done by the system is, therefore **748 - 493 = 255 kJ**

Remembering we are trying to find the changing internal energy i.e.  $-_1W_2 = \Delta U$

In this case this is  $-255 = \Delta U$  kJ.

Hoping you didn't forget the minus sign. This means that internal energy in the system is decreasing.

ii) The change in the specific internal energy during the process.

A specific property is the magnitude of the property per unit mass. Therefore the second part of the question is asking for the change in internal energy per unit mass i.e. (kJ/kg). in terms

of the change in internal energy is  $\Delta U = m\Delta u$  so the change in specific energy  $\Delta u = \frac{\Delta U}{m}$

Using the calculated data from i) above and the student specific data gives

$$\Delta u = \frac{-255}{0.78} = -326 \text{ kJ/kg}$$

**Q2.** i) The pressure at the end of the stroke.

From the question, it is known that  $P_1V_1^{1.29} = P_2V_2^{1.29}$  and also that  $P_1 = 9.9 \text{ Bar}$ .

The compression ratio is 14:1 which is  $\frac{V_2}{V_1} = \frac{V_{clearance} + V_{swept}}{V_{clearance}} = 14$

For completeness this can also be written as  $\frac{V_2}{V_1} = 1 + \left(\frac{V_{swept}}{V_{clearance}}\right) = 14$  therefore

$\left(\frac{V_{swept}}{(14-1)}\right) = V_{clearance}$  and also it is obvious that  $V_{swept} = \pi \frac{D^2}{4} * stroke\_length$

Using the data from the question allows  $V_{swept}$  to be calculated. i.e.

$$V_{swept} = \pi \frac{0.1735^2}{4} * 0.24 = 0.005675 \text{ m}^3.$$

Hence  $V_{clearance} = \left(\frac{V_{swept}}{(14-1)}\right) = \left(\frac{0.005675}{(14-1)}\right) = 0.000437 \text{ m}^3$ . Note also that this is  $V_1$ .

Remembering that  $V_2 = V_{clearance} + V_{swept}$  gives  $V_2 = 0.000437 + 0.005675 = 0.006112 \text{ m}^3$

Inserting all this student specific data into the  $P_1V_1^{1.29} = P_2V_2^{1.29}$  relationship gives

$9.9 * 10^5 * 0.000437^{1.29} = P_2 * 0.006112^{1.29}$  from which  $P_2$  can be found i.e.

$$P_2 = \frac{9.9 * 10^5 * 0.000437^{1.29}}{0.006112^{1.29}} = 32936 \text{ Pa} = 0.329 \text{ Bar}$$

ii) The work done.

$$Work\_done = \int_1^2 Pdv$$

Previous sheets have shown the working for this integral when  $PV^n = C$  and when  $n \neq 1$ . As such this working is not repeated here. The resulting expression is however,

$$work\_done = \frac{1}{(n-1)}(P_1V_1 - P_2V_2)$$

Application of the student specific data gives

$$work\_done = \frac{1}{(1.29-1)} * (9.9 * 10^5 * 0.000437 - 32936 * 0.006112) \\ = 797J = 0.797kJ$$

# WATS 8

## Worked solution

This sheet is solved using the TUTOR data set.

Q1 i) X Force only

The starting point for this problem is  $F = ma$ . Hence you need to find the mass ( $m$ ) and the fluids' acceleration ( $a$ ).

The mass flow rate of the fluid can be found via  $m = \rho AC$  where  $A$  is the cross sectional area normal to the flow direction and  $C$  is the mean flow speed.

Using the student unique data the mass flow rate is

$$m = (1000 * 0.98) * \frac{\pi * 0.149^2}{4} * 0.44 = 7.52 \text{ kg/s}$$

The question also states that the fluid passes through a contraction before being discharged. Hence the velocity on discharge will increase. Since the density of the fluid does not change we can use the fact that the volume flow rate through the main pipe and the discharge pipe must be equal. i.e.  $A_{\text{main\_pipe}} * C_{\text{main\_pipe}} = A_{\text{Discharge}} * C_{\text{Discharge}}$

Applying this to the student unique data gives

$$\frac{\pi * 0.149^2}{4} * 0.44 = \frac{\pi * 0.072^2}{4} * C_2 \text{ from which } C_{\text{Discharge}} \text{ can be found i.e.}$$

$$C_{\text{Discharge}} = 1.88 \text{ m/s}$$

The acceleration is the change in velocity i.e.  $a = C_2 - C_1$ . Noting that the X wise velocity component at the wall must be zero, i.e. it is stationary due to the fact that the wall does not move, gives

$$a = 0 - 1.88$$

Bringing these together gives the force acting on the **FLUID**. i.e. for the first case

$$F = 7.52 * (-1.88) = -14.14 \text{ N.}$$

But since the question asks for the force acting on the surface you must recall that this reaction force is the equal and opposite of the force on the fluid i.e.

$$R = -F = +14.14 \text{ N}$$

The remaining parts of the Q1 are similar except for the fact that they have both X and Y velocity components. These have to be calculated individually and then the net force can be found.



The following answers part ii) of Q1  
 In this student unique case the angle of the incline, 'A' is 10°

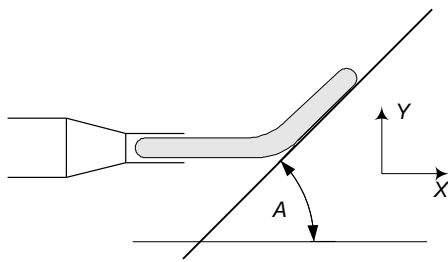

**Figure 1.** Sketch showing angle of incline for WATS 11.

Again note that as the fluid follows the surface it has both an X and Y velocity component.

The force on the fluid in the X direction is still  $F_x = ma_x$  and the acceleration (a) is again found from  $a = C_2 - C_1$  but in the sloped wall case the  $C_2$  term needs to be corrected for the slope. i.e.  $C_{2x} = C_2 \cos A$  hence this gives

$$F_x = 7.52 * (\cos 10^\circ * 1.88 - 1.88) = -0.22 \text{ N}$$

Similarly for the force in the Y direction we can write  $F_y = ma_y$  and  $a = C_2 - C_1$  but note now that at the discharge there is no Y velocity component, i.e. it is all in the X direction therefore  $C_1 = 0$  and the  $C_2$  term needs also to be corrected for the slope i.e.

$$C_{2y} = C_2 \sin A \text{ hence}$$

$$F_y = 7.52 * (\sin 10^\circ * 1.88 - 0) = 2.46 \text{ N}$$

The net force,  $F_N$  is therefore  $F_N = \sqrt{F_x^2 + F_y^2}$  which, on application of these numbers, gives a net force of  $F_N = \sqrt{-0.22^2 + 2.46^2} = \mathbf{2.47 \text{ N}}$ .

Although not asked for the direction of this force on the fluid is  $\text{Direction} = \text{ATAN}\left(\frac{F_y}{F_x}\right)$

which is  $\text{ATAN}\left(\frac{2.46}{-0.22}\right) = 79.5^\circ$  therefore the angle from the horizontal surface is  $180 - 79.5 = 100.5^\circ$

Note again that this is the direction of the force on the fluid the force acting on the surface is equal in magnitude and opposite in direction to that calculated above. i.e.

The force on the surface is 2.47 N and the direction is  $-79.5^\circ$

This is shown graphically below.

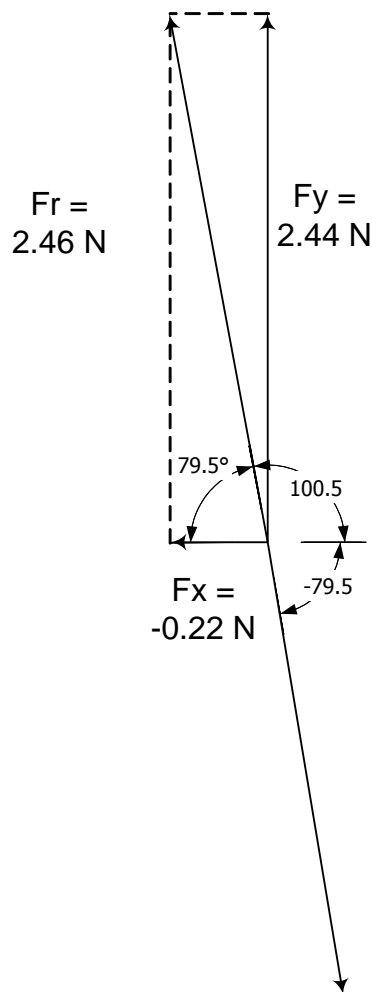

**Figure 2.** Schematic showing the force distribution for student data 160.

Since the other parts of Q1 are carried out using a similar procedure they are not repeated here.

**Q2.** This is similar to the above except for the fact that it is a closed pipe and hence the pressure at one point in the pipe may be different from that at another location. In the previous case the pressure at the discharge was equal to that at the wall hence it was not considered. In this example, however, it needs to be considered.

Note: We need to establish the pressure because the force on the bend will be due to both the pressure and the momentum terms. First recall Bernoulli's equation

$$P_1 + \frac{\rho C_1^2}{2} + \rho g h_1 = P_2 + \frac{\rho C_2^2}{2} + \rho g h_2$$

For this case, the bend is in the horizontal plane and hence the potential energy at the inlet of the bend is equal to the potential energy at the outlet of the bend. In such instances Bernoulli's equation reduces to

$$P_1 + \frac{\rho C_1^2}{2} = P_2 + \frac{\rho C_2^2}{2}$$

Unknowns in the above include the pressure at the outlet and the velocity at both the inlet and the outlet. Fortunately application of the continuity equation allows the velocities to be found.

As before, because the density doesn't change we can state that the volumetric flow rate entering the elbow must equal the volumetric flow rate leaving the elbow.

For the student unique data of 160 this volumetric flow rate is stated as 9 l/s i.e. 0.009 m<sup>3</sup>/s. The inlet to the bend is 182 mm diameter i.e. 0.182m. Hence the velocity at the inlet  $C_{inlet}$  can now be found

$$\dot{V} = A_{inlet} * C_{inlet} \quad \text{for our data this gives } 0.009 = \frac{\pi * 0.182^2}{4} * C_{inlet} \quad \text{hence}$$

$$C_{inlet} = 0.346 \text{ m/s}$$

Similar for the outlet, outlet diameter 59mm we can find the outlet velocity  $\dot{V} = A_{outlet} * C_{outlet}$

$$\text{for our data this gives } 0.009 = \frac{\pi * 0.059^2}{4} * C_{outlet} \quad \text{hence}$$

$$C_{outlet} = 3.29 \text{ m/s}$$

Inserting this and the fact that the static pressure, for this student data at the inlet is 4.2 Bar into the modified Bernoulli's equation gives

$$4.2 * 10^5 + \frac{(0.97 * 1000) * 0.346^2}{2} = P_2 + \frac{(0.97 * 1000) * 3.29^2}{2} \quad \text{i.e.}$$

$$420058.1 = P_2 + 5249.7 \quad \text{hence}$$

$$P_2 = 414808 \text{ N/m}^2 = (4.148 \text{ Bar})$$

The X component of this pressure is  $P_{outlet\_x} = P_{outlet} \cos A = 362795 \text{ N/m}^2$ .

Since  $P = \frac{F}{A}$  it is also true that  $F = P * A$  hence the force due to this pressure at the outlet is

$$F_{x\_pressure\_out} = 362795 * \frac{\pi * D^2}{4} \quad \text{which, for this case, is}$$

$$F_{x\_pressure\_out} = 362795 * \frac{\pi * 0.059^2}{4}$$

$$F_{x\_pressure\_out} = 992 \text{ N}$$

The Force, due to the pressure at the inlet can also be found i.e.

$$F_{x\_pressure\_in} = 4.2 * 10^5 * \frac{\pi * 0.182^2}{4} = 10928 \text{ N}$$

The NET FORCE in the X direction, due to pressure, is  $F_{x\_pressure\_out} - F_{x\_pressure\_in}$  which is  $F_{x\_pressure\_NET} = 992 - 10928 = -9936 \text{ N}$

Similarly for the Y component of pressure at the outlet this is

$$P_{outlet\_y} = P_{outlet} \sin A = 201101 \text{ N/m}^2.$$

The force in the Y direction due to the outlet pressure is therefore,

$$F_{y\_pressure} = 201101 * \frac{\pi * 0.059^2}{4} = 550 \text{ N.}$$

Due to the bends' geometry it can be seen that there is no force in the Y direction, due to pressure, at the inlet.

The NET FORCE in the Y direction, due to pressure, is  $F_{y\_pressure\_out} - F_{y\_pressure\_in}$  which is  $F_{y\_pressure\_NET} = 550 - 0 = 550 \text{ N}$

The force also needs to be found due to the acceleration. i.e. the  $F = ma$  terms still have to be included. Again, since the procedure was outlined step by step for Q1 that detail will not be covered again. The following does however list important check points for your use.

X component of exit velocity = 2.879 m/s  
 Y component of exit velocity = 1.596 m/s  
 X component of inlet velocity = 0.346 m/s  
 Y component of inlet velocity = 0.0 m/s

The mass flow rate is  $\dot{m} = \rho AC$  which, for this data set, is 8.73 kg/s.

The Force in the X direction due to acceleration is  $F_{x\_acceleration} = m * (C_{outlet\_x} - C_{inlet\_x})$  i.e.  
 $F_{x\_acceleration} = 8.73 * (2.879 - 0.346) = 22 \text{ N}$

The TOTAL X wise Force is therefore the  $F_{x\_acceleration} + F_{x\_pressure}$

$$F_{x\_Total} = F_{x\_acceleration} + F_{x\_pressure} = 22 + (-9936) = -9914 \text{ N.}$$

The Force in the Y direction due to acceleration is  $F_{y\_acceleration} = m * (C_{outlet\_y} - C_{inlet\_y})$  i.e.  
 $F_{y\_acceleration} = 8.73 * (1.596 - 0.0) = 14 \text{ N}$

The TOTAL Y wise Force is therefore the  $F_{y\_acceleration} + F_{y\_pressure}$

$$F_{y\_Total} = F_{y\_acceleration} + F_{y\_pressure} = 14 + 550 = 564 \text{ N.}$$

The NET FORCE is  $F_N = \sqrt{F_x^2 + F_y^2}$  which, using the above calculated data is

$$F_N = \sqrt{-9914^2 + 564^2} = 9951 \text{ N}$$

The direction of this **force on the fluid** is  $Direction = ATAN(\frac{F_y}{F_x})$  which is  $ATAN(\frac{550}{-9914}) =$

$3.3^\circ$  therefore the angle from the horizontal surface is

$180 - 3.3 = 176.7^\circ$  But the question asks for the force on the SURFACE i.e. in this case this is  $-3.3^\circ$  but since the question specifically asks for this measurement to be presented anti-clockwise the answer that should be given is  $360 - 3.3 = 356.7^\circ$

Hence the FORCE ON THE SURFACE is 9951 N and the direction is  $360^\circ - 3.3^\circ = 356.7^\circ$  (measured anti clockwise).

This is shown graphically below.

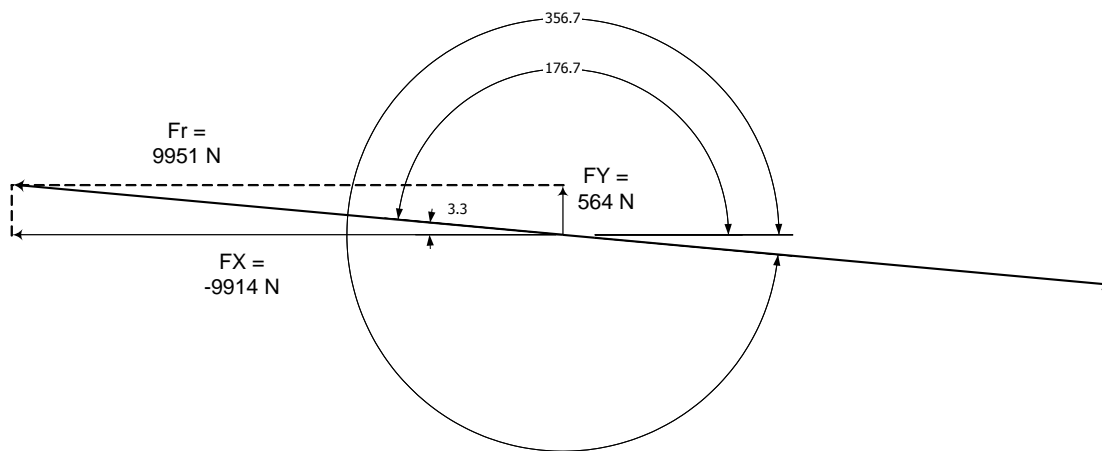

# WATS 9

## Worked solution

This sheet is solved using the TUTOR data set.

It is assumed for this that you already have the correct dimensionless groups. In some instances, however, these groups may be given, whereas in others you may have to construct them yourself. This exercise tries to get you recall and use them.

**Q1** i) This part of the question is aimed at getting you to use the dimensionless groups and use this information to relate each case to each other. Using your notes the dimensionless group for this case is  $\frac{\rho D^2 N}{\mu}$

Therefore  $\frac{\rho_g D_r^2 N_g}{\mu_g} = \frac{\rho_l D_l^2 N_l}{\mu_l}$  where the subscripts *g* and *l* relate to the *gas* and *liquid* configurations respectively.

Since all the data is know for the gas case

$$\frac{\rho_g D_r^2 N_g}{\mu_g} = \frac{3.7 * 5.9^2 * 5.7}{2.77 * 10^{-5}} = 26503354$$

Which, by definition, must also be the same value that arises from solving the dimensionless group for the liquid case. i.e.

$$26503354 = \frac{\rho_l D_l^2 N_l}{\mu_l}$$

$$\text{Substituting the known values gives } 26503354 = \frac{840 * 0.468^2 * 567}{\mu_l}$$

$$\text{Therefore, } \mu_l = \frac{840 * 0.468^2 * 567}{26503354} = 0.0039358 \text{ N s/m}^2 = \mathbf{3.936 * 10^{-3} \text{ N s/m}^2}$$

**Q1** ii) The second part of the question uses the following relationship

$$\frac{\tau_g}{\rho_g D_g^5 N_g^2} \text{ and as before } \frac{\tau_g}{\rho_g D_g^5 N_g^2} = \frac{\tau_l}{\rho_l D_l^5 N_l^2}$$

$$\text{For the gas group we can write } \frac{\tau_g}{3.7 * 5.9^5 * 5.7^2}$$

For the liquid group we can write  $\frac{215}{840 * 0.468^5 * 567^2}$

Relating these two groups together gives  $\frac{\tau_g}{3.7 * 5.9^5 * 5.7^2} = \frac{215}{840 * 0.468^5 * 567^2}$

From which we can find the torque required to rotate the big disc in gas i.e. ( $\tau_g$ )

In this case this is  $\tau_g = \frac{215}{840 * 0.468^5 * 567^2} * 3.7 * 5.9^5 * 5.7^2 = \mathbf{30.477 \text{ Nm}}$

**Q2.** This question requires you to recall the fact the **ratio of inertial forces to viscous forces** is the much used 'dimensionless group' known as the **Reynolds Number**.

The question also reinforces the idea of dimensional analysis and shows how dimensionless groups can be used in engineering studies. i.e. in this case it is not the fluid velocity or the fluid's viscosity that are singularly important. For this vortex shedding pattern to occur then it is the combination of these variables, with others, that determine the likelihood of this phenomenon.

For the *lower velocity*  $RE = 90$ . Recalling the definition of the Reynolds Number i.e.

$RE = \frac{\rho CL}{\mu}$  and for this flow configuration the characteristic length, L, is the cylinder diameter. Applying the student unique data into the above gives

$$90 = \frac{1.29 * C * 9.4 * 10^{-3}}{17.81 * 10^{-6}} \quad \text{Hence the lower velocity, } C_{min}, \text{ is } 0.132 \text{ m/s}$$

For the *higher velocity*, i.e.  $RE = 1000$  and application of the student unique data gives –

$$1000 = \frac{1.29 * C * 9.4 * 10^{-3}}{17.81 * 10^{-6}} \quad \text{Hence the higher velocity, } C_{max}, \text{ is } 0.1469 \text{ m/s}$$



# WATS 10

## Worked solution

**This sheet is solved using the TUTOR data set.**

**Q1** The first thing to note about this question is that it is a closed system. The cylinder within the piston will move and no frictional forces are included. Since heat is added to the cylinder the gases will expand forcing the piston to rise.

The starting point for a closed, (non-flowing), first law problem is  $Q_{1-2} - W_{1-2} = \Delta U$

i) The work done

$$Work \_ done = \int_1^2 P dv$$

i.e. you now need to find the relationship between pressure and volume. In this case, however, there is no relationship because pressure, ( $P$ ), is constant, so the integral becomes

$$Work \_ done = P \int_1^2 dv \quad \text{After integration this becomes}$$

$$Work \_ done = P V_2 - V_1$$

On application of the '*limits of integration*' the result is simply

$$Work \_ done = P (V_2 - V_1)$$

Hence we now need to find  $V_1$  and  $V_2$

Using the fact that at the start of the process the fluid is saturated steam will allow the initial specific volume to be found.

For this data this is

$$v_1 = 0.2403 \text{ m}^3/\text{kg}$$

And using the fact that the final temperature and pressure are known, i.e. 316°C at 8 bars - Don't forget for this problem the pressure remains constant allows the final specific volume to be found. –

For this data this is

$$v_2 = 0.334 \text{ m}^3/\text{kg}$$

Note you may have to interpolate from the tables.

To calculate the actual work done and not the work pr unit mass you now have to calculate the mass of the fluid in the cylinder.

This can be found via

$$mass = \frac{A * L}{v_1} \quad \text{which is } mass = \frac{\pi * 0.48^2 * 0.34}{4 * 0.2403} = 0.256 \text{ kg}$$

Hint: Don't forget  $\frac{1}{v} = \rho$

This now allows the work done to be calculated.

$$Work\_done = (8 * 10^5) * 0.256 * (0.334 - 0.2403) = 19190 \text{ J} = 19.2 \text{ kJ}$$

ii) The heat supplied.

The heat supplied can be found via

$$Q_{1-2} = \Delta U + W_{1-2}$$

The above has just found the work done, ( $W_{1-2}$ ), but since there isn't data on the change in internal energy the above cannot yet be solved. Hence the following will answer part iii) first and then come back with the remaining data.

iii) The change in internal energy.

Using the steam tables at the conditions noted for part i) above gives

$$u_1 = 2577 \text{ kJ/kg and}$$

$$u_2 = 2824 \text{ kJ/kg. Again there may have been a need to interpolate from the tables.}$$

The change in specific internal energy,  $\Delta u$ , is therefore

$\Delta u = u_2 - u_1 = 2824 - 2577 = 247 \text{ kJ/kg}$ . But since the question asks for 'change in internal energy' and not 'change in specific internal energy' this value needs to be multiplied by the mass.

$$\text{i.e. by definition } \Delta U = m * \Delta u = 0.256 * 247 = 63.2 \text{ kJ}$$

This information can now be fed back to help answer part ii) i.e

$$Q_{1-2} = \Delta U + W_{1-2} = 63.2 + 19.2 = \mathbf{82.4 \text{ kJ}}$$

Q2.

This question is different from that above due to the fact that the fluid is flowing through a series of 'components' thus making it an open system. Since no mass is stored it is reasonable to assume that the system is in steady-state: in this instance the Steady Flow Energy Equation (SFEE) applies. i.e.

$$Q_{1-2} + m(h_1 + \frac{C_1^2}{2} + gZ_1) = W_{1-2} + m(h_2 + \frac{C_2^2}{2} + gZ_2)$$

**Figure 1.** Sketch to support Q2.

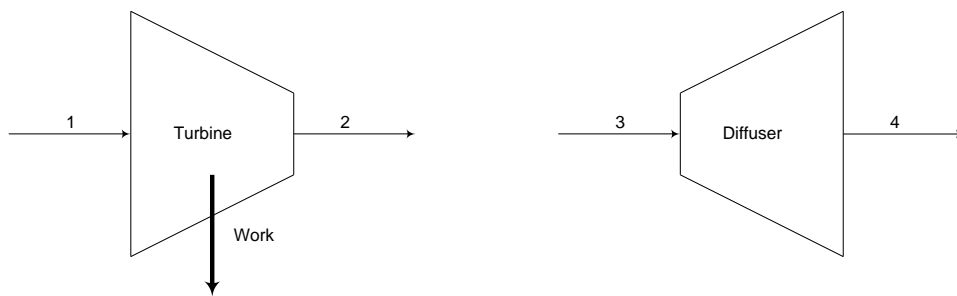

Although the question states that the fluid flows through the two components you need to tackle them as individual entities. i.e. solve for the turbine first and then solve for the diffuser.

For the turbine

A read of the question will show that the potential energy at the inlet is the same as the potential energy at the outlet. By definition, since it is a turbine we are dealing with, there will be some work-done. That is the job of a turbine !; and for this student 'data set' the work-done is given as 2.25 MW. Further, since no data is given regarding heat transfer we will assume that it is adiabatic. Adding this data to a sketch of the problem gives

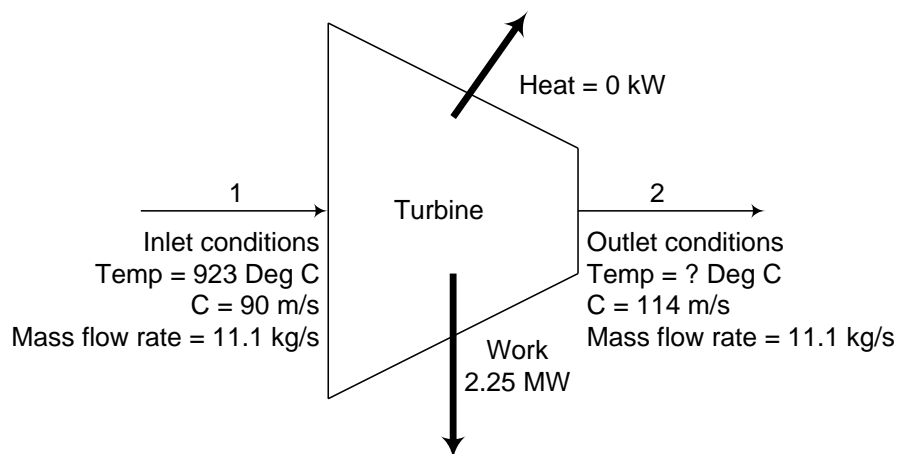

In this case, therefore, the SFEE reduces to

$$m\left(h_1 + \frac{C_1^2}{2}\right) = W_{1-2} + m\left(h_2 + \frac{C_2^2}{2}\right) \text{ This can be re-arranged to give}$$

$$-W_{1-2} = m\left(h_2 - h_1 + \frac{C_2^2 - C_1^2}{2}\right)$$

And since the question asks for the temperature at the outlet of the turbine it is worth remembering the relationship  $(h_2 - h_1) = Cp(T_2 - T_1)$ . Substituting this into the above gives

$$-W_{1-2} = m \left[ Cp(T_2 - T_1) + \frac{(C_2^2 - C_1^2)}{2} \right]$$

Inserting the student unique data into the above gives

$$-2.25 * 10^6 = 11.1 * \left[ (1.005 * 1000) * (T_2 - [923 + 273]) + \frac{(114^2 - 90^2)}{2} \right]$$

From which  $T_2 = 992$  K Which is  $992 - 273 = 719^\circ\text{C}$ .

For the diffuser

Noting that the steam flows from the turbine to the diffuser allows us to obtain more data. i.e. the inlet velocity and the inlet temperature to the diffuser is clearly the exit velocity and exit temperature from the turbine. In a diffuser no work is done and also assuming that the diffuser behaves adiabatically allows a sketch of this to be shown.

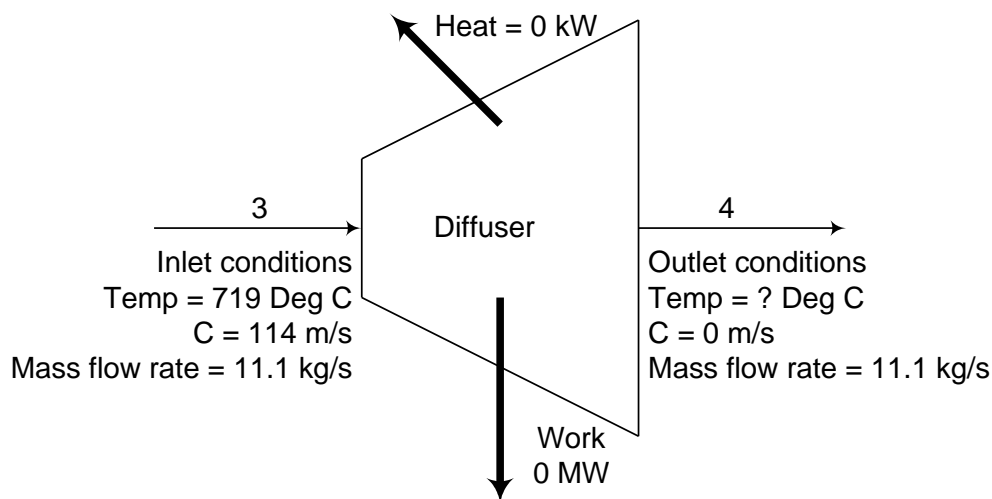

The SFEE for the diffuser can now be stated as

$$0 = m \left[ Cp(T_4 - T_3) + \frac{(C_4^2 - C_3^2)}{2} \right]$$

Which upon substitution of the student unique vales gives

$$0 = 11.1 * \left[ (1.005 * 1000) * (T_4 - [719 + 273]) + \frac{(0^2 - 114^2)}{2} \right]$$

From which  $T_4$  can be found.

$T_4 = 998$  K Which is  $998 - 273 = 725^\circ\text{C}$ .

# WATS 11

## Worked solution

This sheet is solved using the TUTOR data set.

**Q1.** This is an open system combining two components / devices (compressor and diffuser). Since the two devices are installed in series we will tackle them individually.

For reference we will assume the following

Point 1 entry to compressor  
Point 2 exit from compressor

Point 3 entry to diffuser  
Point 4 exit from diffuser

For the compressor

i) Mass flow rate

Assuming the compressor is horizontal removes any changes in potential energy for the systems hence the following applies

$$\dot{Q} - \dot{W} = \dot{m} \left[ (h_2 - h_1) + \left( \frac{C_2^2 - C_1^2}{2} \right) \right] \text{ remembering also that}$$

$$\dot{Q} \dot{m} C_p (T_2 - T_1) = \dot{m} (h_2 - h_1) \quad \text{gives}$$

$$\dot{Q} - \dot{W} = \dot{m} \left[ C_p (T_2 - T_1) + \left( \frac{C_2^2 - C_1^2}{2} \right) \right]$$

Substituting known values, and remembering the sign convention for work and heat gives,

$$-200 - (-2000) = \dot{m} \left[ 1005(379 - 288) + \left( \frac{120^2 - 0^2}{2} \right) \right]$$

$$\text{Written for mass flow rate gives } \dot{m} = \frac{1800}{98655} = \mathbf{0.018 \text{ kg/s}}$$

ii) Cross sectional area of compressor exit.

By continuity

$$\dot{m} = \rho_2 A_2 C_2 \quad \text{Or } \dot{m} = \frac{A_2 C_2}{v_2} \text{ i.e. using specific volume in lieu of density.}$$

We now have two unknowns with one equation - insoluble. Recourse to the ideal gas laws will yield information on the specific volume i.e.

$$P_2 v_2 = RT_2 \text{ rearranged for specific volume gives } v_2 = \frac{RT_2}{P_2}$$

$$\text{Substituting known values gives } v_2 = \frac{287 * 379}{2.2 * 10^5} = 0.494 \text{ m}^3/\text{kg}$$

Using this data allows the continuity equation to be solved and hence calculate the exit cross sectional area

$$A_2 = \frac{\dot{m} v_2}{C_2} = A_2 = \frac{0.18 * 0.494}{120} = 0.0000741 \text{ m}^2 = \mathbf{74.1 \text{ mm}^2}$$

For the diffuser

iii) Temperature of the air at the exit of the diffuser

Re-writing the SFEE for the diffuser gives.

$$\dot{Q} - \dot{W} = \dot{m} \left[ C_p (T_4 - T_3) + \left( \frac{C_4^2 - C_3^2}{2} \right) \right]$$

Note the rate of heat transfer = 0W, (adiabatic) and the rate of doing work = 0W.

Therefore

$$C_p (T_4 - T_3) = \left( \frac{C_3^2 - C_4^2}{2} \right) = 1005(T_4 - 379) = \left( \frac{120^2 - 10^2}{2} \right)$$

From which  $T_4 = 386.1\text{K} = 113.1^\circ\text{C}$

iv) Cross sectional area of diffuser exit.

This follows the same ideas as given in the answer to part ii). In this case the specific volume at the outlet of the diffuser = 1.108 m<sup>3</sup>/kg.

hence

$$A_4 = \frac{\dot{m} v_4}{C_4} = A_4 = \frac{0.18 * 1.108}{10} = 0.00019944 \text{ m}^2 = \mathbf{199.44 \text{ mm}^2}$$

v) mass flow rate of water

This simple requires you to construct an energy balance for the air and the water i.e.

$$\dot{Q}_{\text{water}} = \dot{Q}_{\text{air}}$$

$$\dot{m}_{\text{air}} C_{p\text{air}} (T_4 - T_1) = \dot{m}_{\text{water}} C_{p\text{water}} (15 - 10)$$

rearranged for mass flow rate of water gives

$$\dot{m}_{water} = \dot{m}_{air} \frac{C_{pair}}{C_{pwater}} \left( \frac{113.1 - 15}{15 - 10} \right) = \mathbf{0.085 \text{ kg/s}}$$

Q2.

i) velocity of flow through pipe-line, By continuity

$$\dot{V} = A_{pipe} C_{pipe}$$

$$A_{pipe} = \frac{\Pi D^2}{4} = 0.03142 \text{ m}^2$$

$$C_{pipe} = \frac{\dot{V}}{A_{pipe}} = \frac{0.1}{0.03142} = \mathbf{3.183 \text{ m/s}}$$

ii) Reynolds number of flow

$$RE = \frac{\rho C_{pipe} D_{pipe}}{\mu} = \frac{1000 * 3.183 * 0.2}{1.03 * 10^{-3}} = \mathbf{618058}$$

iii) head loss of pipe excluding fittings

$$h_f = \frac{4fLC_m^2}{2gD} = \frac{4 * 0.0047 * (60 + 20 + 60) * 3.183^2}{2 * 9.81 * 0.2} = \mathbf{6.796 \text{ m}}$$

iv) Pressure loss of pipe excluding fittings

$$Pipe\_Pressure\_Loss = \rho g h_f = 1000 * 9.81 * 6.796 = \mathbf{66669 \text{ Pa}}$$

v) head loss of pipe fittings excluding pipe-work

$$Fittings\_Head\_Loss = \sum k \frac{C^2}{2g} = (1.0 + 0.4 + 0.4 + 0.05) * \frac{3.183^2}{2 * 9.81} = \mathbf{0.955 \text{ m}}$$

vi) Fittings pressure loss excluding pipe-work

$$Fittings\_Pressure\_Loss = \rho g h_{fittings} = 1000 * 9.81 * 0.955 = \mathbf{9368 \text{ Pa}}$$

vii) Required depth

Constructing an energy balance using Bernoulli's equation gives

$$P_1 + \frac{\rho C_1^2}{2} + \rho g Z_1 = P_2 + \frac{\rho C_2^2}{2} + \rho q Z_2 + \rho g h_{\text{fittings\_ \& \_ pipe}}$$

Making some assumptions and stating what we know i.e.

$$P_1 = P_2 = P_{\text{atmos}} \text{ therefore cancels}$$

Tank is large compared to pipe therefore  $C_1 = 0$

$$h_1 = x - 20$$

$$h_2 = 0$$

This gives

$$\rho g (x - 20) = + \frac{\rho C_2^2}{2} + \rho q Z_2 + \rho g h_{\text{fittings\_ \& \_ pipe}}$$

i.e.  $x$  is the distance to the bell mouth and in this case '20' is the rise of the pipe from the bell mouthed entry. Substituting known values, and cancelling common density gives

$$9.81(x - 20) = \frac{3.183^2}{2} + 9.81 * 7.736$$

Dividing through by gravity and making  $x$  the subject gives

$$x = 20 + \frac{3.183^2}{2 * 9.81} + 7.736 \text{ from which } x = 20 + 0.5164 + 7.736 = \mathbf{28.25m}$$



## Appendix D. The pilot WATS Questionnaire (2002/03)

#	Question	SA	A	Slightly Agree	Slightly Disagree	D	SD
1	I really hope the WATS approach is followed through into other second and final year modules						
2	I think other subjects could benefit from this teaching, learning and assessment approach.						
3	I believe the WATS will help me in the examination						
4	I would still do the WATS even if they did not count towards the final grade						
5	I would regard myself as someone that doesn't need deadlines to make me work						
6	I really like doing the WATS and getting a mark each week						
7	The feedback I get from the WATS is really useful						
8	The WATS do not hinder my studies on other modules						
9	Not allowing any lateness for the WATS is an excellent idea						
10	Like the new electronic WATS submission facility						
11	Overall, I would rate the WATS as excellent						

## Appendix E. The revised WATS Questionnaire

#	Question	SA	A	NAND	D	SD
1	You only do well in the WATS if you understand the subject					
2	I completely trust these automated data collection and marking facilities					
3	Having student unique data is an excellent idea					
4	The fact that the WATS are weekly is an excellent idea					
5	I think other subjects could benefit from this WATS approach					
6	I believe the WATS will help me in the examination					
7	I would still do the WATS even if they did not count towards the final grade					
8	Having a weekly league table of student performance is an excellent idea					
9	I really like doing the WATS each week					
10	I really like getting a mark each week for my efforts					
11	The WATS do not hinder my studies on other modules					
12	Not allowing any lateness for the WATS is an excellent idea					
13	Overall, I would rate the WATS as excellent					

