

OPTIMIZING THE HYDROCYCLONE FOR BALLAST WATER TREATMENT USING COMPUTATIONAL FLUID DYNAMICS

Daniel K M^cCluskey¹ & Prof. Arne E Holdø²

Energy & Environmental Applied Research Group

Engineering & Computing, Coventry University, United Kingdom

1. d.mccluskey@coventry.ac.uk 2. arnhol@hin.no

Abstract

Environmental concern related to the transfer of Invasive Aquatic Species by ships ballast water has given rise to the development of a vast array of ballast water treatment systems. The complex environmental challenges and tight operational characteristics of marine vessels limits the scope of technologies used for Ballast Water Treatment. As a result few technologies have progressed beyond the Research and Development stage; however one of the most promising technologies for ship board use is the Cyclonic Separator, or Hydrocyclone. Despite the use of hydrocyclones in a wide variety of engineering applications they have yet to be successfully adapted towards the removal of suspended sediment and marine organisms from large volumes of ballast water. This paper details the operational characteristics of Ballast Water Hydrocyclones, employing empirical and experimental data to validate the use of a Detached Eddy Simulation (DES) turbulence model with Computational Fluid Dynamics simulations (CFD).

1. Introduction

Approximately 80% of world trade is transported by shipping with a world shipping fleet of approximately 85,000 vessels with many of these ships using sea water as ballast. The current practice of using water as ballast is essential to ensure the safe operation of vessels, and equates to approximately 3 to 5 billion tonnes of water transported by marine vessels annually [1]. This transfer of water around the world has an enormous biological effect on coastal and freshwater ecosystems, due in part, to the significant quantity of organisms and organic matter suspended in ballast water. The ready transport of debris and micro-organisms, coupled with the complex design of ballast tanks can also result in large quantities of sediment being deposited within ballast tanks. This can create a breeding ground in which certain organisms may flourish. Upon deballasting these organisms are deposited freely in coastal waters and at ports around the world and, providing the environment is suitable, they can establish themselves.

While there has been significant legislation to encourage the use of ballast water treatment (BWT) mechanisms on board ships there has, as yet, been little uptake by ship owners and operators. One of the primary factors preventing the widespread use of BWT is the significant costs associated with installations. One possible solution is to adopt a two-fold approach to the ballast water issue providing the ship owners with additional benefits.

In this respect the inclusion of a filtration or separation device which minimises the uptake of sediment forming debris could be key. By reducing

sediment within ballast tanks there are a number of additional benefits aside from the reduction in invasive species. The key benefits include an increase in the deadweight allowance for cargo; this also manifests itself as a reduction in the overall unladen mass of the vessel which can result in increased fuel efficiency. Finally the corrosive effects of the sediment are minimised which increases the timeframe between applications of protective coatings and enables a more thorough structural inspection process to be conducted within ballast tanks.

Environmental concern related to the transfer of Invasive Aquatic Species by ships ballast water has given rise to the development of a vast array of ballast water treatment systems however few systems physically removal particles. In this respect the following work introduces the hydrocyclone as an optimised component for BWT. However the vast majority of existing ships in operation have significantly different structural layouts and operating condition as illustrated in Table 1. The work presented here aims to address the current difficulties associated with system design. Computational Fluid Dynamics (CFD) will be presented as a viable tool for hydrocyclone design.

Type of Vessel	DWT	Under Ballast Conditions			
		Normal (tonnes)	% of DWT	Heavy (tonnes)	% of DWT
Bulk Carrier	250,000	75,000	30	113,000	45
	150,000	45,000	30	67,000	45
	70,000	25,000	36	40,000	57
	35,000	10,000	30	17,000	49
Tanker	100,000	40,000	40	45,000	45
	40,000	12,000	30	15,000	38
Container	40,000	12,000	30	15,000	38
	15,000	5,000	30	n/a	
General Cargo	17,000	6,000	35	n/a	
	8,000	3,000	38	n/a	
Passenger	3,000	1,000	33	n/a	

Table 1. Representative Ballast Capacities of various vessel types. Source: [2]

2. Hydrocyclones

At present many treatment mechanisms are currently under development for onboard ship use in an attempt to prevent the transfer of unwanted organisms around the world. There are only two commercially available BWT systems at present, one of which utilises a hydrocyclone in conjunction with UV radiation while the other uses cavitation effects to induce Gas Bubble Trauma in the suspended particles. In this instance the hydrocyclone system is the only system which aims to remove particles at point of ballasting.

By design Hydrocyclones have no moving parts and do not require back flushing. The fluid enters tangentially and a conical section induces spiral flow. This rotational flow causes dense solid particles to be forced towards the walls of the separator where they are discharged (see Figure 1), this discharge makes up for less than 5% of the total ballast water intake [3]. However some organisms have a similar density to water and as such are not affected by the centripetal force acting within the cyclone, as a result they are always discharged.

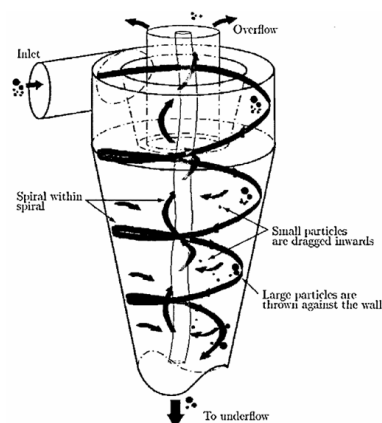

Figure 1. Schematic showing hydrocyclone flow and operation.

3. Turbulence modelling

One of the key issues surrounding the accurate modelling of the hydrocyclone within the CFD environment is appropriate selection of turbulence models. The nature of turbulent flow varies significantly from application to application and the fluctuations in the velocity field can have a significant impact on the transport of momentum, energy, and species concentration. The latter of which is key when dealing with hydrocyclones. There are a number of turbulence models, each employed to model different turbulence characteristics within the domain. The need for turbulence models arises due to the necessity to simplify the governing equations. This is often achieved through either time averaging or equation manipulation in order to remove smaller scales, which would otherwise require a significant amount of computing time to solve. However these modified equations contain a number of additional unknown variables, hence turbulence models are used to determine these unknowns. It is worth noting that there is no single universal turbulence model, and the selection of an appropriate turbulence model is critical in order to achieve appropriate results. The selection of the most suitable model is determined by analysing the known characteristics of the flow to be simulated, taking into account issues such as the physics of the flow, the level of accuracy required, and the intended purpose of the results. Furthermore in order to utilise turbulence models to predict flow, it is necessary to understand the limitations of each turbulence model.

In this instance the primary focus of the work is to determine whether the Detached Eddy Simulation model can be utilised in place of a Large Eddy

Simulation turbulence model. The DES model is considered to be a viable option in this instance as the near wall regions are modelled with an unsteady Reynolds Averaged Navier Stokes (RANS) model, while filtered versions of the same models are used away from the near-wall.

The central core of the domain is generally treated with LES as this is the region where the large turbulence scales have most significance [4]. With the DES model utilised for the respective subgrid models in this region. Additionally the respective RANS models are used in the near-wall region.

In terms of computational cost it is generally considered that the use of a DES model is a suitable compromise in situations where a full LES model may result in unnecessarily high computational expenditure but where a standard RANS model may not provide suitable accuracy [5].

In FLUENT the built in DES option uses the standard Spalart-Allmaras model. This model uses the distance to the closest wall to determine the length scale, d , significant in determining the level of production and destruction of turbulent viscosity.

4. Modelling the Flow in a Square Profile Duct with 180° bend.

The inlet section of the hydrocyclone is one of the most fundamental regions within the cyclone domain. The presence of the vortex finder directly downstream of the inlet provides a curved physical obstruction which can give

The numerical computation of turbulent flow within a square sectioned pipe with a 180 Degree bend has previously been conducted by Choi et al [6] respectively. In both cases the computational work was compared to experimental data by Choi et al [7] and an algebraic second moment closure model was combined with a mixing length model as an improvement on previous $k-\epsilon$ eddy viscosity models. As part of their study a number of significant assumptions and simplifications were made including modelling the domain about a central plane and employing a symmetry function.

Furthermore the total cells used in the CFD work by Choi et al had a total cell count of approximately 235,000. This was justified at the time as:

“a minimum of about 25 nodes from the wall to the duct centre is sufficient to obtain a grid-independent velocity field at this level of turbulence modelling for bend flows without recirculation.”

In this instance the previous numerical and experimental data is used to compare new CFD work using three different turbulence models, Renormalised $k-\epsilon$, Reynolds stress model (RSM) and Detached Eddy Simulation (DES). The primary focus is to identify whether the Detached Eddy Simulation can be applied to Hydrocyclone modelling in order to increase modelling accuracy. As a result the assumptions of Chang and Choi have been ignored for the comparative study in order to identify secondary, cross centreline flows and to ascertain the significance of the inherent time dependent nature of the separated flow regime. Furthermore rather than

applying an experimentally derived inlet boundary profile to the CFD domain the inlet conditions have been modelled by increasing the inlet length to 30 times the hydraulic diameter. This inlet length increase was first discussed in the latter work by Choi et al. The resultant fully 3D domain has been modelled with approximately 2.8 million cells.

Furthermore Choi et al utilised quadratic upstream differencing for convection in order to improve the impact of numerical errors. However it was deemed by Choi et al that this had no significant impact on the computed flow pattern at the 90 Degree plane. As the 90 degree plane can be considered in isolation to a number of the potential numerical eccentricities of the original CFD, and the fact that this plane exhibits a high degree of flow separation, it forms the basis of the comparison between the various CFD simulation results, including historical work and the experimental results of Chang et al.

The fundamental purpose of numerical simulation in ballast water hydrocyclone design is to accurately model the internal cyclone flow regime in order to determine particle separation without the need for costly experimental prototypes. In this respect the DES turbulence model has been chosen as it applies a RANS model close to the wall to predict the attached boundary layers while adopting a Large Eddy Simulation (LES) model in order to resolve the time-dependent, three dimensional large eddies thus incorporating the benefits of a higher accuracy model while reducing the necessary computational time. The results of the test case simulations will ascertain

whether DES can successfully be used to determine the flow regimes within a hydrocyclonic separator (hydrocyclone).

The data for the DES simulation is presented for five rakes corresponding to the original ERCOFTAC data points as indicated in Figure 3. While there are five specific reference planes, each with five rakes, the primary focus here is on the 90° plane as discussed, the plane of symmetry falls inline with the rake at $2Y/D=0$ and has also been shown.

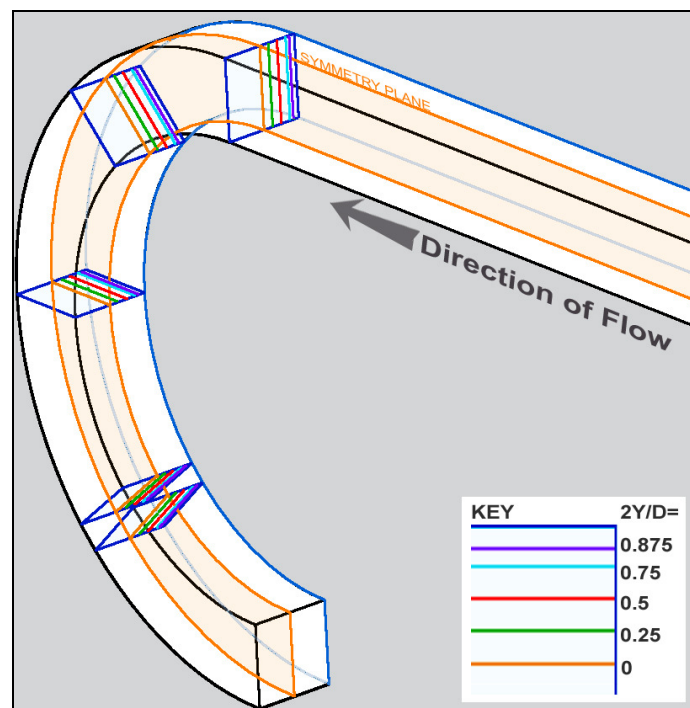

Figure 3. Location of reference rakes ($2Y/D$) on key planes.

The domain fluid is set as Air at standard conditions such that the following parameters apply:

- Kinematic viscosity: $\nu = 1.72 \times 10^{-5} \text{ m}^2/\text{s}$.
- Inlet bulk axial velocity $W_B = 11 \text{ m/s}$.

- Reynolds number based on the bulk axial velocity W_B : $Re = W_B D / \nu = 56,690$.

Note: These parameters have been presented within the ERCOFTAC data [8]. It is assumed that the most likely cause for the numerical disagreement in the reverse calculation of these parameters is rounding within the calculated value for the Inlet bulk axial velocity where a Reynolds number of 56,690 would give rise to an Inlet bulk axial velocity of 10.85m/s. As this number is close to the specified 11 m/s the disagreement has been ignored.

The Primary comparative data source of the velocity profiles at the 90° Plane are given by Choi and are shown in Figure 4.

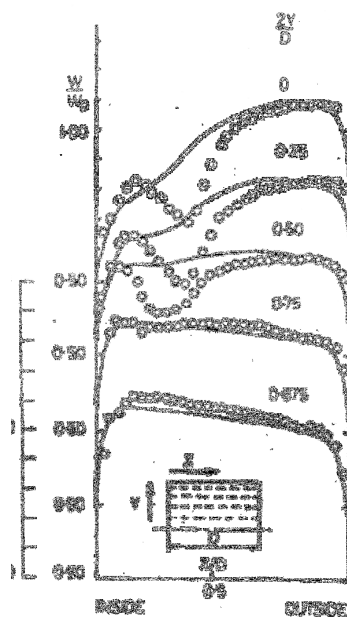

Figure 4 Streamwise mean velocity profiles on the 90° plane. Measurements are shown as point samples while the CFD work of Johnson (1984) is shown by a straight line.

All CFD simulations have been conducted using the commercially available software package FLUENT [Version 6.3.26]. The simulation has been run using default settings where applicable, specifically:

- The solver is pressure based using 2nd order implicit unsteady formulation and the gradient option selected is Green-Gauss Cell based.
- The DES model has been applied with the Spalart-Allmaras selected as the associated RANS model. There are no additional User Defined Functions incorporated. The default model coefficients were used such that:

Model Constants						
Cdes	Cb1	Cb2	Cv1	Cw1	Cw3	Prandtl Number
0.65	0.1355	0.622	7.1	0.3	2	0.667

- Discretization for pressure is standard; momentum is bounded central differencing and modified turbulent viscosity is first order upwind. This also incorporates the SIMPLE pressure-Velocity Coupling.
- Time step size was fixed at 0.005s for time dependent analysis once the simulations were shown to have stabilised.

5. Discussion

One of the most significant findings of the earlier work was the inability of the numerical modelling to accurately model the “velocity hole” that occurs due to the separation of flow round the bend. In this respect a number of additional simulations have been conducted in order to identify whether any improvement in the numerical modelling is the result of turbulence model selection, increased mesh density, or higher performance computing. With regards to the turbulence model selection the data presented here does not

intend to fully justify each model in turn but instead aims to provide an overview of the modelled flow behaviour within the square profile duct.

Furthermore in order to evaluate the mesh density each turbulence model has been conducted on a high density grid with a minimum grid size equal $1/3$ of the inlet turbulent length scale. The inlet turbulent length scale is taken as 7% of the hydraulic diameter of the duct. This dense mesh should ensure that the small flow structures are resolved. In addition to the high density grid an additional set of simulations have been conducted utilising a version of the grid adopted by Choi et al realised in 3D in order to maintain and cross flows.

6. Results

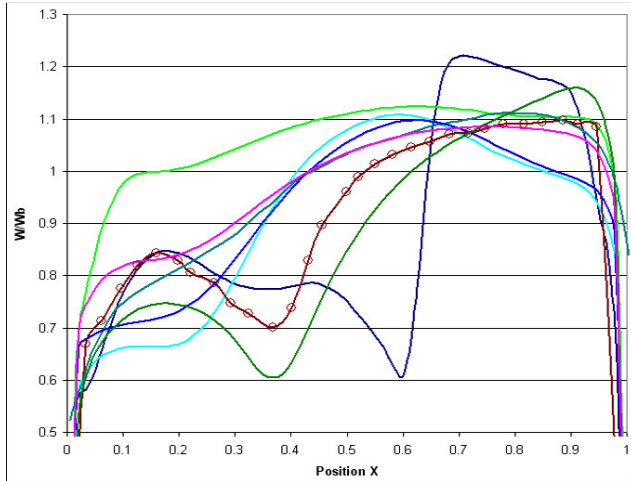

2a). Rake $2Y/D=0$ on 90° Plane

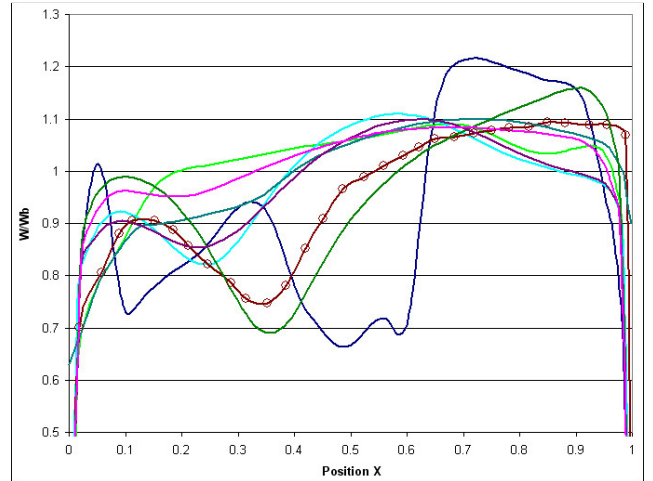

2b). Rake $2Y/D=0.25$ on 90° Plane

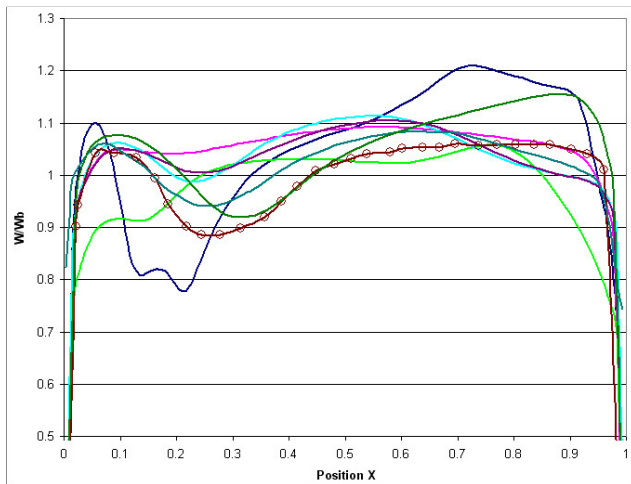

2c). Rake $2Y/D=0.5$ on 90° Plane

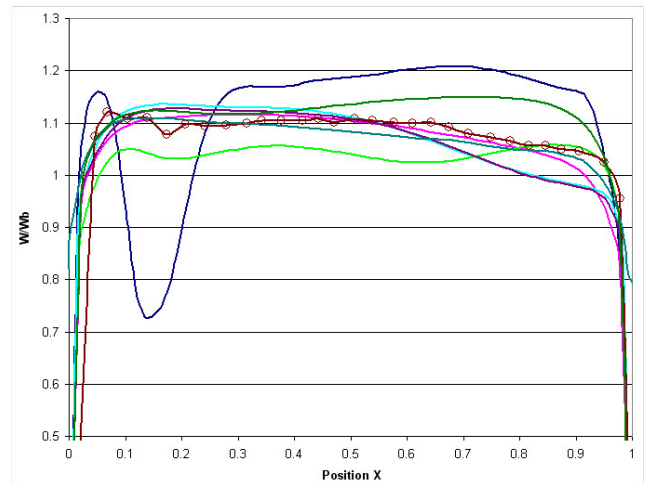

2d). Rake $2Y/D=0.75$ on 90° Plane

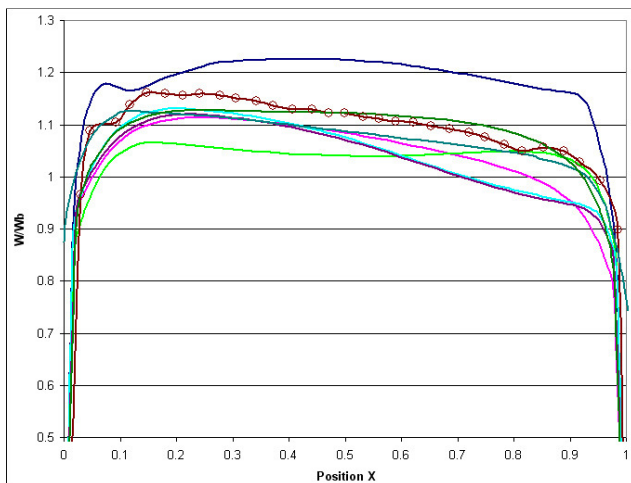

2e). Rake $2Y/D=0.875$ on 90° Plane

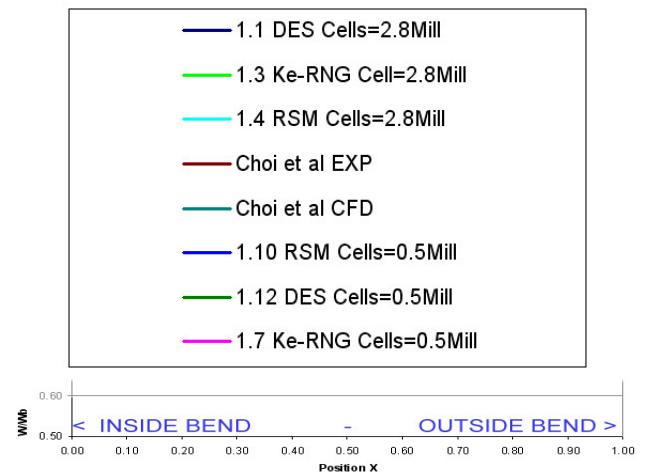

Key to chart data

Chart 2 (a-e) Numerical model comparison data for 90° Plane of the ERCOFTAC 180° Square Profile Duct for six turbulence model variations.

In both simulations using the DES turbulence model the results are presented at a specific time step, in each case at approximately 4.5 seconds. As such the resultant data is an instantaneous moment in time and therefore identifies specific periodic flow phenomenon within the duct. With regards to the analysis conducted using the higher density grids there is a reasonable correlation in most circumstances; however the DES data indicates additional flow phenomenon not presented in the previously published work (See Figure 5a). A possible cause of any discrepancy may lie in the fact that the reference data is presented as a series of mean velocity profiles for both experimental and numerical data. As a result of this averaging process the complex secondary time dependent flows have been omitted from the data sets, however it is known that there are complex secondary flows associated with both square profile ducts and highly separated flows. An examination of a number of closely spaced time steps of the DES model indicate the significance that flow variance may have on the domain (See Chart 2).

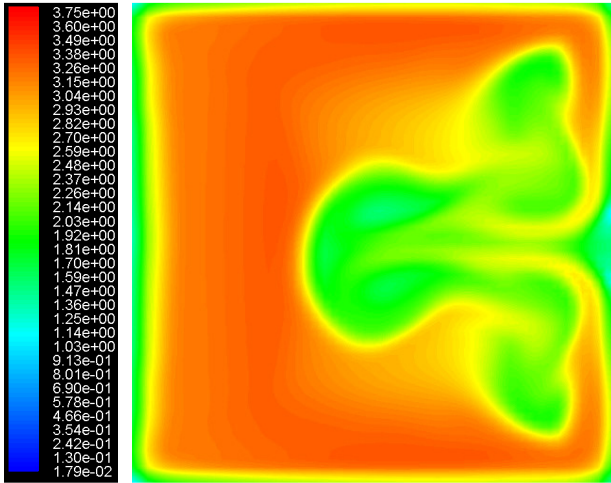

Run No 1.1 5a). DES. Cells: 2.8 Million. t=4.5s

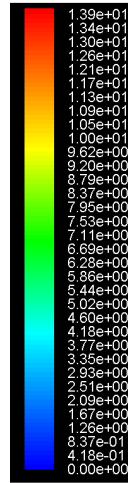

Run No 1.12 5b). DES. Cells: 0.5 Million. t=4.5s

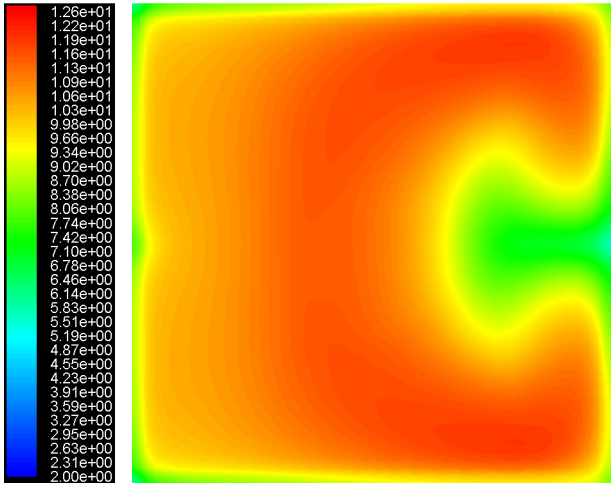

Run 1.4 5c). RSM. Cells: 2.8 Million. t=n/a

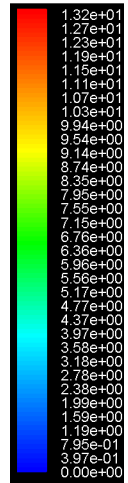

Run No 1.10 5d). RSM. Cells: 0.5 Million. t=n/a

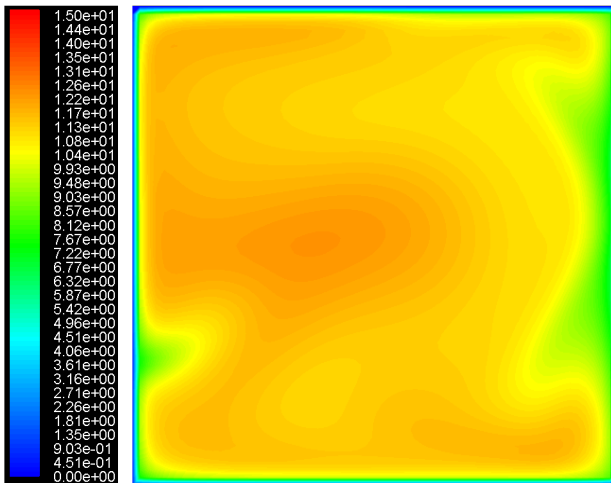

Run No 1.3 5e). $k-\epsilon$ RNG. Cells: 2.8 Million. t=n/a

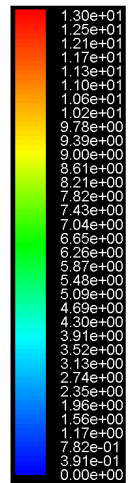

Run No 1.7A 5f). $k-\epsilon$ RNG. Cells: 0.5 Million. t=n/a

Figure 5(a-f). Images show contours of velocity magnitude on the 90° Plane. Note: Image is shown with the inside edge of the bend on the Right.

The fact that the DES approach employs a less rigorous equation to model the near-wall may also result in an incorrectly formed boundary layer at the point of separation. A long flow time in excess of 18 complete flow through has been simulated in an attempt to negate this. In addition it is possible that the time dependent nature of the LES aspect of the DES model may prevent a completely developed flow from arising as flow structures may develop periodically or even intermittently. Furthermore the implicit filtering mechanism of the FLUENT software may result in numerical errors during the resolution of individual time steps which would adversely affect the boundary layer and subsequent flow separation. In these instances the extended inlet domain and the high number of complete flow throughs should mitigate these effects.

A number of these points can be emphasised by referring to the results of the lower density grid simulations (See Figures 5b, 5d & 5f). In this case the coarseness of the grid may prevent the smaller flow structures from being resolved. It is these smaller structures which are considered to be responsible for the development of the intermittent and periodic flow phenomenon. As a result the coarse grid in all likelihood causes the DES simulation to act in a similar manner to a Reynolds Averaged Navier Stokes analysis. The data presented for the coarse mesh DES simulation backs up this argument as the values at the reference points on the target plane appear “smoothed out”, and are more in line with a time averaged data set.

In comparison to the DES data the Renormalized $k-\epsilon$ model show little evidence of picking up the complex secondary flows, however this was an

expected result. Surprisingly the Reynolds Stress Model exhibited a flow which was reasonably indicative of the experimental measurements considering the relatively low computational cost of the model. However in both cases the inability to accurately model specific time dependent aspects of the flow may result in results which are unsatisfactory for ballast water hydrocyclone design. For illustrative purposes the contours of velocity magnitude on the symmetry plane are shown in Figures 6a-f. These images clearly show the complex nature of the separated flow as it flows round the curve. In this instance the 2.8 million DES model shows significantly more detail than its counterpart, where the velocity gradients show evidence of “smoothing”.



6a). DES. Cells: 2.8 Million

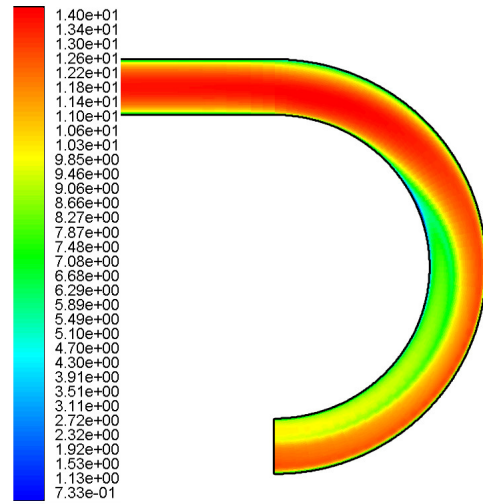

6b). DES. Cells: 0.5 Million

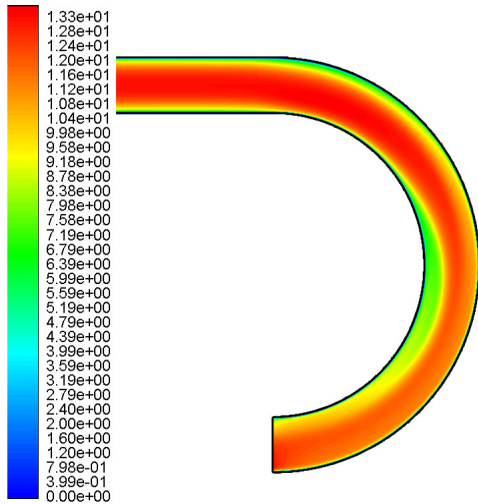

6c). RSM. Cells: 2.8 Million.

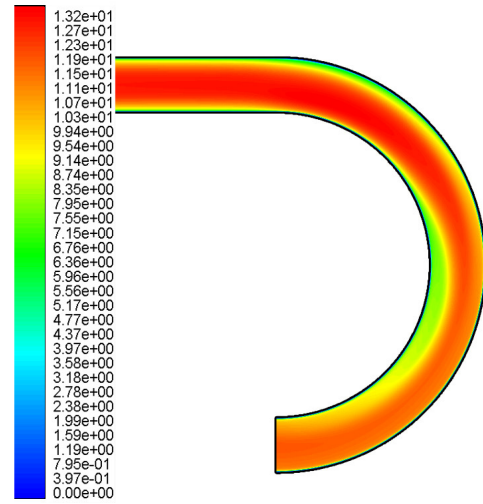

6d). RSM. Cells: 0.5 Million

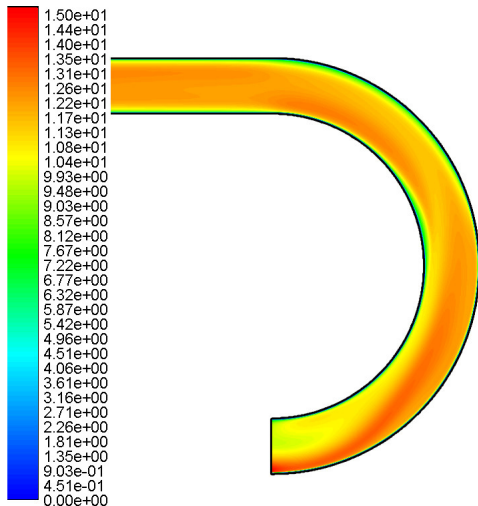

6e). $k-\epsilon$ RNG. Cells: 2.8

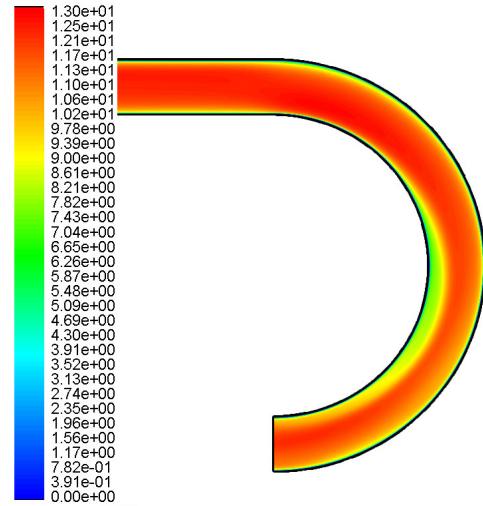

6f). $k-\epsilon$ RNG. Cells: 0.5 Million.

Figure 5(a-f). Images show contours of velocity magnitude on the 90° Plane. Note: Image is shown with the inside edge of the bend on the Right.

7. Future Work: Application of CFD modelling to Cyclone Design

The long term intention of the ERCOFTAC test case assessment is to identify the suitability of the DES turbulence model for ballast water hydrocyclone design. To this end a number of simplified flow simulations have been conducted on a 75mm hydrocyclone conforming to design parameters defined by Rietema [9-12]. Rietema conducted a series of experiments in order to ascertain the optimised geometries for hydrocyclones. As a result of his experiments he determined a set of design ratios for hydrocyclone geometries for the purpose of optimal dimensionless cut size and return to underflow – that is the removal of solid particles from the liquid in which it is suspended. The optimum cyclone geometry ratios ascertained by Rietema are as follows, with the parameters referenced in Figure 7:

Design Ratio	Value
L/D	~ 5
b/D	= 0.28
e/D	= 0.34
l/D ~	0.4

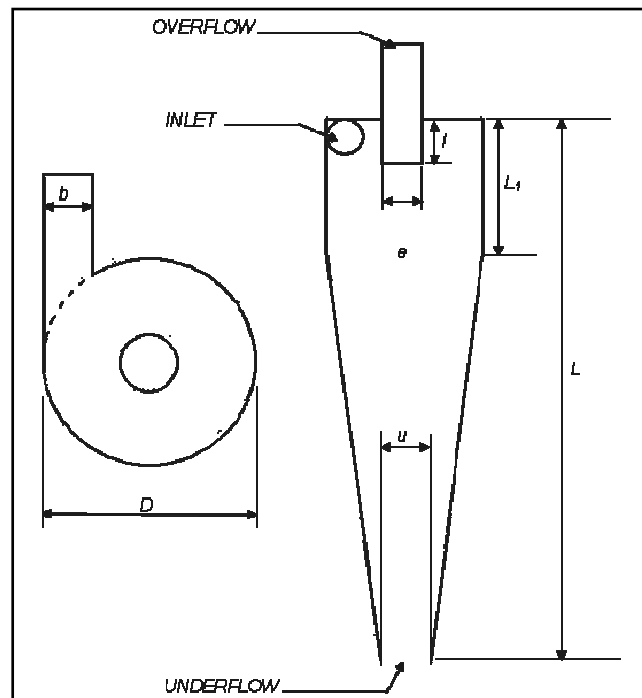

Figure 7. Rietema Optimum Cyclone – Design Parameters

The numerical analysis of this work has yet to be ascertained with respect to the experimental separation efficiencies; however the velocity contour plots of the three turbulence models, Detached Eddy Simulation, Reynolds Stress and Renormalised $k-\epsilon$ models, used in the ERCOFTAC test case analysis are shown in Figure 8. In this application it is evident that the DES model resolves more complex flow phenomenon than the other two when the same boundary conditions are applied. Interestingly the RSM model does not show the same potential when applied to swirling flows as it did to highly separated flows.

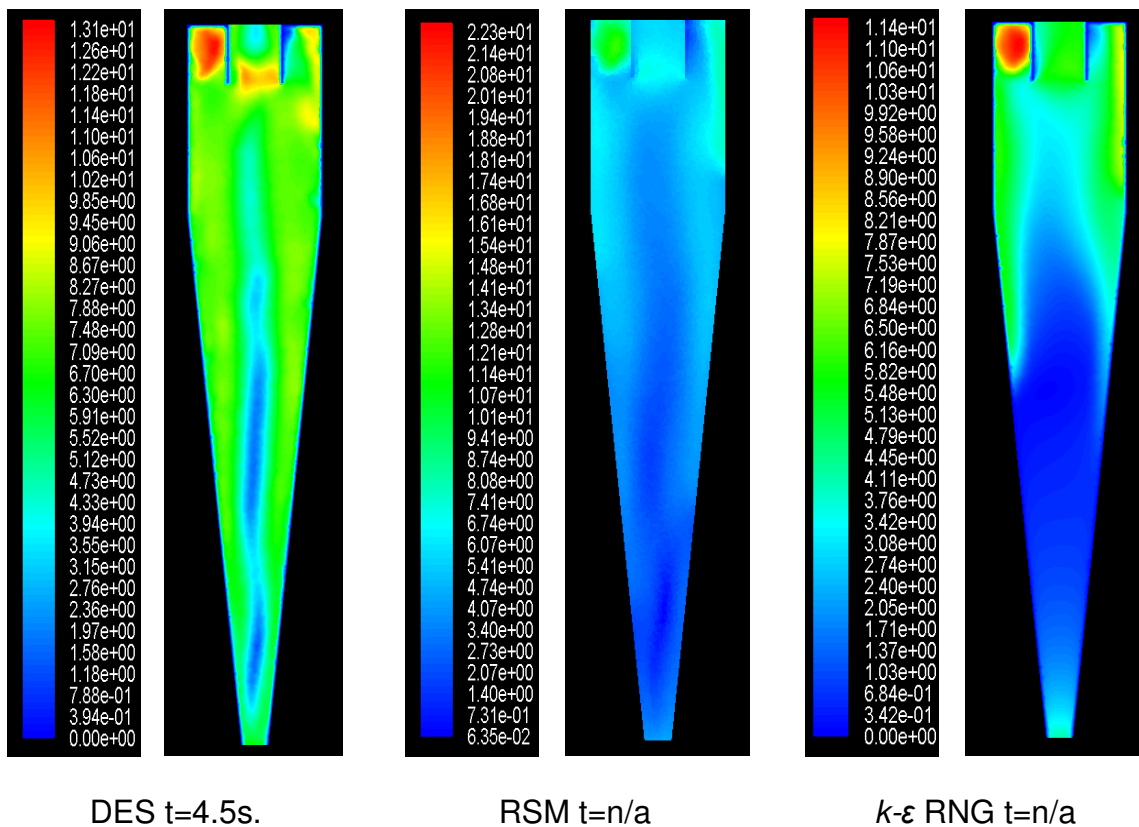

Figure 8. Contours of velocity magnitude for 10m/s Inlet with an 80/20 ratio for overflow/underflow outlets.

The ERCOFTAC test case results and the initial flow analysis of the Rietema Hydrocyclone design will be the focus of future work and will play a significant part in establishing CFD as a viable tool for determining the removal/collection efficiencies of suspended particles for ballast water cyclone designs.

8. Summary and Conclusion

Three turbulence models have been applied to analyse the flow within a square profile duct with a 180° bend. The results have been compared to data published by the European Research Community on Flow and Turbulence And Combustion (ERCOFTAC).

The primary aim of the work was to establish the potential use of Computational Fluid Dynamics, and in particular the Detached Eddy Simulation turbulence model for the design of Ships ballast water hydrocyclones. In this aspect the time dependent nature of the DES model was shown to identify secondary flows more accurately than previous $k-\epsilon$ numerical work, furthermore the application of a coarse mesh DES analysis resulted in modelled flow which was similar in nature to the time averaged experimental results of Chang et al.

While the $k-\epsilon$ vs. DES results show that DES catches flow phenomenon more accurately, yet in certain circumstances the Reynolds Stress model may be more effectively used. For the purpose of cyclone analysis however the initial flow analysis of the Rietema design indicates that the DES model would be more suitable.

References

1. McCluskey, D.K., A.E. Holdo, and R. Calay, *A Review of Ballast Water Technologies*. Journal of Marine Design and Operation, 2006. **B(9)**: p. 21 - 29.
2. Matheickal, J. and S. Raaymakers. *2nd International Ballast Water Treatment R&D Symposium, IMO London 21-23 July 2003: Symposium Proceedings*. in *GloBallast Monograph Series No. 15*. 2003: IMO London.
3. Nilsen, B., H. Nilsen, and T. Mackey. *The OptiMar Ballast System*. in *1st Ballast Water Treatment R&D Symposium*. 2003: IMO London.
4. Squires, K.D. *Detached-Eddy Simulation: Current Status and Perspectives*. in *Mechanical and Materials Engineering Symposium and ME 598 Graduate Seminar*. 2005. Arizona State University.
5. FLUENT, *FLUENT 6.3 User's Guide: 12.17 Setting up the Detached Eddy Simulation Model*. Vol. 2. 2006, Lebanon, NH: Fluent Inc.
6. Choi, Y.D., H. Iacovides, and B.E. Launder, *Numerical Computation of Turbulent Flow in a Square Sectioned 180 Deg Bend*. Journal of Fluids Engineering, 1989. **111**: p. 59 - 68.
7. Choi, Y.D., C. Moon, and S.H. Yang. *Measurement of Turbulent Flow Characteristics of Square Duct with a 180 ° Bend by Hot Wire Anemometer*. in *International Symposium on Engineering*. 1990.
8. ERCOFTAC. *European Research Community On Flow, Turbulence And Combustion*. [Available from: <http://www.ercofac.org>.]
9. Rietema, K., *Performance and Design of Hydrocyclones--I : General Considerations*. Chemical Engineering Science, 1961. **15(3-4)**: p. 298-302.
10. Rietema, K., *Performance and Design of Hydrocyclones--II : Pressure Drop in the Hydrocyclone*. Chemical Engineering Science, 1961. **15(3-4)**: p. 303-309.
11. Rietema, K., *Performance and Design of Hydrocyclones--III : Separating Power of the Hydrocyclone*. Chemical Engineering Science, 1961. **15(3-4)**: p. 310-319.
12. Rietema, K., *Performance and Design of Hydrocyclones--IV : Design of Hydrocyclones*. Chemical Engineering Science, 1961. **15(3-4)**: p. 320-325.