

19



Europäisches Patentamt
European Patent Office
Office européen des brevets



11 Publication number:

0 316 171 B1

12

EUROPEAN PATENT SPECIFICATION

45 Date of publication of patent specification: **30.09.92** 51 Int. Cl.⁵: **G01N 15/02**

21 Application number: **88310595.9**

22 Date of filing: **10.11.88**

Consolidated with 88909594.9/0389512
(European application No./publication No.) by
decision dated 06.03.91.

54 **Particle asymmetry analyser.**

30 Priority: **10.11.87 GB 8726304**

43 Date of publication of application:
17.05.89 Bulletin 89/20

45 Publication of the grant of the patent:
30.09.92 Bulletin 92/40

84 Designated Contracting States:
AT BE CH DE ES FR GB GR IT LI LU NL SE

56 References cited:
GB-A- 2 041 516
US-A- 4 606 636

K.R. SPURNY: "Physical and chemical characterization of individual airborne particles", 1986, pages 101-115, Ellis Horwood Ltd, GB;
J. ALLEN: "Size and shape measurement of individual aerosol particles by asymmetric laser light scattering"

73 Proprietor: **The Secretary of State for Defence in Her Britannic Majesty's Government of the United Kingdom of Great Britain and Northern Ireland Whitehall London SW1A 2HB(GB)**

72 Inventor: **Ludlow, Ian Keith Parkway Close Welwyn Garden City Hertfordshire(GB)**
Inventor: **Kaye, Paul Henry 1, Coopers Close Kimpton Hertfordshire(GB)**

74 Representative: **Beckham, Robert William et al Procurement Executive Ministry of Defence Patents 1A(4), Room 2014 Empress State Building Lillie Road London SW6 1TR(GB)**

EP 0 316 171 B1

Note: Within nine months from the publication of the mention of the grant of the European patent, any person may give notice to the European Patent Office of opposition to the European patent granted. Notice of opposition shall be filed in a written reasoned statement. It shall not be deemed to have been filed until the opposition fee has been paid (Art. 99(1) European patent convention).

Description

This invention relates to the techniques for the analysis of fluid-borne particles and particularly for looking at the asymmetry of such particles. For example, in the study of aerosols, aerosol dispersions and airborne particulate pollution control, there is a requirement for the rapid determination of particle size distribution especially in the diameter range 1 to 10 microns, together with some knowledge of the geometry and symmetry of individual particles. The latter information could, for example, enable particles with spherical symmetry to be identified and thus allow the counting/monitoring of liquid droplets in an environment including other solid, non-spherical particles. In the context of the present specification, the term particles is intended to apply both to solid bodies and to drops of liquid.

It is desirable for such techniques to be able to count individual particles in a sample at rates of, typically, 20,000 particles per second, to be able to distinguish between spherical and non-spherical particles in the sample and to count each type. Another desirable feature is to categorise spherical particles having diameters of 0.5 - 15 microns into a number of size bands and also in this connection to classify particle coincidences as 'non-spherical' and hence to ignore them in the compilation of size spectra.

The normal techniques for the examination of particles, as used in several instruments available commercially, employ the detection and analysis of electromagnetic radiation scattered by the particles. All such instruments use a mechanical mechanism to drive the sample air through a "sensing volume" where the carried particles are illuminated by the incident electromagnetic radiation. The radiation scattered by the particles is received by one or more detectors which convert the energy to electrical signals from which information may be extracted by appropriate electrical circuits.

One class of instrument available commercially permits the collection of scattered radiation from large numbers of particles simultaneously, and uses this information to determine a mean figure for particulate mass per unit volume of gas or air, or the statistically averaged size distribution of particulate matter. These instruments are not capable of examining individual particles, and therefore cannot yield accurate particle counts or information relating to particle morphology.

A second class of instrument uses the properties of laminar flow in gases to restrict the particles to a smaller sensing volume and then, by focusing the incident electromagnetic radiation in some way, is capable of the examination of individ-

ual particles, yielding a particle count and possibly approximate size distribution.

These prior art instruments, therefore, will give, to a certain extent, information on particle size and particle count.

A third class of instrument includes means for providing a sample of airborne particulates in the form of a laminar flow, means for illuminating the sample with a laser beam, means for directing the radiation scattered by individual particles in at least one predetermined forward direction and at least three predetermined rearward directions, towards respective scattering collectors; means associated with each collector for detecting the radiation collected thereby; means for deriving data from the detectors to describe the particle and means for comparing the data with data on known shapes to determine the degree of particle symmetry.

In a known form exemplified in Patent Specification GB2041516, the collectors take the form of a prismatic or 'fresnel' lens which deflects parallel light falling on different portions of its surface in different directions, where it is detected by different detectors arranged around it. The amount of light falling on each detector will depend on the way in which light is scattered by the particles and distributed by the lens.

According to the present invention an analyser of the kind described above is provided in which the configuration of the radiation collectors can be varied at will to allow collection of radiation scattered at different angles.

The scattered radiation is reflected by a concave reflector, preferably an ellipsoid mirror which directs the radiation towards radiation collectors. Radiation scattered at low angles is collected in a second chamber, which leads from an aperture in the ellipsoid mirror, by radiation collectors, preferably optical fibres arranged concentrically around the unscattered beam. The radiation collected is then detected by conversion into electrical signals, for processing and analysis. By comparing with data on known particles shapes the particles are ascribed an asymmetry factor.

Furthermore, in addition to the asymmetry factor the size of the particle may also be determined. A large number of particles may be ascribed an asymmetry factor, and the cumulative results of this operation coupled with the associated size spectra, could be used to generate a topographical 'thumb print' of the particles in an environment which may be of more value than the data of single particles taken alone.

The criterion of classification for spherical particles can be defined readily as symmetrical scattering about the axis of the illuminating beam of radiation, providing that it is randomly polarised or circularly polarised. Therefore in looking for spher-

ricity a number of radiation collectors are placed radially symmetrically about the reflection axis of the concave reflector.

However, if looking for the degree of asymmetry, this arrangement of the collectors could not be assumed to be the optimum for particle asymmetry analysis. The design of the scatter chamber must therefore allow for flexibility of collector configurations, by allowing the positions of the collectors to be varied at will. This is most easily achieved by using optical fibre collection optics.

The advantage of using optical fibres is that one can readily simulate the effect of placing almost any number of collectors at any position around most of the scattering sphere, a task which would otherwise be mechanically extremely difficult. Thus with a high degree of flexibility, various detection geometries may be tested without the need for mechanical changes to the chamber itself.

According to a second aspect of the present invention a method of determining the asymmetry of particles including the steps of:-

providing a sample of airborne particulates in the form of a laminar flow; illuminating the sample with a laser beam, reflecting the radiation scattered by individual particles to at least one forward scattering collector and at least three rearward scattering collectors; detecting the radiation collected by each collector; deriving from the detected radiation data describing the particle; and comparing the data with data on known shapes to determine the degree of particle symmetry, is characterised in that the configuration of the radiation collectors can be varied at will to allow collection of radiation scattered at different angles.

The sample may be an aerosol.

Two embodiments of the invention will now be described by way of example only and with reference to the accompany drawings of which:

Figure 1 is a schematic side view in section of a particle asymmetry analyser, arranged for analysing spherical particles.

Figure 2 is a sectional view of the analyser in Figure 1 along the line x-x.

Figure 3 is a schematic side view in section of another asymmetry analysis system.

Figure 1 illustrates a form of the invention in which a parabolic concave reflector (1) is located at one end of a scatter chamber (2). Mounted at the other end of the scatter chamber (2) and aligned with the principal axis of the reflector (1) is a laser (3), which directs a beam of radiation (4) towards a hole (5) in the reflector (1) and chamber (2) at the principal axis of the reflector. After passing through the hole (5) the beam (4) enters a beam dump (6), typically a Rayleigh horn.

A sample (7) of fluid is delivered in laminar flow, by means of a sheath air intake (12) sup-

plying a layer of air at a constant velocity.

Figure 1 illustrates how in use the sample (7) is supplied in laminar flow by means of a sheath of constant velocity filtered air being supplied around the sample. Thus the outer parts of the sample flow at the same velocity as the inner parts. The outer parts of the sample would otherwise flow more slowly due to friction with the stationary air next to the sample flow. Additionally, and more importantly the coaxial tube supplying the sheath of air is designed to dynamically focus the particles in the sample of provide a laminar flow of particles, thus making it easier to line up the particle flow on the focal point of the reflector.

The sample (7) of laminar flow air is directed into the chamber (2) to intercept at right angles the laser beam (4) at the focal point of the parabolic reflector (1).

A particle in the sample (7) will deflect the radiation out of the beam (4) onto the reflector (1) which reflects it parallel to the principal axis to radiation collectors (8) adjacent the laser (3). The radiation collectors (8) may be optical fibres, lenses (as shown) or a combination of both for directing the light onto such detectors.

As shown in Fig 2 three radiation collectors 8 can be arranged radially around the beam 4. When the collectors are arranged in this manner symmetrical scattering can be detected which will identify spherical particles. Indeed, any number of radiation collectors 8 may be arranged radially about the beam of radiation 4.

A certain amount of difficulty is experienced in capturing and analysing the radiation scattered at low angles to the beam (4) direction. At very low angles (1° to 3°) they are swamped by light scattering from laser focussing optics. To overcome this a second scattering chamber (13) is introduced coaxial to the principal axis of the concave reflector (1) on the main scatter chamber (2). Radiation collectors (8) are suitably placed in this chamber to collect the low angle deflections.

As illustrated in Figure 1, the second chamber (13) may have a second concave reflector (16), which would normally be ellipsoidal, having the point of intersection of the beam (4) and the sample (7) as its second or distal focal point and having a radiation collector (15) at its first or proximal focal point. Thus radiation deflected at low angles will strike the ellipsoidal reflector and be directed into the radiation collector (15), where it is focussed onto detector (21).

The radiation collector (15) may be positioned to face the aperture (5) on the first chamber or may be positioned at 90° to this direction as shown in Figure 1. The latter arrangement would collect relatively more radiation of low angle of deflection, but less overall since only deflections in the direction

of the face of the collector will be recorded.

Figure 3 shows a preferred embodiment of a particle analyser according to the present invention. In this embodiment, the laser (3) is mounted beneath the chamber (2) and at 90° to principal axis of the reflector (1), the beam (4) being reflected onto the principal axis of the reflector by a prism or mirror (9) suitably positioned on the axis. Indeed, the laser (3) may be mounted almost anywhere about the scatter chamber (2) with an appropriately angled mirror (9) on the axis.

The sample (7) of laminar flow air is directed into the chamber in the same manner as described above.

Figure 3 also illustrates the scatter chamber (2) having an ellipsoid reflector (10) with the point of intersection between the beam (4) and the sample (7) being one focal point of the ellipse and a collector lens (11) mounted near the second focal point to render parallel the reflected radiation to optical fibres (8) at the end of the chamber (2). At this point the intensity distribution represents a spatially modified replica of that scattered into approximately 0.84 of a sphere by the particle.

To collect radiation scattered at low angles, figure 3 illustrates a second chamber (13) in which optical fibres (14) are arranged around the beam (4). The optical fibres (14) may be arranged in concentric rings around the beam (4). The fibres (14) collect radiation and direct it to detectors (21) for converting the radiation collected into electrical signals for processing and analysis.

The asymmetry particle analyser operates as follows. The laser beam, produced by a gas laser, enters the chamber at right angles to the reflector axis and it reflected through 90° along the principal axis of the reflector. The radiation scattered by individual particles from approximately 19° to 145° relative to the beam axis is thus reflected onto the aspheric collection lens at the rear of the chamber. This lens renders the emerging light parallel, and the intensity distribution across this output window represents a spatially modified replica of that scattered into approximately 0.84 of a sphere by the particle.

With the collected light in the form described above, the positions of the optical fibre collectors to measure the light distribution may be varied at will.

To determine particle sphericity the collectors would be placed symmetrically about the axis of the output window, in a similar manner to the arrangement in Figure 1.

In this way, with the use of optical fibre optics, one can readily simulate the effect of placing almost any number of detectors at any position around most of the whole scattering sphere.

Based upon the results of theoretical models and experimental results of scattering patterns of

known shapes, algorithms are used to ascribe to particles an asymmetry factor.

The processing of data from particles to determine their asymmetry could be handled by transputers as produced for example by the British Inmos chip manufacturers.

One transputer can be used for each detection channel. In this way, tasks hitherto performed serially on incoming data from channels could be preformed on all channels simultaneously giving a substantial increase in data throughput.

Although this invention has been described by way of example and with reference to possible embodiments thereof, it is to be understood that modifications or improvements may be made without departing from the scope of the invention as defined in the appended claims.

Claims

1. A particle analyser for use in determining the degree of symmetry of particles, having means for providing a sample of airborne particulates in the form of a laminar flow, means for illuminating the sample with a laser beam, means for directing radiation scattered by individual particles in at least three predetermined rearward directions and one predetermined forward direction towards respective radiation collectors, means associated with each collector for detecting the radiation collected thereby, means for deriving data from the detectors to describe the particles, and means for comparing the data with data from particles of known shapes to determine the degree of individual particle symmetry; characterised in that the configuration of the radiation collectors can be varied at will to allow collection of radiation scattered at different predetermined angles.
2. A particle analyser as claimed in Claim 1, wherein the laser beam is randomly or circularly polarised.
3. A particle analyser as claimed in Claim 1 or 2, characterised in that in one configuration the radiation collectors can be placed radially symmetrically about an axis defined by the laser beam.
4. A particle analyser as claimed in any preceding Claim characterised in that the means of directing the radiation is a concave reflector.
5. A particle analyser as claimed in Claim 4 characterised in that the concave reflector is an ellipsoid reflector.

6. A particle analyser as claimed in Claim 4 or 5 when dependent on Claim 3 characterised in that the central axis is the reflection axis of the concave reflector. 5
7. A particle analyser as claimed in any preceding Claim characterised in that the detectors are photomultipliers. 10
8. A particle analyser as claimed in any preceding Claim characterised in that the collectors are optical fibres. 15
9. A method of determining the degree of symmetry of particles including the steps of providing a sample of airborne particulates in the form of a laminar flow; illuminating the sample with a laser beam, reflecting the radiation scattered by individual particles to at least one forward scattering collector and at least three rearward scattering collectors, detecting the radiation collected by each collector; deriving from the detected radiation data describing the particle; and comparing the data with data on known shapes to determine the degree of particle symmetry characterised in that the configuration of the radiation collectors can be varied at will to allow collection of radiation scattered at different angles. 20 25 30
10. A method as claimed in Claim 9 characterised in that the laser beam is randomly or circularly polarised. 35
11. A method as claimed in Claim 9 or 10 characterised in that the radiation scattered by individual particles is reflected by a concave reflector towards the light collectors. 40
12. A method as claimed in Claim 11 characterised in that the concave reflector has an ellipsoid interior surface. 45
13. A method as claimed in Claim 11 or 12 wherein the rearward scattering detectors are placed radially symmetrically about the reflection axis of the reflector. 50
14. A method as claimed in any of Claims 9 to 13 characterised in that the detectors are photomultipliers. 55
15. A method as claimed in any of Claims 9 to 14 characterised in that the collectors are optical fibres.

Patentansprüche

1. Teilchenanalysator zum Gebrauch bei der Bestimmung des Symmetriegrads von Teilchen, wobei der Teilchenanalysator aufweist: eine Einrichtung zum Bereitstellen einer Probe von freischwebenden Teilchen in Form einer Laminarströmung, eine Einrichtung zum Bestrahlen der Probe mit einem Laserstrahl, eine Einrichtung zum Richten von von einzelnen Teilchen gestreuter Strahlung in wenigstens drei vorbestimmten Rückwärtsrichtungen und einer vorbestimmten Vorwärtsrichtung auf jeweilige Strahlungskollektoren, jedem Kollektor zugeordnete Einrichtungen zum Detektieren der von diesem gesammelten Strahlung, eine Einrichtung zum Ableiten von Daten aus den Detektoren, um die Teilchen zu beschreiben, und eine Einrichtung zum Vergleichen der Daten mit Daten von Teilchen bekannter Gestalten, um den Symmetriegrad einzelner Teilchen zu bestimmen; dadurch gekennzeichnet, daß die Konfiguration der Strahlungskollektoren beliebig änderbar ist, um das Sammeln von unter verschiedenen vorbestimmten Winkeln gestreuter Strahlung zuzulassen.
2. Teilchenanalysator nach Anspruch 1, wobei der Laserstrahl willkürlich oder kreisförmig polarisiert ist.
3. Teilchenanalysator nach Anspruch 1 oder 2, dadurch gekennzeichnet, daß bei einer Konfiguration die Strahlungskollektoren radial symmetrisch um eine von dem Laserstrahl definierte Achse herum angeordnet sein können.
4. Teilchenanalysator nach einem der vorhergehenden Ansprüche, dadurch gekennzeichnet, daß die Einrichtung zum Richten der Strahlung ein Konkavreflektor ist.
5. Teilchenanalysator nach Anspruch 4, dadurch gekennzeichnet, daß der Konkavreflektor ein Ellipsoidreflektor ist.
6. Teilchenanalysator nach Anspruch 4 oder 5, wenn diese sich auf Anspruch 3 beziehen, dadurch gekennzeichnet, daß die Mittelachse die Reflexionsachse des Konkavreflektors ist.
7. Teilchenanalysator nach einem der vorhergehenden Ansprüche, dadurch gekennzeichnet, daß die Detektoren Fotovervielfacher sind.
8. Teilchenanalysator nach einem der vorhergehenden Ansprüche, dadurch gekennzeichnet,

daß die Kollektoren Lichtwellenleiter sind.

9. Verfahren zum Bestimmen des Symmetriegrads von Teilchen, das folgende Schritte aufweist: 5
 Bereitstellen einer Probe von freischwebenden Teilchen in Form einer Laminarströmung;
 Bestrahlen der Probe mit einem Laserstrahl, Reflektieren der von einzelnen Teilchen gestreuten Strahlung auf wenigstens einen vorderen Streustrahlungskollektor und wenigstens drei hintere Streustrahlungskollektoren, Detektieren der von jedem Kollektor gesammelten Strahlung; 10
 Ableiten von Daten, die die Teilchen beschreiben, aus der detektieren Strahlung; 15
 und Vergleichen der Daten mit Daten über bekannte Gestalten, um den Symmetriegrad von Teilchen zu bestimmen, dadurch gekennzeichnet, daß die Konfiguration der Strahlungskollektoren beliebig änderbar ist, um das Sammeln von unter verschiedenen Winkeln gestreuter Strahlung zuzulassen. 20
10. Verfahren nach Anspruch 9, dadurch gekennzeichnet, daß der Laserstrahl willkürlich oder kreisförmig polarisiert wird. 25
11. Verfahren nach Anspruch 9 oder 10, dadurch gekennzeichnet, daß die von einzelnen Teilchen gestreute Strahlung von einem Konkavreflektor auf die Lichtkollektoren reflektiert wird. 30
12. Verfahren nach Anspruch 11, dadurch gekennzeichnet, daß der Konkavreflektor eine ellipsoide Innenfläche hat. 35
13. Verfahren nach Anspruch 11 oder 12, wobei die hinteren Streustrahlungsdetektoren radial symmetrisch um die Reflexionsachse des Reflektors herum angeordnet sind. 40
14. Verfahren nach einem der Ansprüche 9 bis 13, dadurch gekennzeichnet, daß die Detektoren Fotovervielfacher sind. 45
15. Verfahren nach einem der Ansprüche 9 bis 14, dadurch gekennzeichnet, daß die Kollektoren Lichtwellenleiter sind. 50

Revendications

1. Analyseur de particules destiné à être utilisé pour la détermination du degré de symétrie des particules, comprenant un dispositif destiné à former un échantillon de particules en suspension dans l'air sous forme d'un courant laminaire, un dispositif d'éclairement de 55

l'échantillon par un faisceau laser, un dispositif destiné à diriger le rayonnement diffusé par les particules individuelles dans au moins trois directions prédéterminées vers l'arrière et une direction prédéterminée vers l'avant, vers des collecteurs respectifs de rayonnement, un dispositif associé à chaque collecteur et destiné à détecter le rayonnement collecté par celui-ci, un dispositif destiné à dériver les données des détecteurs afin que les particules soient décrites, et un dispositif destiné à comparer les données à des données de particules de configuration connue afin que le degré de symétrie des particules individuelles soit déterminé,

caractérisé en ce que la configuration des collecteurs de rayonnement peut être modifiée à volonté afin que le rayonnement diffusé puisse être collecté pour différents angles prédéterminés.

2. Analyseur de particules selon la revendication 1, dans lequel le faisceau laser est polarisé aléatoirement ou circulairement.
3. Analyseur de particules selon la revendication 1 ou 2, caractérisé en ce que, dans une configuration, les collecteurs de rayonnement peuvent être placés avec une symétrie radiale autour d'un axe délimité par le faisceau laser.
4. Analyseur de particules selon l'une quelconque des revendications précédentes, caractérisé en ce que le dispositif destiné à diriger le rayonnement est un réflecteur concave.
5. Analyseur de particules selon la revendication 4, caractérisé en ce que le réflecteur concave est un réflecteur ellipsoïdal.
6. Analyseur de particules selon la revendication 4 ou 5 lorsqu'elle dépend de la revendication 3, caractérisé en ce que l'axe central est l'axe de réflexion du réflecteur concave.
7. Analyseur de particules selon l'une quelconque des revendications précédentes, caractérisé en ce que les détecteurs sont des photomultiplicateurs.
8. Analyseur de particules selon l'une quelconque des revendications précédentes, caractérisé en ce que les collecteurs sont des fibres optiques.
9. Procédé de détermination du degré de symétrie de particules, comprenant les étapes suivantes :
 la formation d'un échantillon de particules en suspension dans l'air sous forme d'un cou-

rant laminaire,

l'éclairement de l'échantillon par un faisceau laser, avec réflexion du rayonnement diffusé par les particules individuelles vers au moins un collecteur de diffusion vers l'avant et au moins trois collecteurs de diffusion vers l'arrière, avec détection du rayonnement collecté par chaque collecteur,

5

la dérivation, à partir du rayonnement détecté, de données décrivant la particule, et

10

la comparaison des données à des données relatives à des formes connues afin que le degré de symétrie de la particule soit déterminé, caractérisé en ce que la configuration des collecteurs de rayonnement peut être modifiée à volonté afin que le rayonnement diffusé à des angles différents puisse être collecté.

15

- 10.** Procédé selon la revendication 9, caractérisé en ce que le faisceau laser est polarisé aléatoirement ou circulairement. 20
- 11.** Procédé selon la revendication 9 ou 10, caractérisé en ce que le rayonnement diffusé par les particules individuelles est réfléchi par le réflecteur concave vers les collecteurs de lumière. 25
- 12.** Procédé selon la revendication 11, caractérisé en ce que réflecteur concave a une surface interne ellipsoïdale. 30
- 13.** Procédé selon la revendication 11 ou 12, dans lequel les détecteurs de diffusion vers l'arrière sont placés radialement de manière symétrique autour de l'axe de réflexion du réflecteur. 35
- 14.** Procédé selon l'une quelconque des revendications 9 à 13, caractérisé en ce que les détecteurs sont des photomultiplicateurs. 40
- 15.** Procédé selon l'une quelconque des revendications 9 à 14, caractérisé en ce que les collecteurs sont des fibres optiques. 45

45

50

55

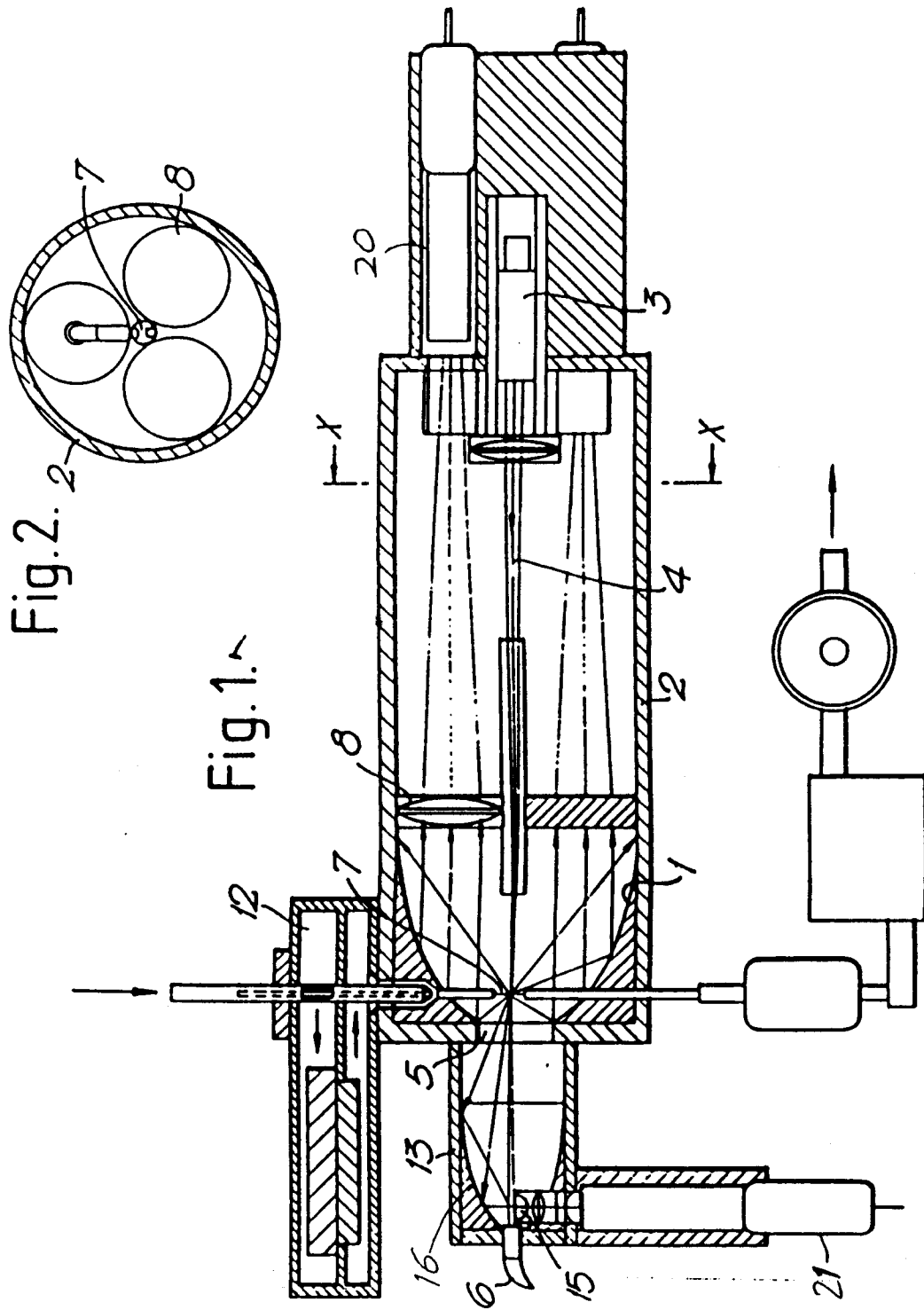

Fig.3.

